

FPS

Professional Water Systems Equipment



Franklin Electric

Model Number Nomenclature.....	2	SWJ Series	82
Submersible Pumps:		Convertible Jet Pumps	
4" 3200 Series Pumps		Convertible VersaJet Pro Series.....	84
Features & Ordering Information	4	Convertible VersaJet Series	88
5 gpm	5	Pro Series	92
7 gpm	7	Jet Pump Accessories	
Dimensions.....	9	Accessories.....	96
4" Tri-Seal Pumps		AQ80.....	98
Features & Ordering Information	10	Air Charger Kit.....	99
5 gpm	11	Self-Priming Centrifugal Pumps	
7 gpm	13	Turf Boss	100
10 gpm.....	15	End Suction Centrifugal Pumps	
15 gpm.....	17	DDS Series.....	103
20 gpm	19	Close Coupled Centrifugal Pumps	
25 gpm	21	FCE Series	106
Dimensions.....	23	Non-Corrosive Centrifugal Pumps	
4" Series V Pumps		A Series.....	108
Features & Ordering Information	25	S Series.....	110
5 gpm	26	JCM Series.....	112
7 gpm	28	Horizontal Multi-Stage Centrifugal Pumps	
10 gpm.....	30	MH Series.....	114
15 gpm.....	32	Booster Pumps	
20 gpm	34	BT4 Series.....	119
25 gpm	36	Constant Pressure Systems	
Dimensions.....	38	SubDrive Inline 1100.....	129
4" High Capacity Pumps		Submersible Motors, Drives,	
Features & Ordering Information	40	Controls & Protection:	
35 gpm	42	Submersible Motors	
45 gpm	44	4" Submersible Motors	132
60 gpm	46	Protection	
90 gpm	48	Pumptec Family	143
6" High Capacity Pumps		Drives	
Features & Ordering Information	50	Features & Ordering Information	145
50 gpm	52	SubDrive75.....	150
75 gpm	54	SubDrive100.....	154
100 gpm.....	56	SubDrive150.....	157
125 gpm.....	58	SubDrive300.....	162
E-Series Environmental Pumps		Accessories	166
Features	60	References:	
Thermoplastic Ordering Information.....	61	Friction Loss	168
10 gpm Thermoplastic	62	Pipe Fittings	171
20 gpm Thermoplastic.....	64	Pressure Loss	172
Stainless Steel Ordering Information.....	61	Pressure Tank Sizing	174
35 gpm Stainless Steel.....	66	Reference Tables	175
45 gpm Stainless Steel.....	68	Conversions.....	176
60 gpm Stainless Steel.....	70	2- or 3-Wire Cable, 60Hz	177
90 gpm Stainless Steel.....	72	Warranty Information:	
C1 Series Cistern Pumps		Lost or Damaged Goods	178
Features & Ordering Information	74	Limited Warranty.....	179
Submersible Pump Accessories			
Ordering Information.....	76		
Non-Submersible Pumps:			
Jet Pumps			
Shallow Well Jet Pumps			
VersaJet Pro.....	77		
VersaJet	79		

Model Number Nomenclature

Pump & Motor Brand/Series Codes:

FA = FPS 4400
FV = FPS Series V
FE = FPS Environmental
FP = FPS Brand

Centrifugal Pump Series Codes:

F = FPS
VJ = VersaJet (Shallow Well)
P = Pro Series (Convertible)
CVJ = Convertible VersaJet (Convertible)
SWJ = Shallow Well Jet
TB = Turf Boss (Sprinkler)
MH = Multistage Horizontal (Stainless Booster)
BT = BT4 (Horizontal Booster)

Horsepower Codes:

HP	1/3	1/2	3/4	1	1.5	2	3	5	7.5	10	15	20
Code	03	05	07	1	15	2	3	5	7	10	15	20
HP	25	30	35	40	50	60	75	100	125	150	175	200
Code	25	30	35	40	50	60	75	100	125	150	175	200

Material Codes:

CI = Cast Iron
P = Plastic
S = Stainless Steel

Model Number Nomenclature

4" 5-25 GPM Submersible Pumps/Motors:

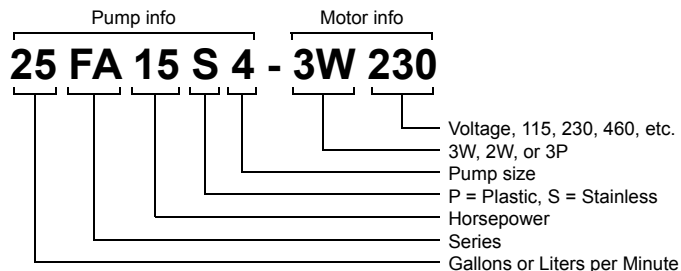

Examples:

15FA1S4-2W115 = 15 gpm, FPS 4400 Tri-Seal, Stainless Steel, 1 hp, 115 V, 2-wire Motor
10FA15SA-3W230 = 10 gpm, FPS 4400 Tri-Seal, Stainless Steel, 1.5 hp, 230 V, 3-wire Motor

Pump End:

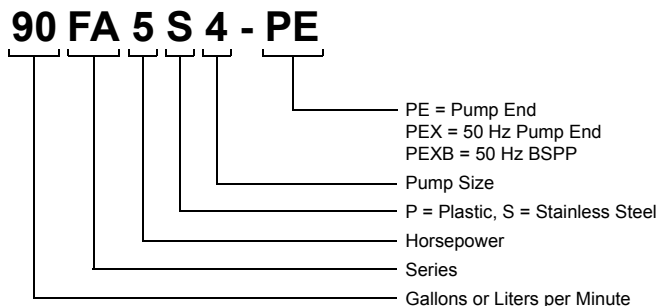

Examples:

45FA3S4-PE = 45 gpm, FPS 4400, 3 hp, Stainless Steel, Pump End
25FE1P4-PEXB = 25 lpm, FPS E Series, 1 hp, Plastic, 50 Hz Pump End BSPP Threads

Centrifugal Pumps:

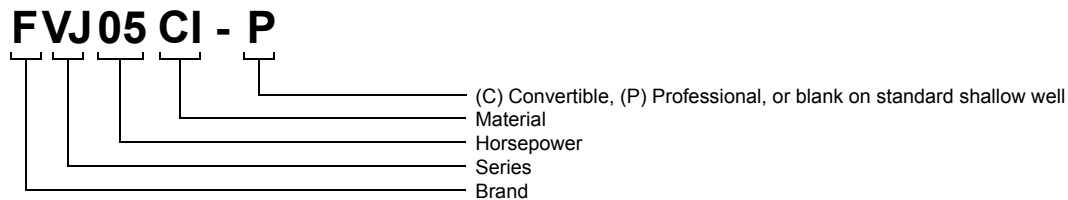

Examples:

FVJ07CI-P = FPS Brand, VersaJet, 3/4 hp, Cast Iron, Professional
FTB2CI = FPS Brand, Turf Boss, 2 hp, Cast Iron
FP1CI-C = FPS Brand, Pro Series, 1 hp, Cast Iron, Convertible

Submersible Pumps

4" 3200 Series Pumps - Features



FPS 3200 series

4" Reduced Diameter Submersible Pumps

The 3200 Series submersible pumps are designed so that all parts of the pump end, including the cable guard, fall within the diameter of Franklin Electric's industry leading submersible 4" motor. This reduced diameter pump end makes it ideal for installations where the well is considered encrusted or tight in comparison to a standard 4" well. The 3200 Series also offers a hydraulic stage design optimized for greater water and pressure output when installed at deeper well depths. For details on how to become a registered dealer and receive a 5-year warranty, contact your local distributor.

Features:

- Pump diameter is smaller than a standard 4" submersible for easier installation in reduced diameter 4" wells.
- Hex rubber bearing and ceramic shaft sleeve allows sand and abrasives to pass through, virtually eliminating shaft wear and upper bearing failures.
- Improved hydraulic performance for deeper set depths at all horsepower and flow ratings.
 - Floating stage design allows for maximum efficiency while minimizing the downthrust load that is transferred to the motor.
 - Noryl[®] diffuser and disc with 300 Series stainless steel thrust and eye seal protection for durability and abrasion resistance.
 - Celcon[®] impeller provides high performance to increase pressure output while reducing system losses from friction.
- Removable spring-loaded check valve.
- Stainless steel pump intake screen and stainless steel cable guard.
- Maximum water temperature: 120 °F / 49 °C.
- Powered by corrosion-resistant Franklin Electric submersible 4" motor with lightning protection.

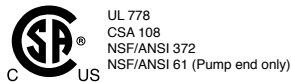

Celcon[®] is a registered trademark of the Celanese Corporation.
Noryl[®] is a registered trademark of G.E.

Submersible Pumps

4" 3200 Series - 5 GPM

Plastic Ordering Information

GPM	HP	Stg.	Volts	2-Wire		3-Wire		
				Model No.	Order No.	Model No.	Order No.	Control Box
5	1/2	13	115	5FR05P4-2W115	96210505	5FR05P4-3W115	96210530	2801044915
	1/2	13	230	5FR05P4-2W230	96210510	5FR05P4-3W230	96210535	2801054915
	3/4	18	230	5FR07P4-2W230	96210515	5FR07P4-3W230	96210540	2801074915
	1	22	230	5FR1P4-2W230	96210520	5FR1P4-3W230	96210545	2801084915
	1.5	30	230	5FR15P4-2W230	96210525	5FR15P4-3W230	96210550	2823008610

Stainless Steel Ordering Information

GPM	HP	Stg.	Volts	2-Wire		3-Wire		
				Model No.	Order No.	Model No.	Order No.	Control Box
5	1/2	13	115	5FR05S4-2W115	96310505	5FR05S4-3W115	96310530	2801044915
	1/2	13	230	5FR05S4-2W230	96310510	5FR05S4-3W230	96310535	2801054915
	3/4	18	230	5FR07S4-2W230	96310515	5FR07S4-3W230	96310540	2801074915
	1	22	230	5FR1S4-2W230	96310520	5FR1S4-3W230	96310545	2801084915
	1.5	30	230	5FR15S4-2W230	96310525	5FR15S4-3W230	96310550	2823008610

Pump End Assemblies Only Ordering Information

Plastic				
GPM	HP	Stg.	Model No.	Order No.
5	1/2	13	5FR05P4-PE	96220500
	3/4	18	5FR07P4-PE	96220501
	1	22	5FR1P4-PE	96220502
	1.5	30	5FR15P4-PE	96220503

Stainless Steel				
GPM	HP	Stg.	Model No.	Order No.
5	1/2	13	5FR05S4-PE	96320500
	3/4	18	5FR07S4-PE	96320501
	1	22	5FR1S4-PE	96320502
	1.5	30	5FR15S4-PE	96320503
	2	38	5FR2S4-PE	96320504

Capacities in U.S. Gallons per Minute

HP	PSI	Depth To Pumping Water Level, or Lift, in Feet. Shaded Areas Indicate Most Efficient Performance																					
		20	40	60	80	100	120	140	160	180	200	250	300	350	400	450	500	600	700	800	900	1000	
1/2	0				8	8	8	7	7	7	6	5	4	3									
	20		8	8	8	7	7	7	6	6	6	4	3										
	30	8	8	7	7	7	7	6	6	6	5	4	1										
	40	8	7	7	7	7	6	6	6	5	5	3											
	50	7	7	7	7	6	6	5	5	4	4	2											
	60	7	7	6	6	6	5	5	4	4	3												
	80	6	6	6	5	5	4	4	3	2													
Shut-off PSI		161	152	143	135	126	117	109	100	91	83	61	39	18									
3/4	0					8	8	8	8	7	7	6	6	5	4	2							
	20				8	8	8	7	7	7	6	6	5	4	2								
	30			8	8	8	7	7	7	7	6	5	4	3	1								
	40		8	8	8	7	7	7	7	6	6	5	4	3									
	50	8	8	8	7	7	7	7	7	6	6	5	4	3	2								
	60	8	8	7	7	7	7	6	6	6	5	4	3										
	80	7	7	7	7	6	6	6	5	5	4	3	1										
Shut-off PSI		226	217	209	200	191	183	174	165	157	148	126	105	83	61	39	18						
1	0						8	8	8	8	7	7	6	6	5	5	2						
	20					8	8	8	8	7	7	6	6	5	5	4	1						
	30				8	8	8	8	7	7	7	6	6	5	4	3							
	40			8	8	8	8	7	7	7	7	6	6	5	5	4	3						
	50		8	8	8	8	7	7	7	7	7	6	6	5	4	3	2						
	60	8	8	8	7	7	7	7	7	7	6	6	5	5	4	3	1						
	80	8	7	7	7	7	7	7	6	6	6	5	5	4	3	1							
Shut-off PSI		280	271	263	254	245	237	228	219	211	202	180	159	137	115	94	72	29					

Submersible Pumps

4" 3200 Series - 5 GPM

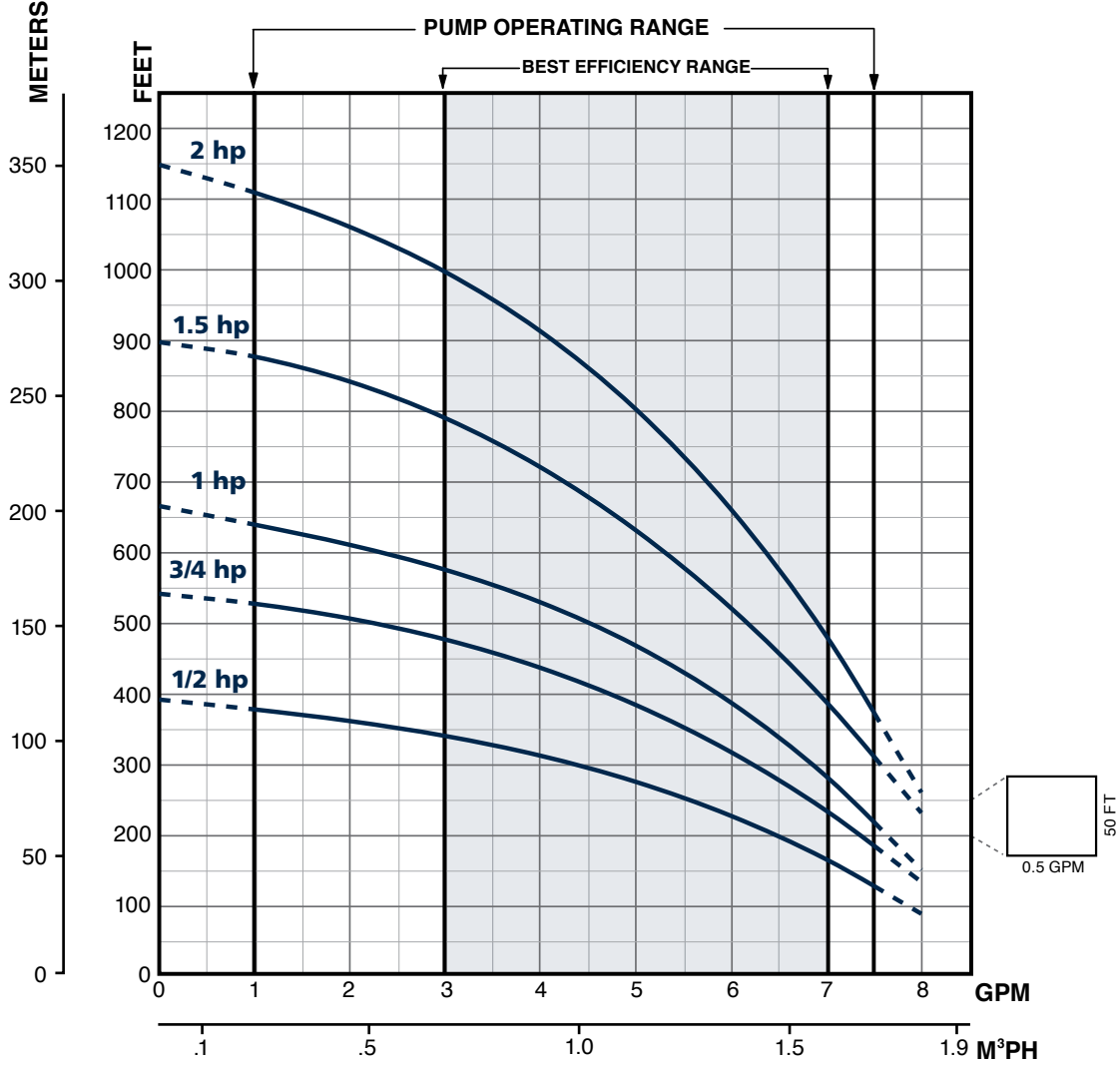

Capacities in U.S. Gallons per Minute

HP	PSI	Depth To Pumping Water Level, or Lift, in Feet. Shaded Areas Indicate Most Efficient Performance																					
		20	40	60	80	100	120	140	160	180	200	250	300	350	400	450	500	600	700	800	900	1000	
1.5	0																						
	20									8	8	8	7	7	7	6	6	5	4	3			
	30								8	8	8	7	7	7	6	6	5	4	3	1			
	40							8	8	8	8	7	7	7	6	6	5	4	3				
	50					8	8	8	8	8	7	7	7	6	6	6	5	4	3				
	60				8	8	8	8	8	8	7	7	7	6	6	5	5	4	2				
	80	8	8	8	8	8	8	7	7	7	7	7	6	6	5	5	4	3	1				
Shut-off PSI		381	372	364	355	346	338	329	320	312	303	281	260	238	216	195	173	130	86	43			
2	0											8	8	8	7	7	7	6	6	5	4	3	
	20										8	8	8	7	7	7	7	6	5	5	4	2	
	30									8	8	8	8	7	7	7	7	6	5	4	3	2	
	40									8	8	8	8	7	7	7	7	6	5	4	3	1	
	50							8	8	8	8	8	7	7	7	7	6	6	5	4	3	1	
	60					8	8	8	8	8	8	7	7	7	7	6	6	5	5	4	2		
	80				8	8	8	8	8	8	7	7	7	7	6	6	5	4	3	2			
Shut-off PSI		491	482	473	465	456	447	439	430	421	413	391	369	348	326	304	282	239	195	152	109	66	

Submersible Pumps

4" 3200 Series - 7 GPM

Plastic	GPM	HP	Stg.	Volts	2-Wire		3-Wire		
					Model No.	Order No.	Model No.	Order No.	Control Box
					7	1/2	10	115	7FR05P4-2W115
	1/2	10	230	7FR05P4-2W230	96210710	7FR05P4-3W230	96210735	2801054915	
	3/4	13	230	7FR07P4-2W230	96210715	7FR07P4-3W230	96210740	2801074915	
	1	18	230	7FR1P4-2W230	96210720	7FR1P4-3W230	96210745	2801084915	
	1.5	23	230	7FR15P4-2W230	96210725	7FR15P4-3W230	96210750	2823008610	

Stainless Steel	GPM	HP	Stg.	Volts	2-Wire		3-Wire		
					Model No.	Order No.	Model No.	Order No.	Control Box
					7	1/2	10	115	7FR05S4-2W115
	1/2	10	230	7FR05S4-2W230	96310710	7FR05S4-3W230	96310735	2801054915	
	3/4	13	230	7FR07S4-2W230	96310715	7FR07S4-3W230	96310740	2801074915	
	1	18	230	7FR1S4-2W230	96310720	7FR1S4-3W230	96310745	2801084915	
	1.5	23	230	7FR15S4-2W230	96310725	7FR15S4-3W230	96310750	2823008610	

Plastic - Pump End Assemblies Only				
GPM	HP	Stg.	Model No.	Order No.
7	1/2	10	7FR05P4-PE	96220700
	3/4	13	7FR07P4-PE	96220701
	1	18	7FR1P4-PE	96220702
	1.5	23	7FR15P4-PE	96220703

Stainless Steel - Pump End Assemblies Only				
GPM	HP	Stg.	Model No.	Order No.
7	1/2	10	7FR05S4-PE	96320700
	3/4	13	7FR07S4-PE	96320701
	1	18	7FR1S4-PE	96320702
	1.5	23	7FR15S4-PE	96320703
	2	30	7FR2S4-PE	96320704
	3	38	7FR3S4-PE	96320705

Capacities in U.S. Gallons per Minute

HP	PSI	Depth To Pumping Water Level, or Lift, in Feet. Shaded Areas Indicate Most Efficient Performance																					
		20	40	60	80	100	120	140	160	180	200	250	300	350	400	450	500	600	700	800	900	1000	
1/2	0				12	12	11	11	10	10	9	7	3										
	20		12	12	11	11	10	9	9	8	7	4											
	30	12	12	11	11	10	9	9	8	7	6	1											
	40	12	11	11	10	9	9	8	7	5	4												
	50	11	10	10	9	8	8	7	5	4	1												
	60	10	10	9	8	7	6	5	3	1													
	80	9	8	7	6	5	3																
Shut-off PSI		132	123	115	106	97	89	80	71	63	54	32	10										
3/4	0				12	12	11	11	10	10	9	8	5	2									
	20				12	11	11	10	10	9	8	6	2										
	30			12	12	11	11	10	10	9	9	7	4										
	40		12	11	11	11	10	10	9	9	8	6	3										
	50	12	11	11	11	10	10	9	8	8	7	5	1										
	60	11	11	10	10	10	9	8	8	7	6	3											
	80	10	10	9	9	8	7	7	6	5	3												
Shut-off PSI		174	165	156	148	139	130	122	113	104	96	74	52	31	9								
1	0						12	12	11	11	10	9	8	7	5								
	20						12	11	11	11	10	9	8	7	5	3							
	30					12	12	11	11	11	10	9	7	6	4	1							
	40					12	11	11	11	10	10	9	8	7	5	3							
	50				12	12	11	11	11	10	10	9	8	6	5	2							
	60		12	12	11	11	11	10	10	10	9	8	7	5	3								
	80	12	11	11	11	10	10	10	9	9	8	7	6	3									
Shut-off PSI		245	237	228	219	211	202	193	185	176	167	146	124	102	81	59	37						

Submersible Pumps

4" 3200 Series - 7 GPM

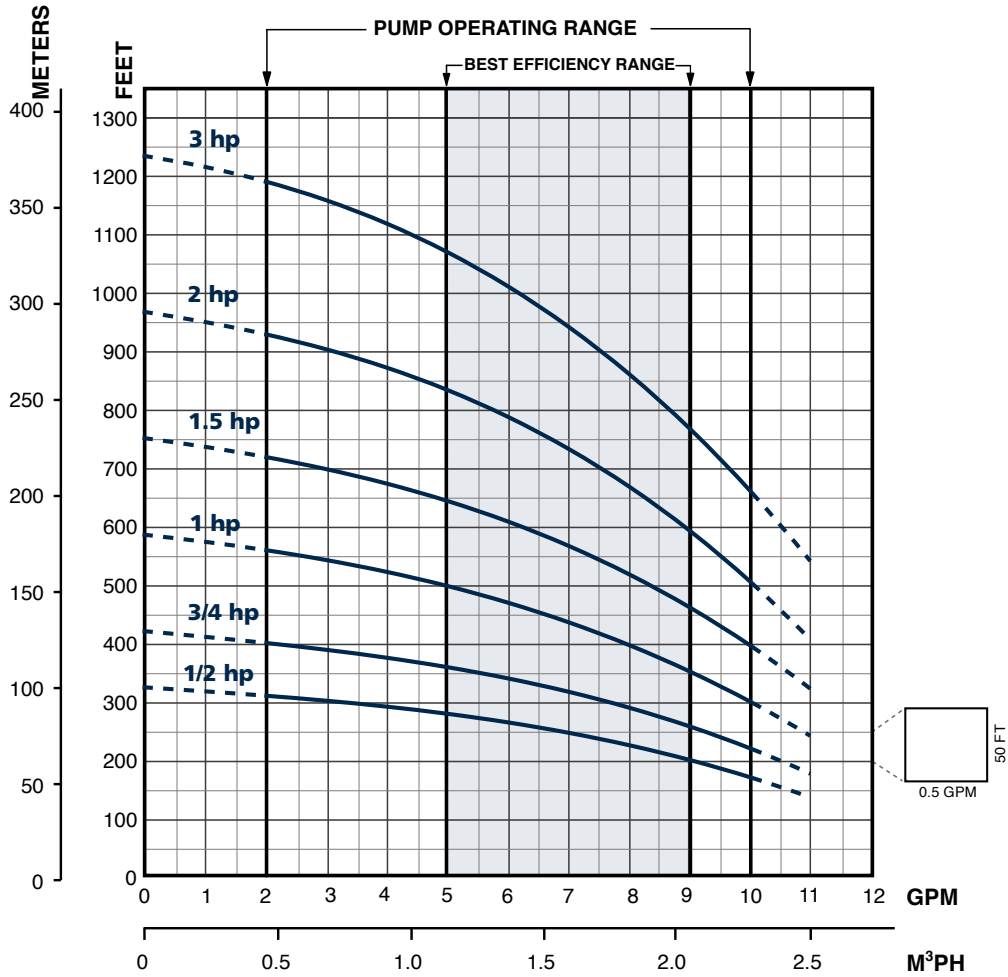

Capacities in U.S. Gallons per Minute

HP	PSI	Depth To Pumping Water Level, or Lift, in Feet. Shaded Areas Indicate Most Efficient Performance																					
		20	40	60	80	100	120	140	160	180	200	250	300	350	400	450	500	600	700	800	900	1000	
1.5	0										12	12	11	11	10	9	8	6	3				
	20									12	12	11	11	10	9	8	7	5					
	30								12	12	12	11	10	10	9	8	7	4					
	40						12	12	12	11	11	10	9	8	8	6	3						
	50					12	12	12	11	11	10	10	9	8	7	6	2						
	60					12	12	11	11	11	10	9	9	8	7	5	1						
	80		12	12	12	11	11	11	11	10	10	9	9	8	7	5	4						
Shut-off PSI		317	309	300	291	283	274	265	257	248	139	218	196	174	153	131	109	66	23				
2	0											12	11	11	11	10	9	8	6	3			
	20										12	12	11	11	10	10	8	7	5	1			
	30										12	12	11	11	10	10	9	8	6	4			
	40								12	12	12	11	11	10	10	9	8	6	3				
	50							12	12	12	11	11	10	10	9	9	7	5	3				
	60						12	12	12	11	11	11	10	10	9	8	7	5	2				
	80					12	12	12	11	11	11	10	10	9	8	8	6	4					
Shut-off PSI		411	403	394	385	376	368	359	350	342	333	312	290	268	247	225	203	160	117	73	30		
3	0				12	11	11	10	9	8	6	4	2										
	20				12	11	10	9	8	7	5	3											
	30				12	12	11	10	9	8	7	5	3										
	40				12	11	11	10	9	8	6	5	2										
	50				12	11	10	10	9	7	6	4	1										
	60				12	11	10	9	8	7	6	4											
	80				12	11	10	9	8	6	5	2											
Shut-off PSI		493	450	406	363	319	276	233	189	146	103	59	16										

Submersible Pumps

4" 3200 Series - Dimensions

Thermoplastic

Stainless Steel

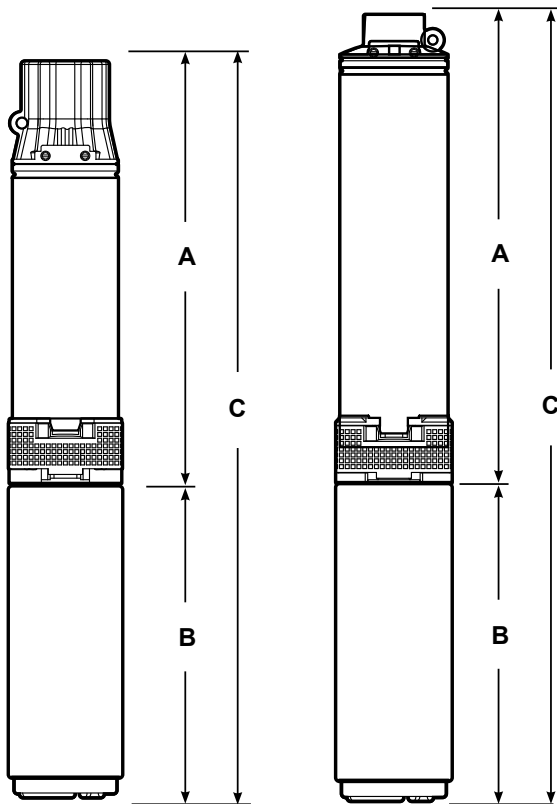

Notes: All lengths are in inches.
All weights are in pounds.

Plastic with 2-Wire Motors

GPM	HP	Stages	A	B	C	PE Wt.	PMA Wt.
5	1/2	13	18.4	9.5	27.9	8	27
	3/4	18	22.6	10.6	33.3	10	31
	1	22	26.0	11.7	37.7	11	35
	1.5	30	34.1	15.1	49.2	17	48
7	1/2	10	15.9	9.5	25.4	7	26
	3/4	13	18.4	10.6	29.0	9	30
	1	18	22.6	11.7	34.3	11	35
	1.5	23	26.8	15.1	41.9	15	46

Plastic with 3-Wire Motors

GPM	HP	Stages	A	B	C	PE Wt.	PMA Wt.
5	1/2	13	18.4	9.5	27.9	8	27
	3/4	18	22.6	10.6	33.3	10	31
	1	22	26.0	11.7	37.7	11	35
	1.5	30	34.1	13.6	47.7	17	48
7	1/2	10	15.9	9.5	25.4	7	26
	3/4	13	18.4	10.6	29.0	9	30
	1	18	22.6	11.7	34.3	11	35
	1.5	23	26.8	13.6	40.4	15	46

Stainless Steel with 2-Wire Motors

GPM	HP	Stages	A	B	C	PE Wt.	PMA Wt.
5	1/2	13	18.4	9.5	27.9	10	29
	3/4	18	22.6	10.6	33.3	12	33
	1	22	26.0	11.7	37.7	13	27
	1.5	30	34.1	15.1	49.2	19	50
7	1/2	10	15.9	9.5	25.4	9	28
	3/4	13	18.4	10.6	29.0	11	32
	1	18	22.6	11.7	34.3	13	37
	1.5	23	26.8	15.1	41.9	17	48

Stainless Steel with 3-Wire Motors

GPM	HP	Stages	A	B	C	PE Wt.	PMA Wt.
5	1/2	13	18.4	9.5	27.9	10	29
	3/4	18	22.6	10.6	33.3	12	33
	1	22	26.0	11.7	37.7	13	27
	1.5	30	34.1	13.6	47.7	19	50
	2	38	40.9	15.1	56.0	23	N/A
7	1/2	10	15.9	9.5	25.4	9	28
	3/4	13	18.4	10.6	29.0	11	32
	1	18	22.6	11.7	34.3	13	37
	1.5	23	26.8	13.6	40.4	17	48
	2	30	34.1	15.1	49.2	20	N/A
3	38	40.9	19.04	59.9	23	N/A	

Submersible Pumps

4" Tri-Seal Pumps - Features



FPS 4400

4" 4400 Tri-Seal

The standard FPS 4400 4" submersible pump features the Tri-Seal floating stage system. This stage system further improves efficiency and protects against wear when pumping abrasives (sand). All FPS 4400 pumps are unconditionally guaranteed against sand locking in abrasive well conditions for one full year. For details on how to become a registered dealer and receive a 5-year warranty, contact your local distributor.

Features:

- 300 series stainless steel hub floats with the impeller maintaining a positive seal.
- Phenolic washer provides downthrust protection.
- Celcon® impeller provides high efficiency performance and abrasion resistance.
- Noryl® diffuser and disc - proven abrasion resistant material.
- Floating stage design allows impeller to float independently.
- Removable, spring-loaded check valve.
- Maximum water temperature: 120 °F / 49 °C.
- Ceramic shaft sleeve and rubber discharge bearing protect shaft and eliminate sand wear.
- Powered by Franklin Electric corrosion-resistant super stainless 4" submersible motors with lightning protection.
- Patented impeller hub seal system seals radially and axially to prevent fluid recirculation, providing high performance in the harshest conditions.

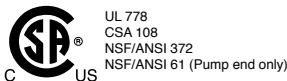

UL 778
CSA 108
NSF/ANSI 372
NSF/ANSI 61 (Pump end only)

Celcon® is a registered trademark of the Celanese Corporation.
Noryl® is a registered trademark of G.E.

Tri-Seal™ Floating Stage System

U.S. Patent No. 7,290,984

Submersible Pumps

4" Tri-Seal Pumps - 5 GPM

Plastic	GPM	HP	Stg.	Volts	2-Wire			3-Wire			
					PMA Model	Order No.	Motor	PMA Model	Order No.	Motor	Control Box
					5	1/2	8	115	5FA05P4-2W115	93780505	2445049004S
	1/2	8	230	5FA05P4-2W230	93780510	2445059004S	5FA05P4-3W230	93780535	2145059004S	2801054915	
	3/4	12	230	5FA07P4-2W230	93780515	2445079004S	5FA07P4-3W230	93780540	2145079004S	2801074915	
	1	15	230	5FA1P4-2W230	93780520	2445089003S	5FA1P4-3W230	93780545	2145089003S	2801084915	
	1.5	21	230	5FA15P4-2W230	93780525	2443099004S	5FA15P4-3W230	93780550	2143099004S	2823008110	

Stainless Steel	GPM	HP	Stg.	Volts	2-Wire			3-Wire			
					PMA Model	Order No.	Motor	PMA Model	Order No.	Motor	Control Box
					5	1/2	8	115	5FA05S4-2W115	93810505	2445049004S
	1/2	8	230	5FA05S4-2W230	93810510	2445059004S	5FA05S4-3W230	93810535	2145059004S	2801054915	
	3/4	12	230	5FA07S4-2W230	93810515	2445079004S	5FA07S4-3W230	93810540	2145079004S	2801074915	
	1	15	230	5FA1S4-2W230	93810520	2445089003S	5FA1S4-3W230	93810545	2145089003S	2801084915	
	1.5	21	230	5FA15S4-2W230	93810525	2443099004S	5FA15S4-3W230	93810550	2143099004S	2823008110	

Stainless Steel - Pump End Assemblies Only				
GPM	HP	Stg.	PE Model	Order No.
5	1/2	8	5FA05S4-PE	93820505
	3/4	12	5FA07S4-PE	93820510
	1	15	5FA1S4-PE	93820515
	1.5	21	5FA15S4-PE	93820520
	2	26	5FA2S4-PE	93820525

Plastic - Pump End Assemblies Only				
GPM	HP	Stg.	PE Model	Order No.
5	1/2	8	5FA05P4-PE	93790505
	3/4	12	5FA07P4-PE	93790510
	1	15	5FA1P4-PE	93790515
	1.5	21	5FA15P4-PE	93790520

Notes: Discharge is 1-1/4" NPT. Maximum diameter across cable guard is 3.90" on all models.

Capacities in U.S. Gallons per Minute

HP	PSI	Depth to Pumping Water Level, or Lift, in Feet. Shaded Areas Indicate Most Efficient Performance																							
		20	40	60	80	100	120	140	160	180	200	240	260	300	360	400	440	480	500	600	700		800	900	1000
1/2	0							7	7	6	6	5	4												Shut-off 315 ft.
	20					8	7	6	6	5	5	3	2												
	30				7	7	6	6	5	5	4	2													
	40			7	7	6	6	5	5	4	3														
	50		7	6	6	6	5	5	4	2															
	60	7	7	6	6	5	4	4	2																
	80	6	6	5	4	3																			
Shut-off PSI		127	119	110	101	93	84	75	67	58	49	32	23												
3/4	0									7	7	7	6	5	4	3									Shut-off 495 ft.
	20									7	7	6	6	5	4	3									
	30									7	7	6	6	5	3										
	40									7	7	6	6	5	4	2									
	50									7	7	6	6	5	4										
	60									7	7	6	6	5	4	3									
	80		7	7	7	6	6	5	4	3	3														
Shut-off PSI		205	196	188	179	171	162	153	145	136	127	110	101	84	58	41	23								
1	0													8	7	6	6	5	4	4					Shut-off 615 ft.
	20													7	7	6	5	4	3						
	30													7	7	6	5	5	3	2					
	40													7	7	6	5	4	3						
	50													7	7	6	5	4							
	60													7	7	6	5	4							
	80													7	7	6	5	4							
Shut-off PSI		257	248	240	231	222	214	205	197	188	179	162	153	136	110	93	75	58	49						
1.5	0															7	7	7	6	5	4	2			Shut-off 835 ft.
	20															7	7	6	6	5	3				
	30															7	7	6	6	6	4	3			
	40															7	7	6	6	6	5	4	2		
	50															7	7	6	6	5	5	3			
	60															7	7	6	6	5	5	3			
	80															7	7	6	5	5	4	2			
Shut-off PSI		352	344	335	326	318	309	300	292	283	274	257	249	231	205	188	171	153	145	101	58	15			

Submersible Pumps

4" Tri-Seal Pumps - 5 GPM

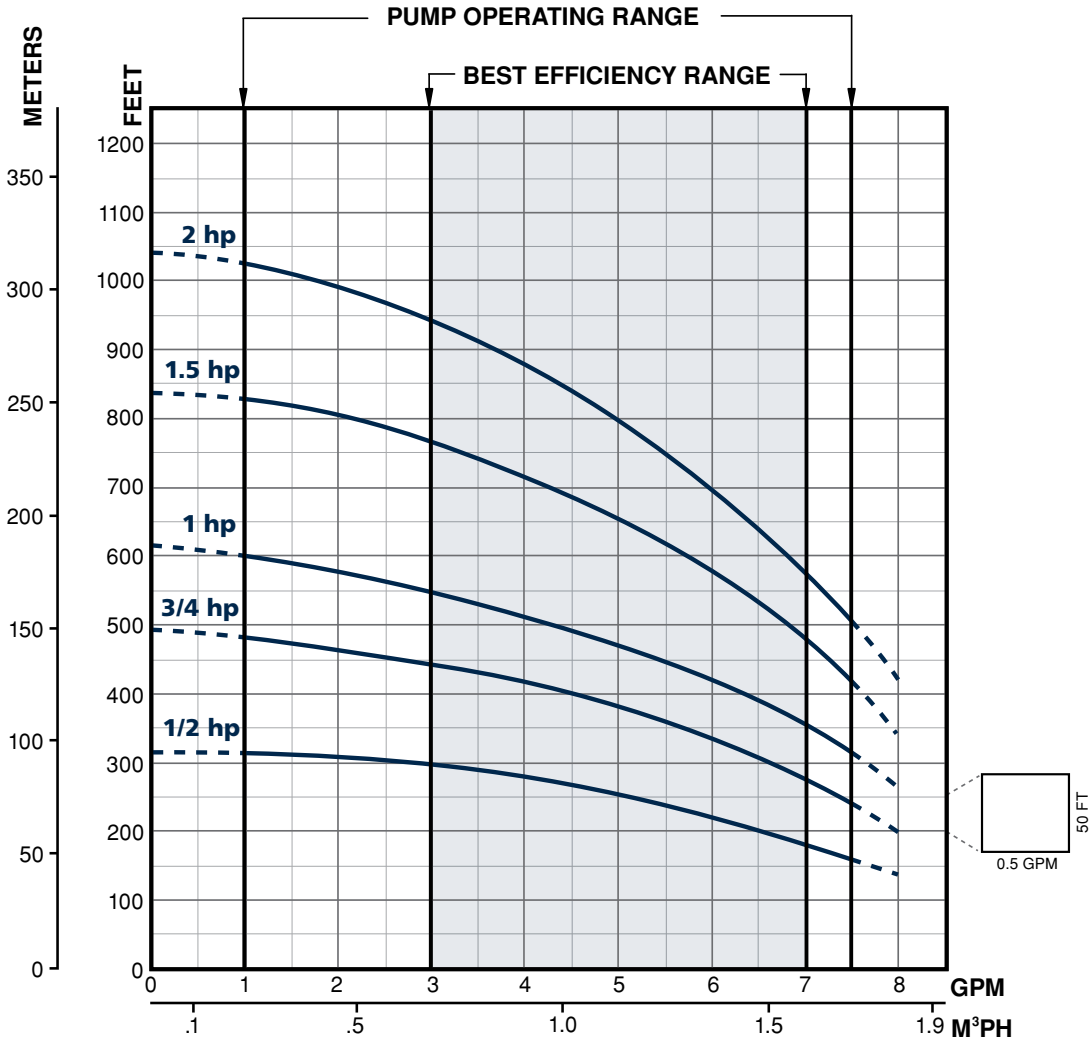

Capacities in U.S. Gallons per Minute

HP	PSI	Depth to Pumping Water Level, or Lift, in Feet. Shaded Areas Indicate Most Efficient Performance																			Shut-off 1040 ft.			
		20	40	60	80	100	120	140	160	180	200	240	260	300	360	400	440	480	500	600		700	800	900
2	0																7	7	7	6	5	4	3	
	20																7	7	7	6	5	4	2	
	30																7	7	7	6	5	3		
	40																7	7	7	6	5	3		
	50																7	7	7	6	5	4	3	
	60																7	7	7	6	5	4	3	
	80																7	7	6	6	5	3		
Shut-off PSI		441	432	424	415	406	398	389	381	372	363	346	337	320	294	277	259	242	233	190	147	104	60	

Notes: 1. Performance shown does not include friction loss in the drop pipe. 2. All performance data is based on rated motor nameplate voltage.

Submersible Pumps

4" Tri-Seal Pumps - 7 GPM

Material	GPM	HP	Stg.	Volts	2-Wire			3-Wire			
					PMA Model	Order No.	Motor	PMA Model	Order No.	Motor	Control Box
					Plastic	7	1/2	7	115	7FA05P4-2W115	93780705
		1/2	7	230	7FA05P4-2W230	93780710	2445059004S	7FA05P4-3W230	93780735	2145059004S	2801054915
		3/4	10	230	7FA07P4-2W230	93780715	2445079004S	7FA07P4-3W230	93780740	2145079004S	2801074915
		1	13	230	7FA1P4-2W230	93780720	2445089003S	7FA1P4-3W230	93780745	2145089003S	2801084915
		1.5	18	230	7FA15P4-2W230	93780725	2443099004S	7FA15P4-3W230	93780750	2143099004S	2823008110
Stainless Steel	7	1/2	7	115	7FA05S4-2W115	93810705	2445049004S	7FA05S4-3W115	93810730	2145049004S	2801044915
		1/2	7	230	7FA05S4-2W230	93810710	2445059004S	7FA05S4-3W230	93810735	2145059004S	2801054915
		3/4	10	230	7FA07S4-2W230	93810715	2445079004S	7FA07S4-3W230	93810740	2145079004S	2801074915
		1	13	230	7FA1S4-2W230	93810720	2445089003S	7FA1S4-3W230	93810745	2145089003S	2801084915
		1.5	18	230	7FA15S4-2W230	93810725	2443099004S	7FA15S4-3W230	93810750	2143099004S	2823008110

GPM	HP	Stg.	PE Model	Order No.
7	1/2	7	7FA05S4-PE	93820705
	3/4	10	7FA07S4-PE	93820710
	1	13	7FA1S4-PE	93820715
	1.5	18	7FA15S4-PE	93820720
	2	24	7FA2S4-PE	93820725
	3	32	7FA3S4-PE	93820730

GPM	HP	Stg.	PE Model	Order No.
7	1/2	7	7FA05P4-PE	93790705
	3/4	10	7FA07P4-PE	93790710
	1	13	7FA1P4-PE	93790715
	1.5	18	7FA15P4-PE	93790720

Notes: Discharge is 1-1/4" NPT. Maximum diameter across cable guard is 3.90" on all models.

Capacities in U.S. Gallons per Minute

HP	PSI	Depth to Pumping Water Level, or Lift, in Feet. Shaded Areas Indicate Most Efficient Performance																								
		20	40	60	80	100	120	140	160	180	200	240	260	300	360	400	440	480	500	600		700	800	900	1000	
1/2	0																									Shut-off 300 ft.
	20																									
	30																									
	40																									
	50																									
	60																									
	80																									
Shut-off PSI		121	112	103	95	86	77	69	60	52	43	26	17													
3/4	0																									Shut-off 422 ft.
	20																									
	30																									
	40																									
	50																									
	60																									
	80																									
Shut-off PSI		174	165	156	148	139	130	122	113	104	96	78	70	52	26											
1	0																									Shut-off 544 ft.
	20																									
	30																									
	40																									
	50																									
	60																									
	80																									
Shut-off PSI		226	218	209	200	192	183	174	166	157	148	131	123	105	79	62	45	27	18							
1.5	0																									Shut-off 765 ft.
	20																									
	30																									
	40																									
	50																									
	60																									
	80																									
Shut-off PSI		322	313	305	296	287	279	270	261	253	244	227	218	201	175	158	140	123	114	71	28					
2	0																									Shut-off 995 ft.
	20																									
	30																									
	40																									
	50																									
	60																									
	80																									
Shut-off PSI		421	412	404	395	386	378	369	360	352	343	326	317	300	274	257	239	222	213	170	127	84	40			

Submersible Pumps

4" Tri-Seal Pumps - 7 GPM

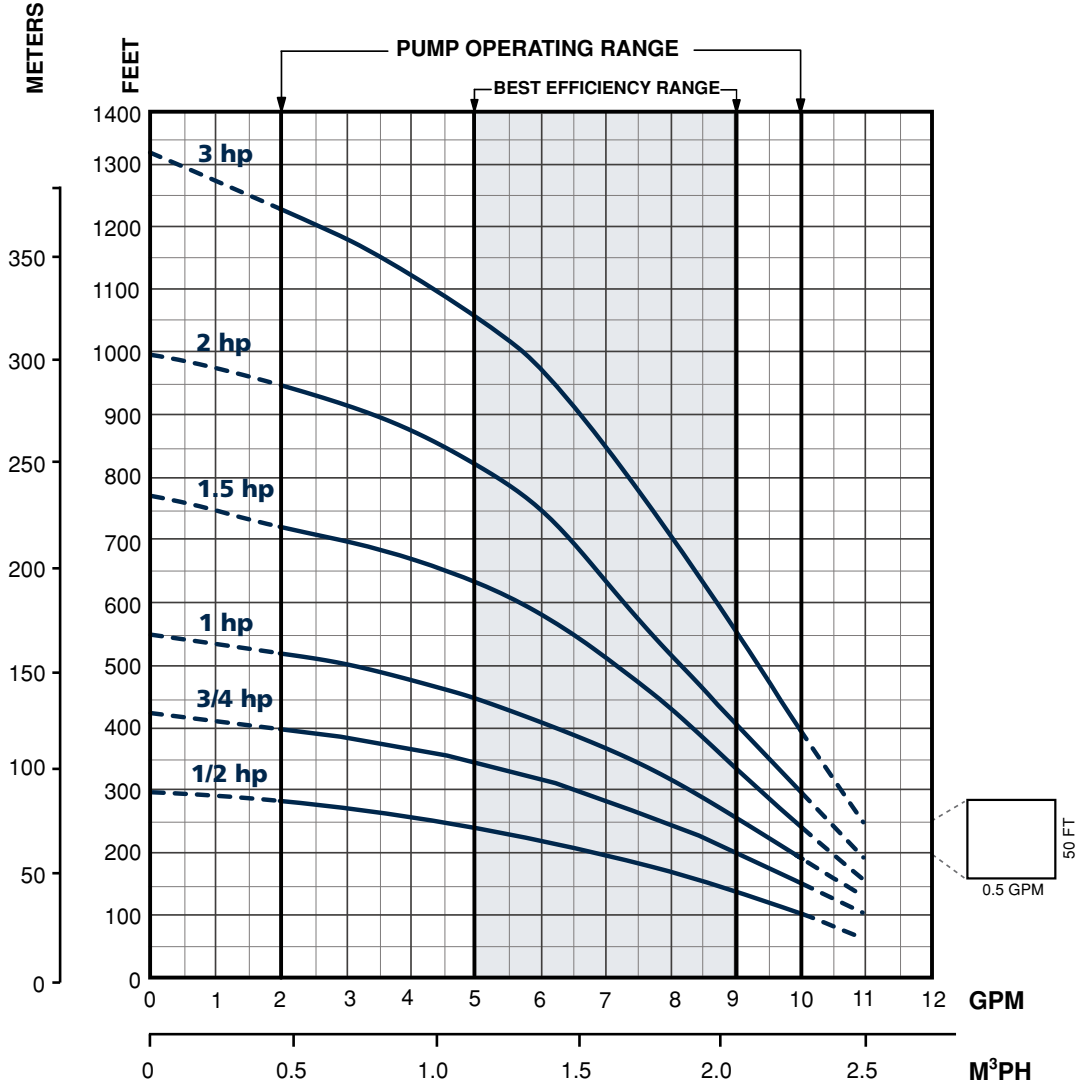

Capacities in U.S. Gallons per Minute

HP	PSI	Depth to Pumping Water Level, or Lift, in Feet. Shaded Areas Indicate Most Efficient Performance														Shut-off 1310 ft.		
		100	200	300	400	500	600	700	800	900	1000	1100	1200	1300	1400			
3	0			10	9	9	8	7	7	6	5	4	2					
	20		10	9	9	8	8	7	6	6	5	3						
	30		10	9	9	8	8	7	6	6	4	3						
	40		10	9	9	8	7	7	6	5	4							
	50	10	10	9	8	8	7	7	6	5	4							
	60	10	10	9	8	8	7	7	6	5	3							
	80	10	9	8	8	7	7	6	5	4	2							
Shut-off PSI		523	480	437	394	350	307	264	221	177	134	91	48					

Notes: 1. Performance shown does not include friction loss in the drop pipe. 2. All performance data is based on rated motor nameplate voltage.

Submersible Pumps

4" Tri-Seal Pumps - 10 GPM

Plastic	GPM	HP	Stg.	Volts	2-Wire			3-Wire			
					PMA Model	Order No.	Motor	PMA Model	Order No.	Motor	Control Box
					10	1/2	6	115	10FA05P4-2W115	93781005	2445049004S
	1/2	6	230	10FA05P4-2W230	93780710	2445059004S	10FA05P4-3W230	93781035	2145059004S	2801054915	
	3/4	8	230	10FA07P4-2W230	93781015	2445079004S	10FA07P4-3W230	93781040	2145079004S	2801074915	
	1	11	230	10FA1P4-2W230	93781020	2445089003S	10FA1P4-3W230	93781045	2145089003S	2801084915	
	1.5	15	230	10FA15P4-2W230	93781025	2443099004S	10FA15P4-3W230	93781050	2143099004S	2823008110	

Stainless Steel	GPM	HP	Stg.	Volts	2-Wire			3-Wire			
					PMA Model	Order No.	Motor	PMA Model	Order No.	Motor	Control Box
					10	1/2	6	115	10FA05S4-2W115	93811005	2445049004S
	1/2	6	230	10FA05S4-2W230	93811010	2445059004S	10FA05S4-3W230	93811035	2145059004S	2801054915	
	3/4	8	230	10FA07S4-2W230	93811015	2445079004S	10FA07S4-3W230	93811040	2145079004S	2801074915	
	1	11	230	10FA1S4-2W230	93811020	2445089003S	10FA1S4-3W230	93811045	2145089003S	2801084915	
	1.5	15	230	10FA15S4-2W230	93811025	2443099004S	10FA15S4-3W230	93811050	2143099004S	2823008110	

Stainless Steel - Pump End Assemblies Only				
GPM	HP	Stg.	PE Model	Order No.
10	1/2	6	10FA05S4-PE	93821005
	3/4	8	10FA07S4-PE	93821010
	1	11	10FA1S4-PE	93821015
	1.5	15	10FA15S4-PE	93821020
	2	18	10FA2S4-PE	93821025
	3	24	10FA3S4-PE	93821030
	5	39	10FA5S4-PE	93821035

Plastic - Pump End Assemblies Only				
GPM	HP	Stg.	PE Model	Order No.
10	1/2	6	10FA05P4-PE	93791005
	3/4	8	10FA07P4-PE	93791010
	1	11	10FA1P4-PE	93791015
	1.5	15	10FA15P4-PE	93791020

Notes: Discharge is 1-1/4" NPT. Maximum diameter across cable guard is 3.90" on all models.

Capacities in U.S. Gallons per Minute

HP	PSI	Depth to Pumping Water Level, or Lift, in Feet. Shaded Areas Indicate Most Efficient Performance																									
		20	40	60	80	100	120	140	160	180	200	240	260	300	360	400	440	480	500	600		700	800	900	1000		
1/2	0					14	13	12	11	10	9	7															Shut-off 244 ft.
	20	14	13	13	12	11	10	8	6	3																	
	30	13	13	12	11	10	8	6	3																		
	40	13	12	11	10	8	6	3																			
	50	12	11	9	8	5	3																				
	60	11	10	7	4																						
	80	8	6	4																							
Shut-off PSI		97	88	80	71	62	54	45	36	28	19																
3/4	0					14	13	13	12	11	10	7	8	4													Shut-off 338 ft.
	20	14	14	13	12	12	11	10	9	8	6	4															
	30	14	14	13	12	12	11	10	9	8	7	3															
	40	14	13	12	12	11	10	9	8	7	6																
	50	13	12	11	11	10	9	8	7	5	3																
	60	12	11	11	10	9	8	6	5																		
	80	11	10	9	8	6	5																				
Shut-off PSI		137	129	120	111	103	94	85	77	68	59	42	34	16													
1	0							14	13	13	12	11	10	9	7	4											Shut-off 444 ft.
	20					14	13	13	12	11	11	9	9	7	3												
	30					14	13	13	12	11	11	10	9	8	6												
	40					14	13	13	12	11	11	10	9	8	7	5											
	50					14	13	12	12	11	11	10	9	8	7	6											
	60					13	12	12	11	11	10	9	8	8	5	4											
	80					12	12	11	10	10	9	8	7	6	5												
Shut-off PSI		183	174	157	148	140	131	123	114	105	97	79	71	53	27	10											
1.5	0									14	13	13	12	12	10	9	9	8	7								Shut-off 615 ft.
	20									14	13	13	12	12	11	11	9	8	7	6	5						
	30									14	13	13	12	12	11	11	10	8	8	6	5	4					
	40									14	13	13	12	12	11	10	10	8	7	6	4						
	50									14	13	13	12	12	11	10	10	9	8	6	5	3					
	60									14	13	13	12	12	11	11	11	10	9	7	6	4					
	80									13	13	13	12	12	11	11	10	9	8	6	3						
Shut-off PSI		257	248	240	231	222	214	205	197	188	179	162	153	136	110	93	75	41	32								
2	0												14	13	13	12	11	10	10	9	8	6				Shut-off 770 ft.	
	20												14	13	13	12	11	10	9	9	8	5					
	30												14	13	13	12	12	10	10	9	8	8	4				
	40												14	13	13	12	12	11	10	9	8	7	3				
	50												14	13	13	12	12	11	11	10	9	8	7	6			
	60												14	13	13	12	12	11	11	10	9	8	7	6			
	80												14	13	13	12	12	11	11	10	9	8	7	6			
Shut-off PSI		324	316	307	298	290	281	272	264	255	246	229	220	203	177	160	143	125	117	73							

Submersible Pumps

4" Tri-Seal Pumps - 10 GPM

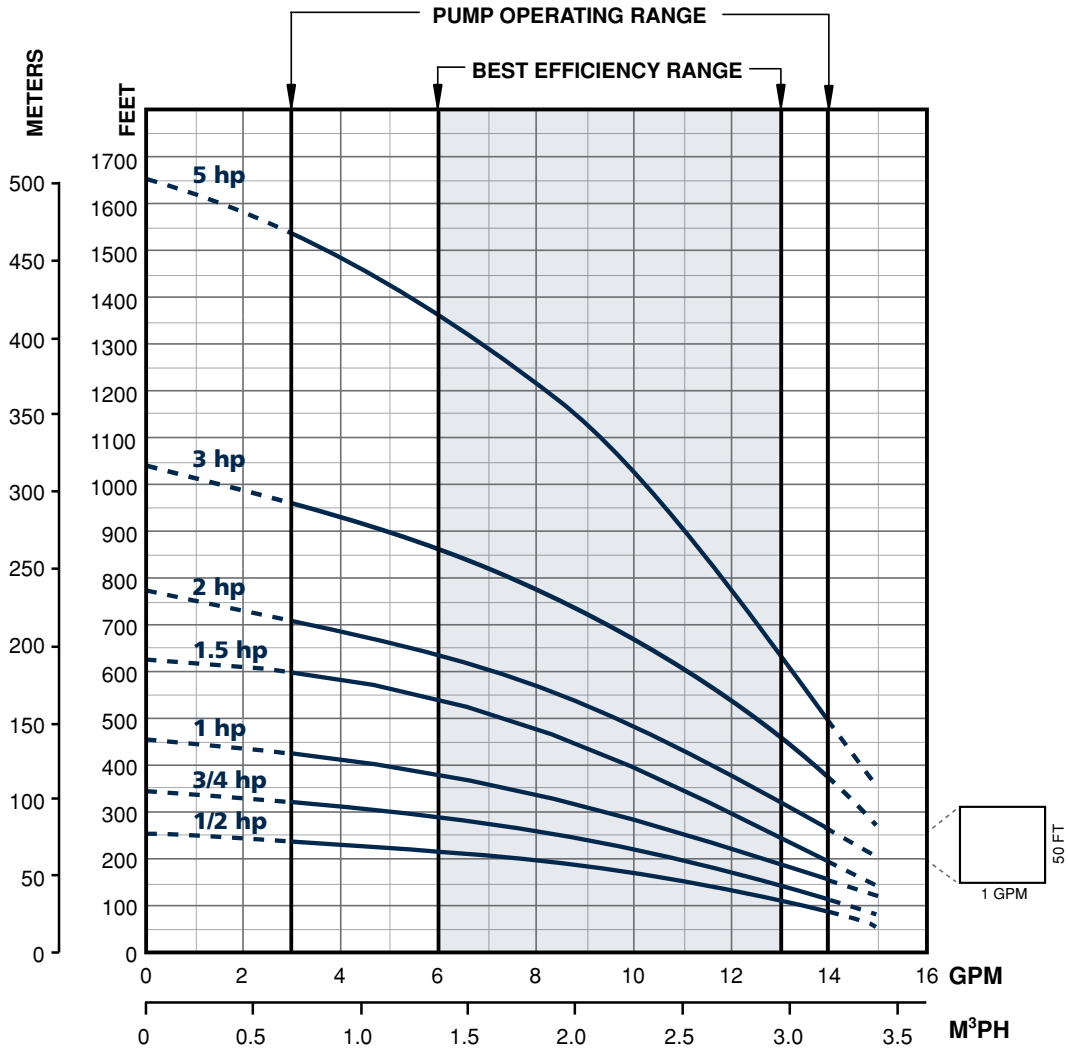

Capacities in U.S. Gallons per Minute

HP	PSI	Depth to Pumping Water Level, or Lift, in Feet. Shaded Areas Indicate Most Efficient Performance														Shut-off										
		20	40	60	80	100	120	140	160	180	200	240	260	300	360		400	440	480	500	600	700	800	900	1000	
3	0														14	13	13	12	12	12	11	9	7	5		Shut-off 1034 ft.
	20													14	13	13	12	12	12	10	8	6	3			
	30											14	14	13	13	12	12	11	10	8	5					
	40										14	14	13	13	12	12	11	11	9	7	4					
	50									14	14	14	13	13	12	12	11	11	9	7	4					
	60								14	14	14	13	13	12	12	11	11	10	9	6	3					
	80							14	14	13	13	13	12	12	11	11	10	10	8	5						
Shut-off PSI		438	430	421	413	404	395	387	378	369	361	343	335	317	291	274	257	240	231	188	144	101	58			
5	0				14	13	13	12	11	11	10	9	8	6	5										Shut-off 1648 ft.	
	20				14	13	12	12	11	10	9	8	7	6	4											
	30				14	13	12	12	11	10	9	8	7	5	4											
	40				14	13	12	11	11	10	9	8	7	5	3											
	50			14	13	13	12	11	10	9	9	7	6	5	3											
	60			14	13	13	12	11	10	9	8	7	6	4												
	80		14	14	13	12	11	11	10	9	8	7	5	3												
Shut-off PSI		670	626	583	540	497	453	410	367	324	280	237	194	151	107											

Notes: 1. Performance shown does not include friction loss in the drop pipe. 2. All performance data is based on rated motor nameplate voltage.

Submersible Pumps

4" Tri-Seal Pumps - 15 GPM

Material	GPM	HP	Stg.	Volts	2-Wire			3-Wire			
					PMA Model	Order No.	Motor	PMA Model	Order No.	Motor	Control Box
					Plastic	15	1/2	4	115	15FA05P4-2W115	93781505
		1/2	4	230	15FA05P4-2W230	93781510	2445059004S	15FA05P4-3W230	93781535	2145059004S	2801054915
		3/4	6	230	15FA07P4-2W230	93781515	2445079004S	15FA07P4-3W230	93781540	2145079004S	2801074915
		1	8	230	15FA1P4-2W230	93781520	2445089003S	15FA1P4-3W230	93781545	2145089003S	2801084915
		1.5	11	230	15FA15P4-2W230	93781525	2443099004S	15FA15P4-3W230	93781550	2143099004S	2823008110
Stainless Steel	15	1/2	4	115	15FA05S4-2W115	93811505	2445049004S	15FA05S4-3W115	93811530	2145049004S	2801044915
					15FA05S4-2W230	93811510	2445059004S	15FA05S4-3W230	93811535	2145059004S	2801054915
					15FA07S4-2W230	93811515	2445079004S	15FA07S4-3W230	93811540	2145079004S	2801074915
		1	8	230	15FA1S4-2W230	93811520	2445089003S	15FA1S4-3W230	93811545	2145089003S	2801084915
		1.5	11	230	15FA15S4-2W230	93811525	2443099004S	15FA15S4-3W230	93811550	2143099004S	2823008110

GPM	HP	Stg.	PE Model	Order No.
15	1/2	4	15FA05S4-PE	93821505
	3/4	6	15FA07S4-PE	93821510
	1	8	15FA1S4-PE	93821515
	1.5	11	15FA15S4-PE	93821520
	2	14	15FA2S4-PE	93821525
	3	19	15FA3S4-PE	93821530
	5	31	15FA5S4-PE	93821535

GPM	HP	Stg.	PE Model	Order No.
15	1/2	4	15FA05P4-PE	93791505
	3/4	6	15FA07P4-PE	93791510
	1	8	15FA1P4-PE	93791515
	1.5	11	15FA15P4-PE	93791520

Notes: Discharge is 1-1/4" NPT. Maximum diameter across cable guard is 3.90" on all models.

Capacities in U.S. Gallons per Minute

HP	PSI	Depth to Pumping Water Level, or Lift, in Feet. Shaded Areas Indicate Most Efficient Performance																								
		20	40	60	80	100	120	140	160	180	200	240	260	300	360	400	440		480	500	600	700	800	900	1000	1100
1/2	0			20	18	16	13	9	4																	
	20	19	17	15	12	8																				
	30	17	14	11	7																					
	40	14	11	6																						
	50	10	5																							
	60	4																								
	80																									
Shut-off PSI	65	56	48	39	30	22	13	4																		
3/4	0			20	19	18	16	15	13	11																
	20		20	19	17	16	14	12	10	7																
	30	20	18	17	16	14	12	10	6																	
	40	18	17	15	14	12	9	6																		
	50	17	15	13	11	9	5																			
	60	15	13	11	8	4																				
	80	10	7																							
Shut-off PSI	103	94	85	77	68	59	51	42	33	25																
1	0				20	19	18	17	16	15	13	11	7													
	20			20	19	18	17	16	15	14	12	9	6													
	30	20	20	19	18	17	16	15	14	12	10	6														
	40	19	19	18	17	16	15	13	12	10	8															
	50	18	18	17	16	14	13	12	10	8	5															
	60	17	16	15	14	13	11	10	7	4																
	80	15	14	12	11	9	6																			
Shut-off PSI	140	131	123	114	105	97	88	79	71	62	45	36	19													
1.5	0					20	20	19	19	18	17	16	14	11	8	4										
	20				20	20	19	18	18	17	16	15	14	12	7											
	30			20	20	19	18	18	17	16	15	14	13	10	5											
	40		20	19	19	18	18	17	16	15	15	13	11	9												
	50	20	19	19	18	17	17	16	15	14	13	11	10	7												
	60	19	19	18	17	17	16	15	14	13	12	10	8	4												
	80	18	17	16	16	15	14	13	12	11	9	6														
Shut-off PSI	193	185	176	167	159	150	141	133	124	115	98	89	72	46	29	11										
2	0						20	20	19	18	18	17	15	13	12	10	8									
	20					20	20	19	19	18	17	17	15	13	11	9	7	5								
	30				20	20	19	19	18	18	16	16	14	12	10	8	5									
	40			20	20	20	19	19	18	18	17	16	16	14	11	9	6									
	50		20	20	19	19	19	18	17	17	16	15	14	13	10	7	4									
	60	20	20	19	19	18	18	17	17	16	16	14	13	12	9	6										
	80	19	19	18	18	17	17	16	15	15	14	12	11	9	5											
Shut-off PSI	249	240	231	223	214	205	197	188	179	171	153	145	127	101	84	67	49	41								

Submersible Pumps

4" Tri-Seal Pumps - 15 GPM

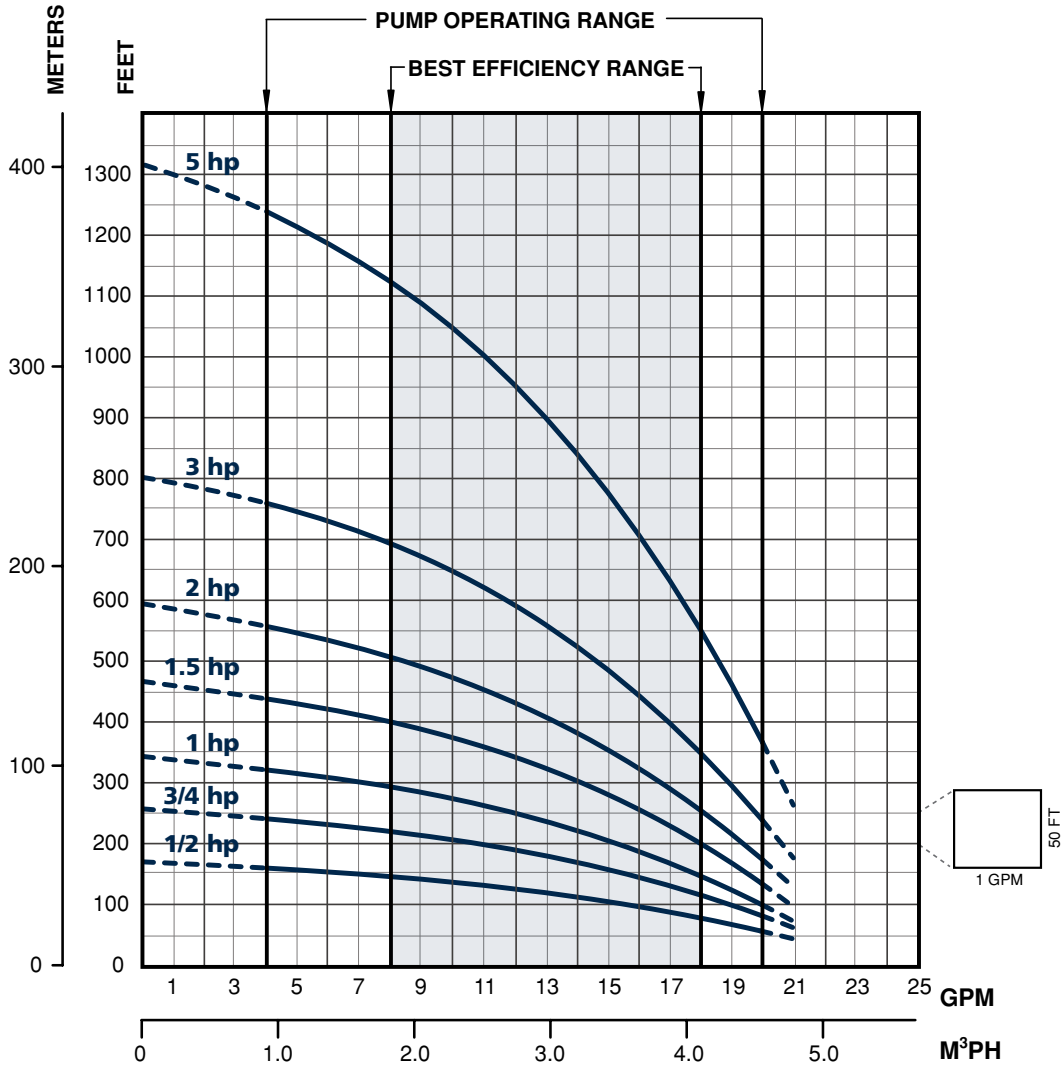

Capacities in U.S. Gallons per Minute

HP	PSI	Depth to Pumping Water Level, or Lift, in Feet. Shaded Areas Indicate Most Efficient Performance																										
		20	40	60	80	100	120	140	160	180	200	240	260	300	360	400	440	480		500	600	700	800	900	1000	1100	1200	
3	0																											Shut-off 802 ft.
	20																											
	30																											
	40																											
	50																											
	60																											
	80	20	20	20	20	19	19	19	18	18	17	16	16	15	13	12	11	9	8									
Shut-off PSI	339	330	321	313	304	295	287	278	269	261	243	235	217	191	174	157	139	131	87	44								
5	0																											Shut-off 1316 ft.
	20																											
	30																											
	40																											
	50																											
	60																											
	80																											
Shut-off PSI	561	553	544	535	527	518	509	501	492	483	466	457	440	414	397	379	362	353	310	267	224	180	137	94	50			

Notes: 1. Performance shown does not include friction loss in the drop pipe. 2. All performance data is based on rated motor nameplate voltage.

Submersible Pumps

4" Tri-Seal Pumps - 20 GPM

Plastic	GPM	HP	Stg.	Volts	2-Wire			3-Wire			
					PMA Model	Order No.	Motor	PMA Model	Order No.	Motor	Control Box
					20	3/4	5	230	20FA07P4-2W230	93782015	2445079004S
	1	7	230	20FA1P4-2W230	93782020	2445089003S	20FA1P4-3W230	93782045	2145089003S	2801084915	
	1.5	10	230	20FA15P4-2W230	93782025	2443099004S	20FA15P4-3W230	93782050	2143099004S	2823008110	

Stainless Steel	GPM	HP	Stg.	Volts	2-Wire			3-Wire			
					PMA Model	Order No.	Motor	PMA Model	Order No.	Motor	Control Box
					20	3/4	5	230	20FA07S4-2W230	93812015	2445079004S
	1	7	230	20FA1S4-2W230	93812020	2445089003S	20FA1S4-3W230	93812045	2145089003S	2801084915	
	1.5	10	230	20FA15S4-2W230	93812025	2443099004S	20FA15S4-3W230	93812050	2143099004S	2823008110	

GPM	HP	Stg.	PE Model	Order No.
20	3/4	5	20FA07S4-PE	93822010
	1	7	20FA1S4-PE	93822015
	1.5	10	20FA15S4-PE	93822020
	2	12	20FA2S4-PE	93822025
	3	16	20FA3S4-PE	93822030
	5	26	20FA5S4-PE	93822035
	7.5	39	20FA7S4-PE	93822040
	10	52	20FA10S4-PE	93822045

GPM	HP	Stg.	PE Model	Order No.
20	3/4	5	20FA07P4-PE	93792010
	1	7	20FA1P4-PE	93792015
	1.5	10	20FA15P4-PE	93792020

Notes: Discharge is 1-1/4" NPT. Maximum diameter across cable guard is 3.90" on all models.

Capacities in U.S. Gallons per Minute

HP	PSI	Depth to Pumping Water Level, or Lift, in Feet. Shaded Areas Indicate Most Efficient Performance																						
		20	40	60	80	100	120	140	160	180	200	240	260	300	360	400	440	480	500		600	700	800	900
3/4	0				24	22	21	18	14															
	20				23	21	19	17	12															
	30		23	21	19	17	11																	
	40		21	19	17	10																		
	50		19	16	10																			
	60		14																					
Shut-off PSI		74	65	56	48	39	30	22	13															
1	0				27	26	24	22	20	18	11													
	20				27	26	24	22	20	18	15	8												
	30		27	26	24	22	19	17	14	7														
	40		27	25	23	21	19	17	13															
	50		25	23	21	19	16	12																
	60		23	21	18	16	11																	
70		20	18	15	10																			
80		18	15	9																				
Shut-off PSI		100	91	83	74	66	57	48	40	31	22	5												
1.5	0								27	26	24	22	20	17	6									
	20								27	25	24	23	21	18	16	10								
	30								26	25	24	22	21	20	16	13								
	40								26	25	23	22	21	19	18	13	8							
	50			27	26	25	23	22	21	19	17	15	7											
	60		27	26	24	23	22	20	19	17	15	11												
70		26	24	23	21	20	19	17	14	11	5													
80		24	23	21	20	18	16	14	10															
Shut-off PSI		156	147	138	130	121	112	104	95	86	78	60	52	34	8									
2	0												24	23	20	16	12							
	20												24	21	20	17	12							
	30												24	23	22	20	19	16						
	40												24	23	22	21	19	17	14					
	50									24	23	22	20	19	16	14	10							
	60									24	23	22	20	19	18	14	12							
80			24	23	21	20	19	18	16	14														
Shut-off PSI		187	179	170	161	153	144	135	127	118	110	92	84	66	40	23								
3	0													24	23	22	20	18	16	14				
	20													24	23	20	17	15	12	10				
	30													24	23	21	18	16	13	10				
	40													24	23	22	20	17	14	11				
	50													24	24	22	21	19	16	13				
	60													24	24	23	21	20	18	14	10			
80													24	23	22	20	18	17	15	10				
Shut-off PSI		251	242	234	225	216	208	199	190	182	173	156	147	130	104	87	69	52	43					

Submersible Pumps

4" Tri-Seal Pumps - 20 GPM

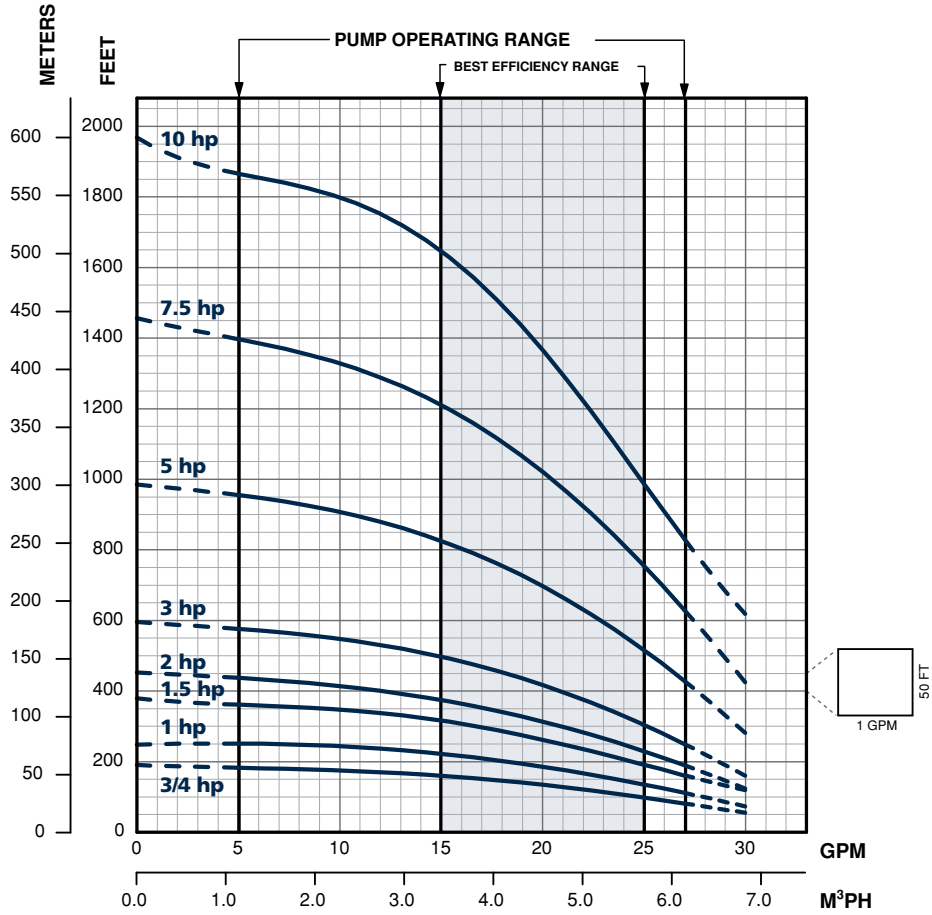

Capacities in U.S. Gallons per Minute

HP	PSI	Depth to Pumping Water Level, or Lift, in Feet. Shaded Areas Indicate Most Efficient Performance																						
		20	40	60	80	100	120	140	160	180	200	240	260	300	360	400	440	480	500	600	700	800	900	1000
5	0																		24	23	20	16		
	20																		24	21	18	13		
	30																		24	23	20	17	11	
	40																		24	23	20	16	10	
	50																		24	22	22	17	15	
	60																		24	23	21	18	14	
	80																		24	23	22	21	18	14
Shut-off PSI		416	408	399	390	382	373	364	356	347	339	321	313	295	269	252	235	217	209	165	122	79		
7.5	0																							
	20																							
	30																							
	40																							
	50																							
	60																							
	80																							
Shut-off PSI		440	423	414	371	327	284	241	197	154	111	68	24											
10	0																							
	20																							
	30																							
	40																							
	50																							
	60																							
	80																							
Shut-off PSI		662	644	636	592	549	506	462	419	376	333	289	246	203	159	116	73							

Notes: 1. Performance shown does not include friction loss in the drop pipe. 2. All performance data is based on rated motor nameplate voltage.

Submersible Pumps

4" Tri-Seal Pumps - 25 GPM

Material	GPM	HP	Stg.	Volts	2-Wire			3-Wire			
					PMA Model	Order No.	Motor	PMA Model	Order No.	Motor	Control Box
					25	1 1.5	6 8	230 230	25FA1P4-2W230 25FA15P4-2W230	93782520 93782525	2445089003S 2443099004S

Material	GPM	HP	Stg.	Volts	2-Wire			3-Wire			
					PMA Model	Order No.	Motor	PMA Model	Order No.	Motor	Control Box
					25	1 1.5	6 8	230 230	25FA1S4-2W230 25FA15S4-2W230	93812520 93812525	2445089003S 2443099004S

Stainless Steel - Pump End Assemblies Only				
GPM	HP	Stg.	PE Model	Order No.
25	1	6	25FA1S4-PE	93822515
	1.5	8	25FA15S4-PE	93822520
	2	10	25FA2S4-PE	93822525
	3	14	25FA3S4-PE	93822530
	5	23	25FA5S4-PE	93822535
	7.5	35	25FA7S4-PE	93822540
	10	44	25FA10S4-PE	93822545

Plastic - Pump End Assemblies Only				
GPM	HP	Stg.	PE Model	Order No.
25	1 1.5	6 8	25FA1P4-PE 25FA15P4-PE	93792515 93792520

Notes: Discharge is 1-1/4" NPT. Maximum diameter across cable guard is 3.90" on all models.

Capacities in U.S. Gallons per Minute

HP	PSI	Depth to Pumping Water Level, or Lift, in Feet. Shaded Areas Indicate Most Efficient Performance																							
		20	40	60	80	100	120	140	160	180	200	240	260	300	360	400	440	480	500	600		700	800	900	1000
1	0			35	33	31	28	26	24	21	17														Shut-off 222 ft
	20		32	30	28	25	22	18	15																
	30	32	29	27	25	22	19																		
	40	29	27	25	22	19																			
	50	26	24	21	16																				
	60	24	21	17																					
Shut-off PSI		87	79	70	61	53	44	35	27	18	10														
1.5	0					33	31	29	27	25	21	19												Shut-off 297 ft	
	20				32	30	28	26	24	22	19														
	30			32	30	28	26	24	22	19	16														
	40	33	32	29	27	25	23	21	19	15															
	50	32	29	27	25	23	21	18																	
	60	29	27	25	23	20	18																		
80	24	22	20	17																					
Shut-off PSI		120	111	103	94	85	77	68	59	51	42	25	16												
2	0					33	32	30	28	25	24	20												Shut-off 375 ft	
	20				34	33	31	29	28	26	25	21	20												
	30			34	33	31	29	28	26	24	23	19	17												
	40		34	33	31	29	28	26	24	23	21	17													
	50	33	32	30	29	27	26	24	22	20	18														
	60	32	30	28	27	26	24	22	20	18															
80	28	26	25	23	21	20	17																		
Shut-off PSI		154	145	136	128	119	110	102	93	84	76	58	50	32											
3	0								33	32	30	29	28	24	22	19	15							Shut-off 519 ft	
	20					33	32	32	31	30	28	27	25	22	19										
	30					33	32	32	31	30	29	27	26	24	20										
	40				33	32	32	31	30	29	28	26	25	22	18										
	50			33	32	31	31	30	29	28	27	24	23	21	15										
	60		33	32	31	31	30	29	28	26	25	23	22	19											
80	32	31	30	29	28	27	26	25	24	23	20	19	15												
Shut-off PSI		216	207	199	190	181	173	164	155	147	138	121	112	95	69	52	34	17							
5	0												33	32	31	30	28	28	24	20				Shut-off 833 ft	
	20												33	32	30	30	28	27	26	22	17				
	30												33	33	31	30	28	27	26	25	21	15			
	40												33	32	32	31	29	28	27	25	24	20			
	50									33	33	32	31	30	28	27	25	24	23	19					
	60								33	33	32	31	31	30	28	26	25	23	22	18					
80					33	33	32	31	31	30	29	28	26	25	23	21	20								
Shut-off PSI		352	343	326	317	309	300	291	283	274	257	248	231	205	187	170	153	144	101	58					

Submersible Pumps

4" Tri-Seal Pumps - 25 GPM

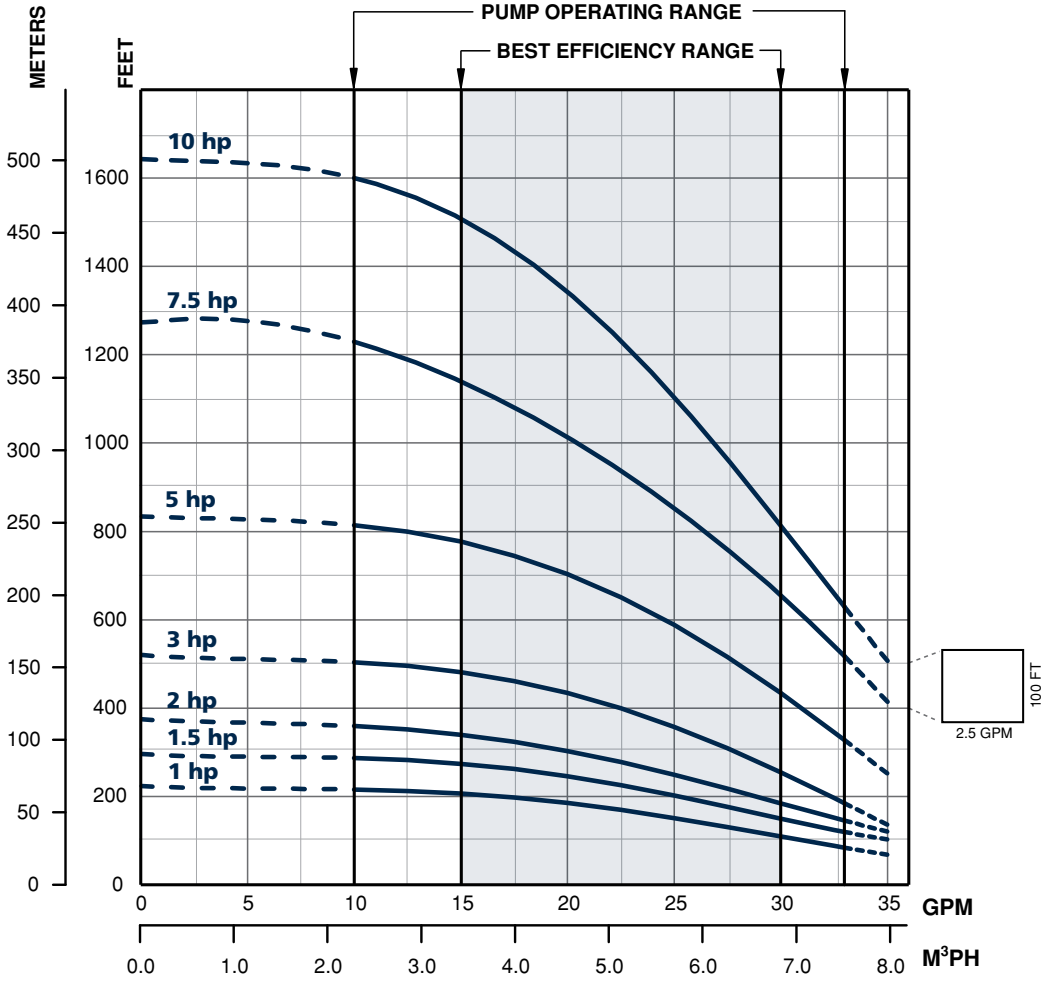

Capacities in U.S. Gallons per Minute

HP	PSI	Depth to Pumping Water Level, or Lift, in Feet. Shaded Areas Indicate Most Efficient Performance																	
		300	360	400	440	480	500	600	700	800	900	1000	1100	1200	1300	1400	1500	1600	1700
7.5	0																		
	20					33	32	32	31	29	26	23	20	17	12				
	30				33	33	32	32	30	27	24	21	18	14					
	40				33	32	32	31	29	27	24	21	17	12					
	50			33	33	32	31	31	29	26	23	20	17						
	60			33	32	32	31	31	28	25	22	19	16						
	80	33	32	32	31	30	30	27	24	21	18	13							
Shut-off PSI		425	399	382	364	347	338	295	252	208	165	122	78	35					
10	0							33	32	30	29	27	25	23	21	19	15	10	
	20							33	31	30	28	26	24	22	20	17	13		
	30							32	31	29	27	26	24	22	19	17	12		
	40						33	32	30	29	27	25	23	21	19	16	10		
	50					33	33	32	30	28	27	25	23	21	18	15			
	60					33	33	31	30	28	26	24	22	20	18	14			
	80			33	32	32	31	29	27	25	23	21	19	16	11				
Shut-off PSI		581	555	538	520	503	494	451	408	365	321	278	235	191	148	105	61	18	

Notes: 1. Performance shown does not include friction loss in the drop pipe. 2. All performance data is based on rated motor nameplate voltage.

Submersible Pumps

4" Tri-Seal Pumps - Dimensions

Stainless Steel

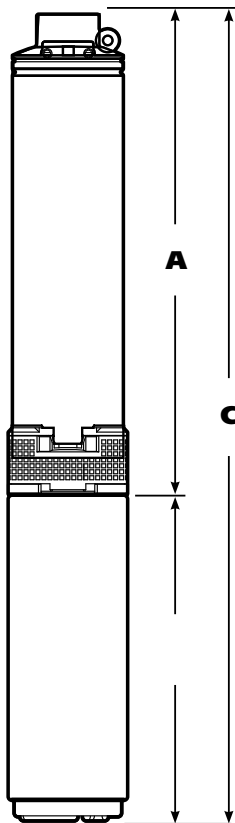

Thermoplastic

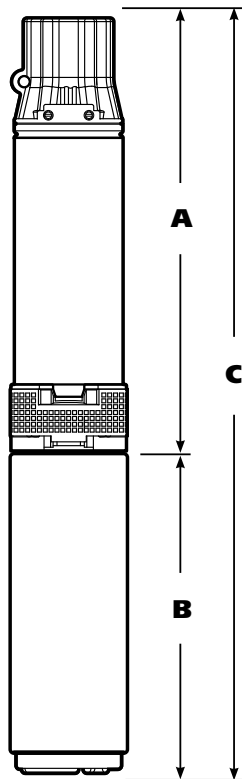

Notes: All lengths are in inches
 All weights are in pounds
 Maximum diameter with cable guard is 3.90"

Plastic with 2-Wire Motors

GPM	HP	Stages	A	B	C	PE Wt.	PMA Wt.
5	1/2	8	14.12	9.51	23.63	8	26
	3/4	12	17.41	10.64	28.05	9	30
	1	15	19.87	11.73	31.60	10	34
	1.5	21	24.81	15.10	39.91	12	43
7	1/2	7	13.30	9.51	22.81	7	25
	3/4	10	15.76	10.64	26.40	8	29
	1	13	18.23	11.73	29.96	10	34
	1.5	18	22.34	15.10	37.44	11	42
10	1/2	6	12.97	9.51	22.48	7	25
	3/4	8	14.69	10.64	25.33	8	29
	1	11	17.44	11.73	29.17	9	33
	1.5	15	21.06	15.10	36.16	10	41
15	1/2	4	11.45	9.51	20.96	6	24
	3/4	6	12.97	10.64	23.61	7	28
	1	8	14.69	11.73	26.42	8	32
	1.5	11	17.44	15.10	32.54	9	40
20	3/4	5	13.65	10.64	24.29	6	28
	1	7	16.10	11.73	27.83	7	31
	1.5	10	19.77	15.10	34.87	8	39
25	1	6	14.88	11.73	26.61	7	31
	1.5	8	17.32	15.10	32.42	8	39

Plastic with 3-Wire Motors

GPM	HP	Stages	A	B	C	PE Wt.	PMA Wt.
5	1/2	8	14.12	9.51	23.63	8	27
	3/4	12	17.41	10.64	28.05	9	30
	1	15	19.87	11.73	31.60	10	34
	1.5	21	24.81	13.60	38.41	12	40
7	1/2	7	13.30	9.51	22.81	7	26
	3/4	10	15.76	10.64	26.40	8	29
	1	13	18.23	11.73	29.96	10	34
	1.5	18	22.34	13.60	35.94	11	39
10	1/2	6	12.97	9.51	22.48	7	26
	3/4	8	14.69	10.64	25.33	8	29
	1	11	17.44	11.73	29.17	9	33
	1.5	15	21.06	13.60	34.66	10	38
15	1/2	4	11.45	9.51	20.96	6	25
	3/4	6	12.97	10.64	23.61	7	28
	1	8	14.69	11.73	26.42	8	32
	1.5	11	17.44	13.60	31.04	9	37
20	3/4	5	13.65	10.64	24.29	6	28
	1	7	16.10	11.73	27.83	7	31
	1.5	10	19.77	13.60	33.37	8	36
25	1	6	14.88	11.73	26.61	7	31
	1.5	8	17.32	15.10	30.92	8	36

Note: PE - Pump end only PMA - Pump and motor assembly

Submersible Pumps

4" Tri-Seal Pumps - Dimensions

Stainless Steel with 2-Wire Motors

GPM	HP	Stages	A	B	C	PE Wt.	PMA Wt.
5	1/2	8	13.57	9.51	23.08	10	28
	3/4	12	16.86	10.64	27.50	12	33
	1	15	19.33	11.73	31.06	14	38
	1.5	21	24.26	15.10	39.36	17	48
7	1/2	7	12.75	9.51	22.26	9	27
	3/4	10	15.22	10.64	25.86	11	32
	1	13	17.68	11.73	29.41	13	37
	1.5	18	21.80	15.10	36.90	15	46
10	1/2	6	12.39	9.51	21.90	9	27
	3/4	8	14.14	10.64	24.78	10	31
	1	11	16.85	11.73	28.58	11	35
	1.5	15	20.48	15.10	35.58	14	45
15	1/2	4	10.64	9.51	20.15	7	25
	3/4	6	12.39	10.64	23.03	9	30
	1	8	14.14	11.73	25.87	10	34
	1.5	11	16.85	15.10	31.95	11	42
20	3/4	5	13.10	10.64	23.74	8	29
	1	7	15.55	11.73	27.28	9	33
	1.5	10	19.22	15.10	34.32	11	42
25	1	6	14.33	11.73	26.06	9	33
	1.5	8	16.77	15.10	31.87	10	41

Note: PE - Pump end only
PMA - Pump and motor assembly

Stainless Steel with 3-Wire Motors

GPM	HP	Stages	A	B	C	PE Wt.	PMA Wt.
5	1/2	8	13.57	9.51	23.08	10	29
	3/4	12	16.86	10.64	27.50	12	33
	1	15	19.33	11.73	31.06	14	38
	1.5	21	24.26	13.60	37.86	17	45
	2	26	30.46	15.10	45.56	20	N/A
7	1/2	7	12.75	9.51	22.26	9	28
	3/4	10	15.22	10.64	25.86	11	32
	1	13	17.68	11.73	29.41	13	37
	1.5	18	21.80	13.60	35.40	15	43
	2	24	26.73	15.10	41.83	19	N/A
10	3	32	35.39	19.04	54.43	23	N/A
	1/2	6	12.39	9.51	21.90	9	28
	3/4	8	14.14	10.64	24.78	10	31
	1	11	16.85	11.73	28.58	11	35
	1.5	15	20.48	13.60	34.08	14	42
15	2	18	25.26	15.10	40.36	15	N/A
	3	24	30.70	19.04	49.74	19	N/A
	5	39	44.20	29.19	73.39	27	N/A
	1/2	4	10.64	9.51	20.15	7	26
	3/4	6	12.39	10.64	23.03	9	30
15	1	8	14.14	11.73	25.87	10	34
	1.5	11	16.85	13.60	30.45	11	39
	2	14	19.57	15.10	34.67	13	N/A
	3	19	26.17	19.04	45.21	16	N/A
	5	31	37.00	29.19	66.19	23	N/A
20	3/4	5	13.10	10.64	23.74	8	29
	1	7	15.55	11.73	27.28	9	33
	1.5	10	19.22	13.60	32.82	11	39
	2	12	21.66	15.10	36.76	12	N/A
	3	16	26.55	19.04	45.59	14	N/A
	5	26	40.86	29.19	70.05	20	N/A
	7.5	39	60.77	29.60	90.37	27	N/A
10	52	76.66	32.60	109.26	35	N/A	
25	1	6	14.33	11.73	26.06	9	33
	1.5	8	16.77	13.60	30.37	10	38
	2	10	19.22	15.10	34.32	11	N/A
	3	14	24.11	19.04	43.15	13	N/A
	5	23	37.19	28.19	66.38	18	N/A
	7.5	35	55.88	29.60	85.48	25	N/A
10	44	66.88	32.60	99.48	30	N/A	

4" Series V Pumps - Features



4" Submersible Series V

The standard FPS Series Five submersible pump features unique hydraulics that improve efficiency and minimize wear even when pumping abrasives. Discharge and motor brackets are available in thermoplastic or stainless steel with a removable check valve system. Available in 5, 7, 10, 15, 20, and 25 gpm, 1/2 - 5 horsepower. For details on how to become a registered dealer and receive a 5-year warranty, contact your local distributor.

Features:

- 6 performance ranges: 5, 7, 10, 15, 20, and 25 gpm.
- Horsepower ranges: 1/2 - 5.
- Discharge head and motor bracket produced with industry proven, engineered materials. Available in 300 series stainless steel or high quality thermoplastic resins.
- Large wrench flat area on the discharge head for ease of installation.
- Dry run designed top bearing positively supports the 300 series stainless steel 7/16" hex shaft.
- Removable internal check valve.
- Powered by Franklin Electric corrosion-resistant super stainless 4" submersible motors with lightning protection.
- Maximum water temperature with proper flow is 120 °F/49 °C. Consult factory for details.

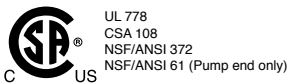

Submersible Pumps

4" Series V Pumps - 5 GPM

Plastic	GPM	HP	Stg.	Volts	2-Wire			3-Wire			
					PMA Model	Order No.	Motor	PMA Model	Order No.	Motor	Control Box
					5	1/2	8	115	5FV05P4-2W115	95400505	2445049004S
	1/2	8	230	5FV05P4-2W230	95400510	2445059004S	5FV05P4-3W230	95400535	2145059004S	2801054915	
	3/4	12	230	5FV07P4-2W230	95400515	2445079004S	5FV07P4-3W230	95400540	2145079004S	2801074915	
	1	15	230	5FV1P4-2W230	95400520	2445089003S	5FV1P4-3W230	95400545	2145089003S	2801084915	
	1.5	21	230	5FV15P4-2W230	95400525	2443099004S	5FV15P4-3W230	95400550	2143099004S	2823008110	

Stainless Steel	GPM	HP	Stg.	Volts	2-Wire			3-Wire			
					PMA Model	Order No.	Motor	PMA Model	Order No.	Motor	Control Box
					5	1/2	8	115	5FV05S4-2W115	95420505	2445049004S
	1/2	8	230	5FV05S4-2W230	95420510	2445059004S	5FV05S4-3W230	95420535	2145059004S	2801054915	
	3/4	12	230	5FV07S4-2W230	95420515	2445079004S	5FV07S4-3W230	95420540	2145079004S	2801074915	
	1	15	230	5FV1S4-2W230	95420520	2445089003S	5FV1S4-3W230	95420545	2145089003S	2801084915	
	1.5	21	230	5FV15S4-2W230	95420525	2443099004S	5FV15S4-3W230	95420550	2143099004S	2823008110	

Stainless Steel - Pump End Assemblies Only				
GPM	HP	Stg.	PE Model	Order No.
5	1/2	8	5FV05S4-PE	95430500
	3/4	12	5FV07S4-PE	95430501
	1	15	5FV1S4-PE	95430502
	1.5	21	5FV15S4-PE	95430503
	2	26	5FV2S4-PE	95430504

Plastic - Pump End Assemblies Only				
GPM	HP	Stg.	PE Model	Order No.
5	1/2	8	5FV05P4-PE	95410500
	3/4	12	5FV07P4-PE	95410501
	1	15	5FV1P4-PE	95410502
	1.5	21	5FV15P4-PE	95410503

Notes: Discharge is 1-1/4" NPT. Maximum diameter across cable guard is 3.90" on all models.

Capacities in U.S. Gallons per Minute

HP	PSI	Depth to Pumping Water Level, or Lift, in Feet. Shaded Areas Indicate Most Efficient Performance																										
		20	40	60	80	100	120	140	160	180	200	240	260	300	360	400	440	480	500	600	700		800	900	1000			
1/2	0										7	7	6	6	5	4											Shut-off 315 ft.	
	20					8	7	6	6	5	5	3	2															
	30				7	7	6	6	5	5	4	2																
	40			7	7	6	6	5	5	4	3																	
	50		7	6	6	6	5	5	4	2																		
	60	7	7	6	6	5	4	4	2																			
	80	6	6	5	4	3																						
Shut-off PSI		127	119	110	101	93	84	75	67	58	49	32	23															
3/4	0										7	7	7	7	6	5	4	3									Shut-off 495 ft.	
	20										7	7	7	6	6	5	4	3										
	30										7	7	7	6	6	5	3											
	40										7	7	7	6	6	5	4	2										
	50										7	7	7	6	6	5	4											
	60										7	7	7	6	6	5	4	3										
	80		7	7	7	6	6	5	4	3	3																	
Shut-off PSI		205	196	188	179	171	162	153	145	136	127	110	101	84	58	41	23											
1	0														8	7	6	6	5	4	4						Shut-off 615 ft.	
	20														7	7	7	6	5	4	3							
	30														7	7	7	6	5	5	3	2						
	40														7	7	7	6	5	4	3							
	50														7	7	7	6	6	4	3							
	60														7	7	7	6	5	4								
	80														7	7	7	6	5	4								
Shut-off PSI		257	248	240	231	222	214	205	197	188	179	162	153	136	110	93	75	58	49									
1.5	0																										Shut-off 835 ft.	
	20																											
	30																											
	40																											
	50																											
	60																											
	80																											
Shut-off PSI		352	344	335	326	318	309	300	292	283	274	257	249	231	205	188	171	153	145	101	58	15						

Submersible Pumps

4" Series V Pumps - 5 GPM

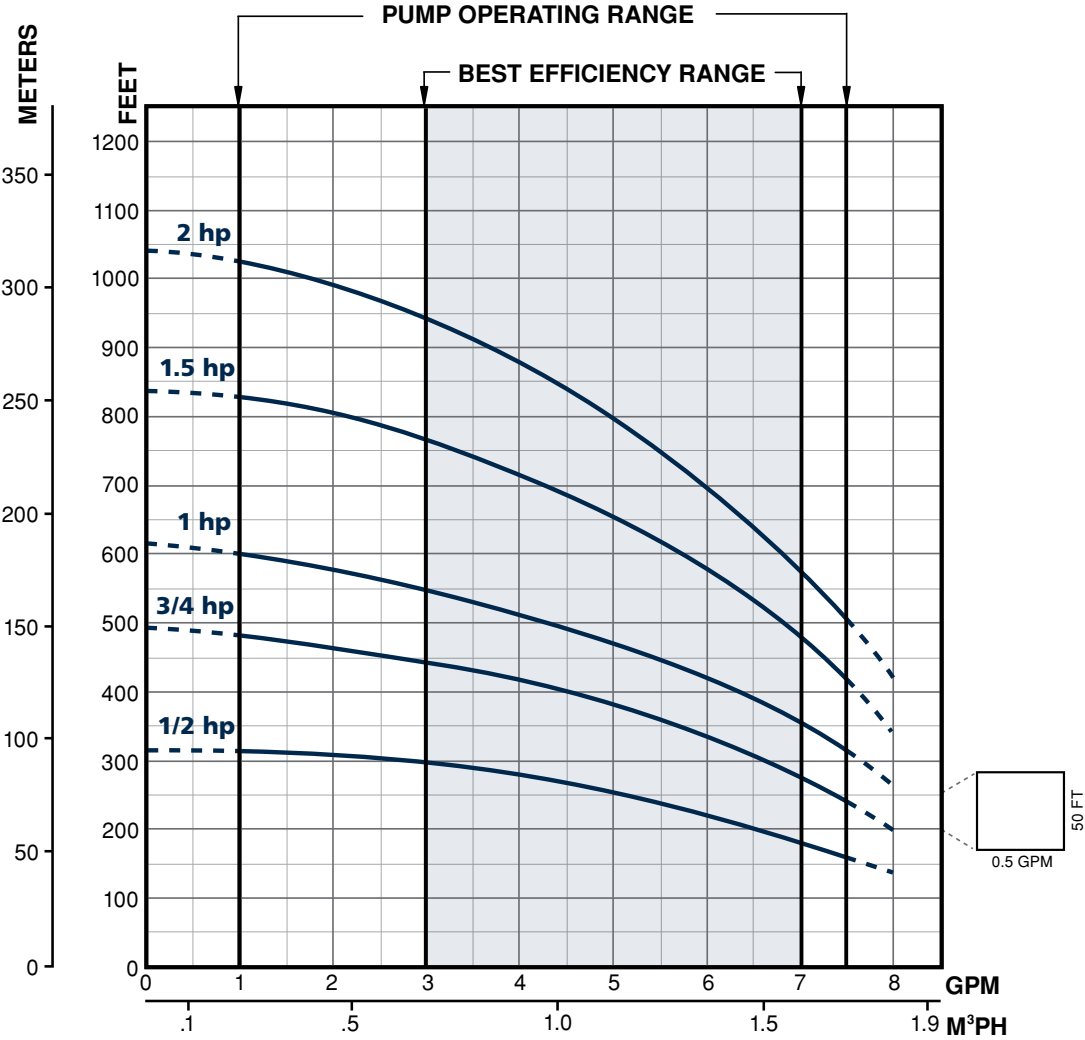

Capacities in U.S. Gallons per Minute

HP	PSI	Depth to Pumping Water Level, or Lift, in Feet. Shaded Areas Indicate Most Efficient Performance																								
		20	40	60	80	100	120	140	160	180	200	240	260	300	360	400	440	480	500		600	700	800	900	1000	
2	0																7	7	7	6	5	4	3		Shut-off 1040 ft.	
	20																7	7	7	6	5	4	2			
	30																7	7	7	6	6	5	3			
	40																7	7	7	6	6	6	5	3		
	50																7	7	7	6	6	5	4	3		
	60																7	7	7	6	6	5	4	3		
80																7	7	7	6	6	5	4	3			
Shut-off PSI		441	432	424	415	406	398	389	381	372	363	346	337	320	294	277	259	242	233	190	147	104	60			

Notes: 1. Performance shown does not include friction loss in the drop pipe. 2. All performance data is based on rated motor nameplate voltage.

Submersible Pumps

4" Series V Pumps - 7 GPM

Plastic	GPM	HP	Stg.	Volts	2-Wire			3-Wire			
					PMA Model	Order No.	Motor	PMA Model	Order No.	Motor	Control Box
					7	1/2	7	115	7FV05P4-2W115	95400705	2445049004S
	1/2	7	230	7FV05P4-2W230	95400710	2445059004S	7FV05P4-3W230	95400735	2145059004S	2801054915	
	3/4	10	230	7FV07P4-2W230	95400715	2445079004S	7FV07P4-3W230	95400740	2145079004S	2801074915	
	1	13	230	7FV1P4-2W230	95400720	2445089003S	7FV1P4-3W230	95400745	2145089003S	2801084915	
	1.5	18	230	7FV15P4-2W230	95400725	2443099004S	7FV15P4-3W230	95400750	2143099004S	2823008110	

Stainless Steel	GPM	HP	Stg.	Volts	2-Wire			3-Wire			
					PMA Model	Order No.	Motor	PMA Model	Order No.	Motor	Control Box
					7	1/2	7	115	7FV05S4-2W115	95420705	2445049004S
	1/2	7	230	7FV05S4-2W230	95420710	2445059004S	7FV05S4-3W230	95420735	2145059004S	2801054915	
	3/4	10	230	7FV07S4-2W230	95420715	2445079004S	7FV07S4-3W230	95420740	2145079004S	2801074915	
	1	13	230	7FV1S4-2W230	95420720	2445089003S	7FV1S4-3W230	95420745	2145089003S	2801084915	
	1.5	18	230	7FV15S4-2W230	95420725	2443099004S	7FV15S4-3W230	95420750	2143099004S	2823008110	

Stainless Steel - Pump End Assemblies Only				
GPM	HP	Stg.	PE Model	Order No.
7	1/2	7	7FV05S4-PE	95430700
	3/4	10	7FV07S4-PE	95430701
	1	13	7FV1S4-PE	95430702
	1.5	18	7FV15S4-PE	95430703
	2	24	7FV2S4-PE	95430704
	3	32	7FV3S4-PE	95430705

Plastic - Pump End Assemblies Only				
GPM	HP	Stg.	PE Model	Order No.
7	1/2	7	7FV05P4-PE	95410700
	3/4	10	7FV07P4-PE	95410701
	1	13	7FV1P4-PE	95410702
	1.5	18	7FV15P4-PE	95410703

Notes: Discharge is 1-1/4" NPT. Maximum diameter across cable guard is 3.90" on all models.

Capacities in U.S. Gallons per Minute

HP	PSI	Depth to Pumping Water Level, or Lift, in Feet. Shaded Areas Indicate Most Efficient Performance																								
		20	40	60	80	100	120	140	160	180	200	240	260	300	360	400	440	480	500	600		700	800	900	1000	
1/2	0																									Shut-off 300 ft.
	20																									
	30																									
	40																									
	50																									
	60																									
	80																									
Shut-off PSI		121	112	103	95	86	77	69	60	52	43	26	17													
3/4	0																									Shut-off 422 ft.
	20																									
	30																									
	40																									
	50																									
	60																									
	80																									
Shut-off PSI		174	165	156	148	139	130	122	113	104	96	78	70	52	26											
1	0																									Shut-off 544 ft.
	20																									
	30																									
	40																									
	50																									
	60																									
	80																									
Shut-off PSI		226	218	209	200	192	183	174	166	157	148	131	123	105	79	62	45	27	18							
1.5	0																									Shut-off 765 ft.
	20																									
	30																									
	40																									
	50																									
	60																									
	80																									
Shut-off PSI		322	313	305	296	287	279	270	261	253	244	227	218	201	175	158	140	123	114	71	28					
2	0																									Shut-off 995 ft.
	20																									
	30																									
	40																									
	50																									
	60																									
	80																									
Shut-off PSI		421	412	404	395	386	378	369	360	352	343	326	317	300	274	257	239	222	213	170	127	84	40			

Submersible Pumps

4" Series V Pumps - 7 GPM

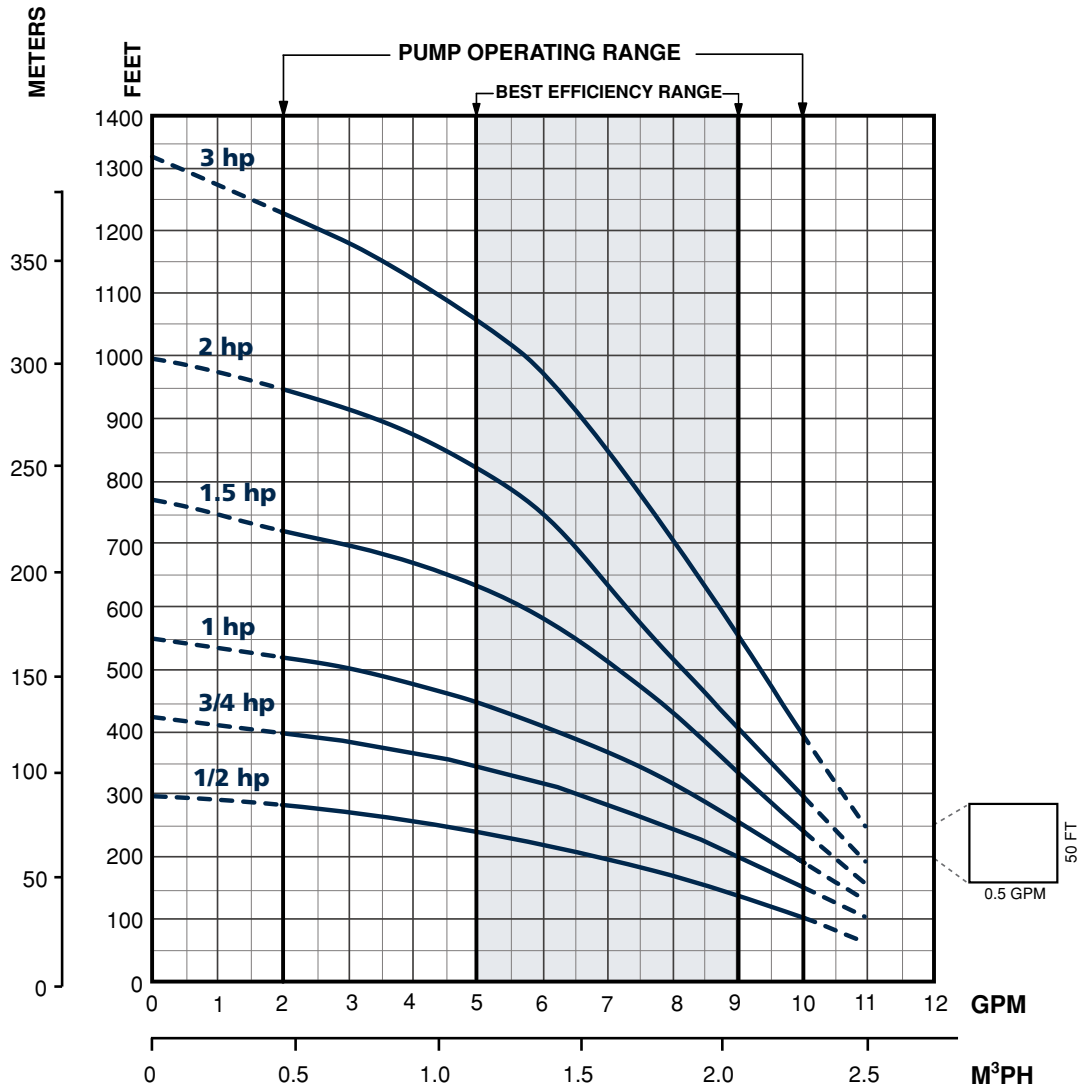

Capacities in U.S. Gallons per Minute

HP	PSI	Depth to Pumping Water Level, or Lift, in Feet. Shaded Areas Indicate Most Efficient Performance														Shut-off 1310 ft.									
		100	200	300	400	500	600	700	800	900	1000	1100	1200	1300	1400										
3	0			10	9	9	8	7	7	6	5	4	2												
	20		10	9	9	8	8	7	6	6	5	3													
	30		10	9	9	8	8	7	6	6	4	3													
	40		10	9	9	8	7	7	6	5	4														
	50	10	10	9	8	8	7	7	6	5	4														
	60	10	10	9	8	8	7	7	6	5	3														
	80	10	9	8	8	7	7	6	5	4	2														
Shut-off PSI		523	480	437	394	350	307	264	221	177	134	91	48												

Notes: 1. Performance shown does not include friction loss in the drop pipe. 2. All performance data is based on rated motor nameplate voltage.

Submersible Pumps

4" Series V Pumps - 10 GPM

Plastic	GPM	HP	Stg.	Volts	2-Wire			3-Wire			
					PMA Model	Order No.	Motor	PMA Model	Order No.	Motor	Control Box
					10	1/2	6	115	10FV05P4-2W115	95401005	2445049004S
	1/2	6	230	10FV05P4-2W230	95401010	2445059004S	10FV05P4-3W230	95401035	2145059004S	2801054915	
	3/4	8	230	10FV07P4-2W230	95401015	2445079004S	10FV07P4-3W230	95401040	2145079004S	2801074915	
	1	11	230	10FV1P4-2W230	95401020	2445089003S	10FV1P4-3W230	95401045	2145089003S	2801084915	
	1.5	15	230	10FV15P4-2W230	95401025	2443099004S	10FV15P4-3W230	95401050	2143099004S	2823008110	

Stainless Steel	GPM	HP	Stg.	Volts	2-Wire			3-Wire			
					PMA Model	Order No.	Motor	PMA Model	Order No.	Motor	Control Box
					10	1/2	6	115	10FV05S4-2W115	95421005	2445049004S
	1/2	6	230	10FV05S4-2W230	95421010	2445059004S	10FV05S4-3W230	95421035	2145059004S	2801054915	
	3/4	8	230	10FV07S4-2W230	95421015	2445079004S	10FV07S4-3W230	95421040	2145079004S	2801074915	
	1	11	230	10FV1S4-2W230	95421020	2445089003S	10FV1S4-3W230	95421045	2145089003S	2801084915	
	1.5	15	230	10FV15S4-2W230	95421025	2443099004S	10FV15S4-3W230	95421050	2143099004S	2823008110	

Stainless Steel - Pump End Assemblies Only				
GPM	HP	Stg.	PE Model	Order No.
10	1/2	6	10FV05S4-PE	95431000
	3/4	8	10FV07S4-PE	95431001
	1	11	10FV1S4-PE	95431002
	1.5	15	10FV15S4-PE	95431003
	2	18	10FV2S4-PE	95431004
	3	24	10FV3S4-PE	95431005
	5	39	10FV5S4-PE	95431006

Plastic - Pump End Assemblies Only				
GPM	HP	Stg.	PE Model	Order No.
10	1/2	6	10FV05P4-PE	95411000
	3/4	8	10FV07P4-PE	95411001
	1	11	10FV1P4-PE	95411002
	1.5	15	10FV15P4-PE	95411003

Notes: Discharge is 1-1/4" NPT. Maximum diameter across cable guard is 3.90" on all models.

Capacities in U.S. Gallons per Minute

HP	PSI	Depth to Pumping Water Level, or Lift, in Feet. Shaded Areas Indicate Most Efficient Performance																									
		20	40	60	80	100	120	140	160	180	200	240	260	300	360	400	440	480	500	600		700	800	900	1000		
1/2	0					14	13	12	11	10	9	7															Shut-off 244 ft.
	20	14	13	13	12	11	10	8	6	3																	
	30	13	13	12	11	10	8	6	3																		
	40	13	12	11	10	8	6	3																			
	50	12	11	9	8	5	3																				
	60	11	10	7	4																						
	80	8	6	4																							
Shut-off PSI		97	88	80	71	62	54	45	36	28	19																
3/4	0					14	13	13	12	11	10	7	8	4												Shut-off 338 ft.	
	20	14	14	13	12	12	11	10	9	8	6	4															
	30	14	14	13	12	12	11	10	9	8	7	3															
	40	14	13	12	12	11	10	9	8	7	6																
	50	13	12	11	11	10	9	8	7	5	3																
	60	12	11	11	10	9	8	6	5																		
	80	11	10	9	8	6	5																				
Shut-off PSI		137	129	120	111	103	94	85	77	68	59	42	34	16													
1	0					14	13	13	12	11	11	9	7	4												Shut-off 444 ft.	
	20					14	13	13	12	11	11	9	9	7	3												
	30					14	13	13	12	11	11	10	9	8	6												
	40					14	13	13	12	11	11	10	9	8	7	5											
	50					14	13	12	12	11	11	10	9	8	7	6											
	60					14	13	12	12	11	10	10	9	8	8	5	4										
	80					14	13	12	12	11	10	9	8	7	6	5											
Shut-off PSI		183	174	157	148	140	131	123	114	105	97	79	71	53	27	10											
1.5	0											14	13	13	12	12	10	9	9	8	7					Shut-off 615 ft.	
	20											14	13	13	12	12	11	11	9	8	7	6	5				
	30											14	13	13	12	12	11	11	10	8	8	6	5	4			
	40											14	13	13	12	12	11	10	10	8	7	6	4				
	50											14	13	13	12	12	11	10	10	9	8	6	5	3			
	60											14	13	13	12	12	11	11	11	10	9	7	6	4			
	80											13	13	13	12	12	11	11	10	9	9	8	6	3			
Shut-off PSI		257	248	240	231	222	214	205	197	188	179	162	153	136	110	93	75	41	32								
2	0												14	13	13	12	11	10	10	9	9	8	6		Shut-off 770 ft.		
	20												14	13	13	12	11	10	10	9	8	8	5				
	30												14	13	13	12	12	11	10	10	9	8	8				
	40												14	13	13	12	12	11	10	9	9	8	7				
	50												14	13	13	12	12	11	11	10	9	8	7				
	60												14	13	13	12	12	11	11	10	9	8	7				
	80												14	13	13	12	12	11	11	10	9	8	6				
Shut-off PSI		324	316	307	298	290	281	272	264	255	246	229	220	203	177	160	143	125	117	73							

Submersible Pumps

4" Series V Pumps - 10 GPM

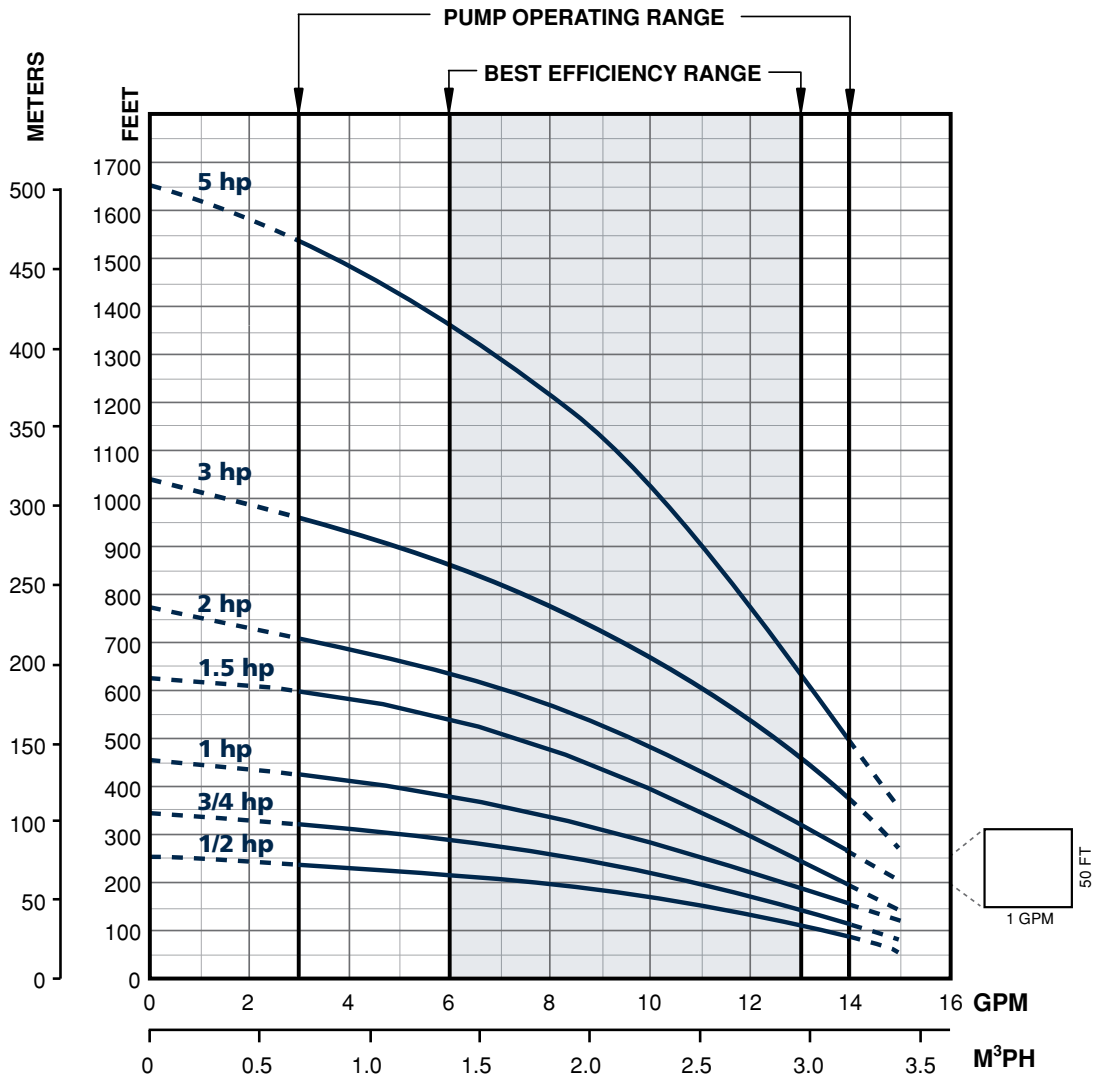

Capacities in U.S. Gallons per Minute

HP	PSI	Depth to Pumping Water Level, or Lift, in Feet. Shaded Areas Indicate Most Efficient Performance																							
		20	40	60	80	100	120	140	160	180	200	240	260	300	360	400	440	480	500		600	700	800	900	1000
3	0														14	13	13	12	12	11	9	7	5		Shut-off 1034 ft.
	20													14	13	13	12	12	12	10	8	6	3		
	30												14	14	13	13	12	12	11	10	8	5			
	40											14	14	14	13	12	12	11	11	9	7	4			
	50										14	14	14	13	12	12	11	11	11	9	7	4			
	60									14	14	14	13	13	12	12	11	11	10	9	6	3			
	80								14	14	13	13	13	12	12	11	11	10	10	8	5				
Shut-off PSI		438	430	421	413	404	395	387	378	369	361	343	335	317	291	274	257	240	231	188	144	101	58		
HP	PSI	100	200	300	400	500	600	700	800	900	1000	1100	1200	1300	1400										Shut-off 1648 ft.
5	0				14	13	13	12	11	11	10	9	8	6	5										
	20				14	13	12	12	11	10	9	8	7	6	4										
	30				14	13	12	12	11	10	9	8	7	5	4										
	40				14	13	12	11	11	10	9	8	7	5	3										
	50			14	13	13	12	11	10	9	9	7	6	5	3										
	60			14	13	13	12	11	10	9	8	7	6	4											
	80		14	14	13	12	11	11	10	9	8	7	5	3											
Shut-off PSI		670	626	583	540	497	453	410	367	324	280	237	194	151	107										

Notes: 1. Performance shown does not include friction loss in the drop pipe. 2. All performance data is based on rated motor nameplate voltage.

Submersible Pumps

4" Series V Pumps - 15 GPM

Plastic	GPM	HP	Stg.	Volts	2-Wire			3-Wire			
					PMA Model	Order No.	Motor	PMA Model	Order No.	Motor	Control Box
					15	1/2	4	115	15FV05P4-2W115	95401505	2445049004S
	1/2	4	230	15FV05P4-2W230	95401510	2445059004S	15FV05P4-3W230	95401535	2145059004S	2801054915	
	3/4	6	230	15FV07P4-2W230	95401515	2445079004S	15FV07P4-3W230	95401540	2145079004S	2801074915	
	1	8	230	15FV1P4-2W230	95401520	2445089003S	15FV1P4-3W230	95401545	2145089003S	2801084915	
	1.5	11	230	15FV15P4-2W230	95401525	2443099004S	15FV15P4-3W230	95401550	2143099004S	2823008110	

Stainless Steel	GPM	HP	Stg.	Volts	2-Wire			3-Wire			
					PMA Model	Order No.	Motor	PMA Model	Order No.	Motor	Control Box
					15	1/2	4	115	15FV05S4-2W115	95421505	2445049004S
	1/2	4	230	15FV05S4-2W230	95421510	2445059004S	15FV05S4-3W230	95421535	2145059004S	2801054915	
	3/4	6	230	15FV07S4-2W230	95421515	2445079004S	15FV07S4-3W230	95421540	2145079004S	2801074915	
	1	8	230	15FV1S4-2W230	95421520	2445089003S	15FV1S4-3W230	95421545	2145089003S	2801084915	
	1.5	11	230	15FV15S4-2W230	95421525	2443099004S	15FV15S4-3W230	95421550	2143099004S	2823008110	

Stainless Steel - Pump End Assemblies Only				
GPM	HP	Stg.	PE Model	Order No.
15	1/2	4	15FV05S4-PE	95431500
	3/4	6	15FV07S4-PE	95431501
	1	8	15FV1S4-PE	95431502
	1.5	11	15FV15S4-PE	95431503
	2	14	15FV2S4-PE	95431504
	3	19	15FV3S4-PE	95431505
	5	31	15FV5S4-PE	95431506

Plastic - Pump End Assemblies Only				
GPM	HP	Stg.	PE Model	Order No.
15	1/2	4	15FV05P4-PE	95411500
	3/4	6	15FV07P4-PE	95411501
	1	8	15FV1P4-PE	95411502
	1.5	11	15FV15P4-PE	95411503

Notes: Discharge is 1-1/4" NPT. Maximum diameter across cable guard is 3.90" on all models.

Capacities in U.S. Gallons per Minute

HP	PSI	Depth to Pumping Water Level, or Lift, in Feet. Shaded Areas Indicate Most Efficient Performance																								
		20	40	60	80	100	120	140	160	180	200	240	260	300	360	400	440	480	500	600	700	800	900	1000	1100	1200
1/2	0			20	18	16	13	9	4																	
	20	19	17	15	12	8																				
	30	17	14	11	7																					
	40	14	11	6																						
	50	10	5																							
	60	4																								
	80																									
Shut-off PSI	65	56	48	39	30	22	13	4																		
3/4	0			20	19	18	16	15	13	11																
	20		20	19	17	16	14	12	10	7																
	30	20	18	17	16	14	12	10	6																	
	40	18	17	15	14	12	9	6																		
	50	17	15	13	11	9	5																			
	60	15	13	11	8	4																				
	80	10	7																							
Shut-off PSI	103	94	85	77	68	59	51	42	33	25																
1	0			20	19	18	17	16	15	13	11	7														
	20		20	19	18	17	16	15	14	12	9	6														
	30	20	20	19	18	17	16	15	14	12	10	6														
	40	19	19	18	17	16	15	13	12	10	8															
	50	18	18	17	16	14	13	12	10	8	5															
	60	17	16	15	14	13	11	10	7	4																
	80	15	14	12	11	9	6																			
Shut-off PSI	140	131	123	114	105	97	88	79	71	62	45	36	19													
1.5	0			20	20	19	19	18	17	16	14	11	8	4												
	20			20	20	19	18	18	17	16	15	14	12	7												
	30			20	20	19	18	18	17	16	15	14	13	10	5											
	40		20	19	19	18	18	17	16	15	15	13	11	9												
	50	20	19	19	18	17	17	16	15	14	13	11	10	7												
	60	19	19	18	17	17	16	15	14	13	12	10	8	4												
	80	18	17	16	16	15	14	13	12	11	9	6														
Shut-off PSI	193	185	176	167	159	150	141	133	124	115	98	89	72	46	29	11										
2	0			20	20	19	19	18	18	17	15	13	12	10	8											
	20			20	20	19	19	18	17	17	15	13	11	9	7	5										
	30			20	20	19	19	18	18	16	16	14	12	10	8	5										
	40			20	20	20	19	19	18	17	16	16	14	11	9	6										
	50		20	20	19	19	19	18	17	17	16	15	14	13	10	7	4									
	60	20	20	19	19	18	18	17	17	16	16	14	13	12	9	6										
	80	19	19	18	18	17	17	16	15	15	14	12	11	9	5											
Shut-off PSI	249	240	231	223	214	205	197	188	179	171	153	145	127	101	84	67	49	41								

Submersible Pumps

4" Series V Pumps - 15 GPM

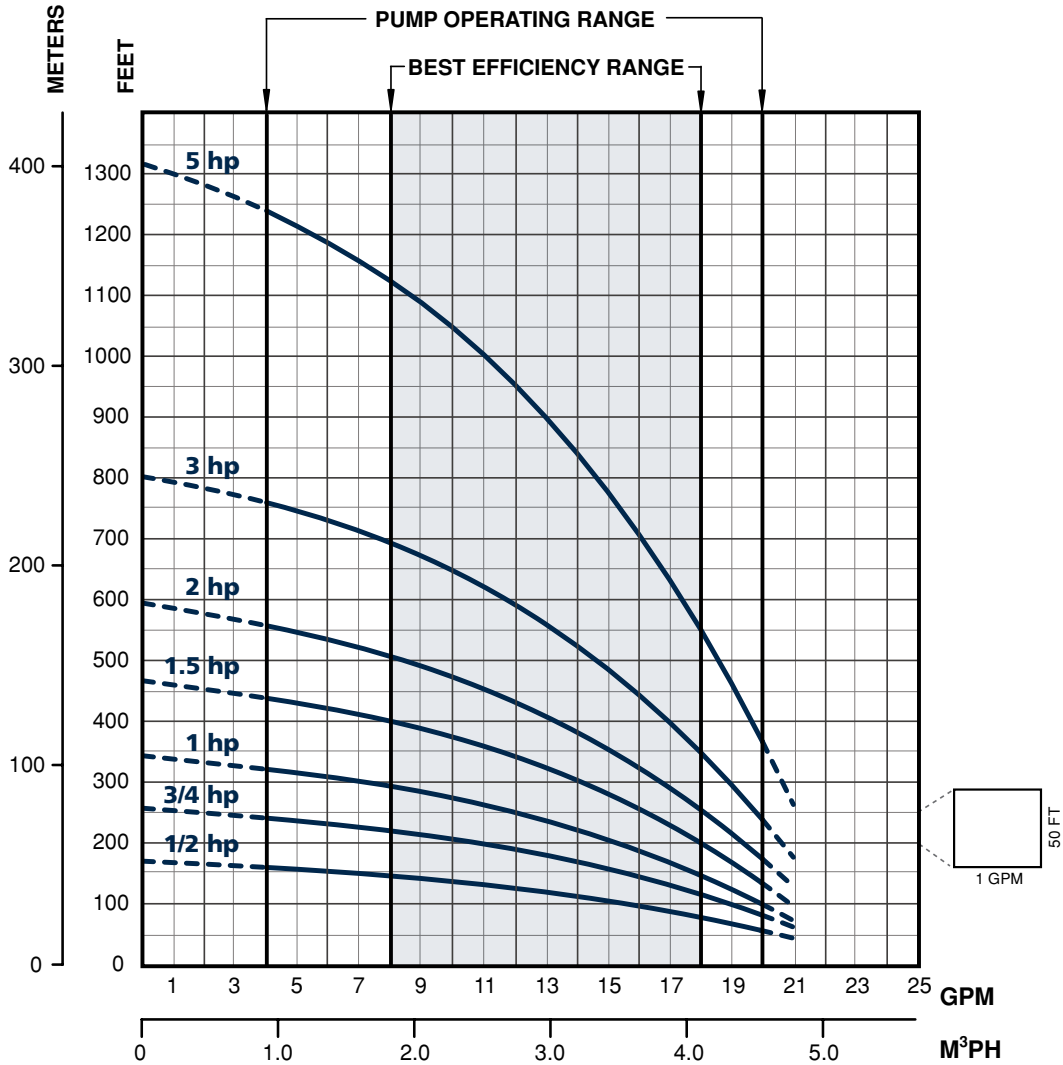

Capacities in U.S. Gallons per Minute

HP	PSI	Depth to Pumping Water Level, or Lift, in Feet. Shaded Areas Indicate Most Efficient Performance																		Shut-off									
		20	40	60	80	100	120	140	160	180	200	240	260	300	360	400	440	480	500		600	700	800	900	1000	1100	1200		
3	0																										802 ft.		
	20								20	20	20	19	19	18	17	16	15	14	13	10	8								
	30								20	20	20	19	19	18	18	16	15	14	13	9									
	40								20	20	20	19	19	18	18	17	16	15	14	13	12	8							
	50						20	20	20	20	19	19	19	18	18	17	15	14	13	12	11	7							
	60						20	20	20	19	19	19	18	17	17	16	15	14	12	11	10	5							
	80	20	20	20	20	19	19	19	18	18	17	16	16	15	13	12	11	9	8										
Shut-off PSI		339	330	321	313	304	295	287	278	269	261	243	235	217	191	174	157	139	131	87	44								
5	0															20	20	19	19	19	17	16	15	13	11	9	6	1316 ft.	
	20															20	20	19	19	18	18	17	15	14	12	10	7		4
	30															20	20	19	19	18	18	17	15	14	12	9	7		
	40															20	20	19	19	18	18	16	15	13	11	9	6		
	50															20	20	20	19	19	18	17	16	14	13	11	8		5
	60															20	20	20	19	19	18	17	16	14	12	10	8		4
	80									20	20	20	20	19	19	18	18	17	17	16	15	13	11	9	6				
Shut-off PSI		561	553	544	535	527	518	509	501	492	483	466	457	440	414	397	379	362	353	310	267	224	180	137	94	50			

Notes: 1. Performance shown does not include friction loss in the drop pipe. 2. All performance data is based on rated motor nameplate voltage.

Submersible Pumps

4" Series V Pumps - 20 GPM

Plastic	GPM	HP	Stg.	Volts	2-Wire			3-Wire			
					PMA Model	Order No.	Motor	PMA Model	Order No.	Motor	Control Box
					20	3/4	5	230	20FV07P4-2W230	95402015	2445079004S
	1	7	230	20FV1P4-2W230	95402020	2445089003S	20FV1P4-3W230	95402045	2145089003S	2801084915	
	1.5	10	230	20FV15P4-2W230	95402025	2443099004S	20FV15P4-3W230	95402050	2143099004S	2823008110	

Stainless Steel	GPM	HP	Stg.	Volts	2-Wire			3-Wire			
					PMA Model	Order No.	Motor	PMA Model	Order No.	Motor	Control Box
					20	3/4	5	230	20FV07S4-2W230	95422015	2445079004S
	1	7	230	20FV1S4-2W230	95422020	2445089003S	20FV1S4-3W230	95422045	2145089003S	2801084915	
	1.5	10	230	20FV15S4-2W230	95422025	2443099004S	20FV15S4-3W230	95422050	2143099004S	2823008110	

Stainless Steel - Pump End Assemblies Only				
GPM	HP	Stg.	PE Model	Order No.
20	3/4	5	20FV07S4-PE	95432001
	1	7	20FV1S4-PE	95432002
	1.5	10	20FV15S4-PE	95432003
	2	12	20FV2S4-PE	95432004
	3	16	20FV3S4-PE	95432005
	5	26	20FV5S4-PE	95432006

Plastic - Pump End Assemblies Only				
GPM	HP	Stg.	PE Model	Order No.
20	3/4	5	20FV07P4-PE	95412001
	1	7	20FV1P4-PE	95412002
	1.5	10	20FV15P4-PE	95412003

Notes: Discharge is 1-1/4" NPT. Maximum diameter across cable guard is 3.90" on all models.

Capacities in U.S. Gallons per Minute

HP	PSI	Depth to Pumping Water Level, or Lift, in Feet. Shaded Areas Indicate Most Efficient Performance																											
		20	40	60	80	100	120	140	160	180	200	240	260	300	360	400	440	480	500		600	700	800	900	1000				
3/4	0						24	22	21	18	14															Shut-off 190 ft			
	20																												
	30	23	21	19	17	11																							
	40	21	19	17	10																								
	50	19	16	10																									
	60	14																											
Shut-off PSI		74	65	56	48	39	30	22	13																				
1	0						26	25	23	20	18	11														Shut-off 251 ft			
	20																												
	30			27	26	24	22	20	18	15	8																		
	40	27	25	23	21	19	17	13																					
	50	25	23	21	19	16	12																						
	60	23	21	18	16	11																							
Shut-off PSI		100	91	83	74	66	57	48	40	31	22	5																	
1.5	0								27	26	24	22	20	17	6											Shut-off 379 ft			
	20																												
	30								27	25	24	22	21	20	16	13													
	40									26	25	23	22	21	19	18	13	8											
	50			27	26	25	23	22	21	19	17	15	7																
	60	27	26	24	23	22	20	19	17	15	11																		
Shut-off PSI		156	147	138	130	121	112	104	95	86	78	60	52	34	8														
2	0												24	23	20	16	12									Shut-off 453 ft			
	20													24	21	20	17	12											
	30														24	23	22	20	19	16									
	40															24	23	22	21	19	17	14							
	50																24	23	22	20	19	16	14	10					
	60																	24	23	22	20	19	18	14	12				
Shut-off PSI		187	179	170	161	153	144	135	127	118	110	92	84	66	40	23													
3	0															24	22	20	18	16	14					Shut-off 601 ft			
	20																24	23	20	17	15	12	10						
	30																	24	23	21	18	16	13	10					
	40																		24	23	22	20	17	14	11				
	50																			24	24	22	21	19	16		13		
	60																				24	24	23	21	20		18	14	10
Shut-off PSI		251	242	234	225	216	208	199	190	182	173	156	147	130	104	87	69	52	43										

Submersible Pumps

4" Series V Pumps - 20 GPM

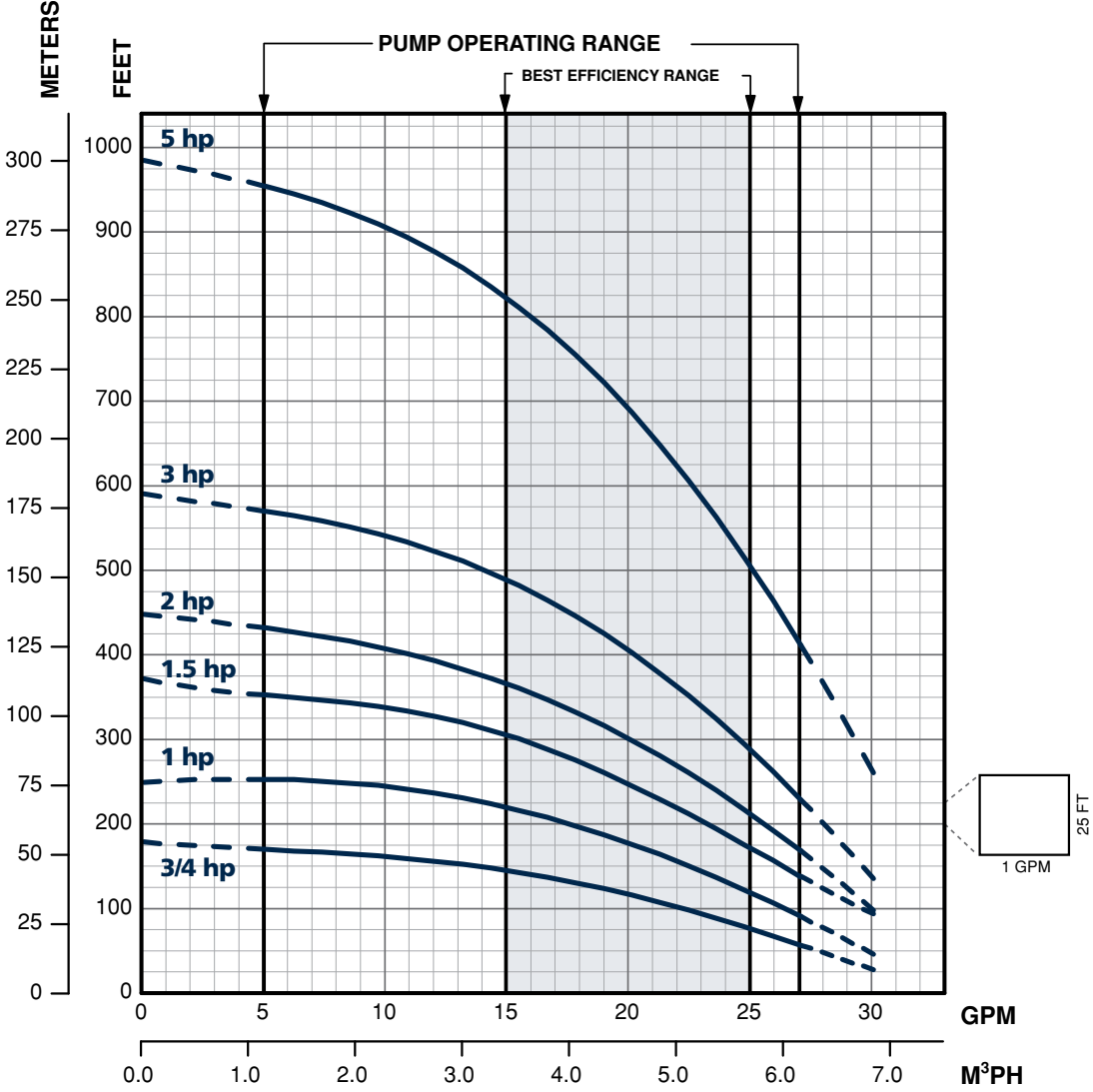

Capacities in U.S. Gallons per Minute

HP	PSI	Depth to Pumping Water Level, or Lift, in Feet. Shaded Areas Indicate Most Efficient Performance																						
		20	40	60	80	100	120	140	160	180	200	240	260	300	360	400	440	480	500	600	700	800	900	1000
5	0																		24	23	20	16		
	20																		24	21	18	13		
	30																	24	23	20	17	11		
	40																	24	23	20	16	10		
	50																	24	22	22	17	15		
	60																	24	23	21	18	14		
	80																	24	23	22	21	20	16	10
Shut-off PSI		416	408	399	390	382	373	364	356	347	339	321	313	295	269	252	235	217	209	165	122	79		

Notes: 1. Performance shown does not include friction loss in the drop pipe. 2. All performance data is based on rated motor nameplate voltage.

Submersible Pumps

4" Series V Pumps - 25 GPM

Material	GPM	HP	Stg.	Volts	2-Wire			3-Wire			
					PMA Model	Order No.	Motor	PMA Model	Order No.	Motor	Control Box
					25	1 1.5	6 8	230 230	25FV1P4-2W230 25FV15P4-2W230	95402520 95402525	2445089003S 2443099004S

Material	GPM	HP	Stg.	Volts	2-Wire			3-Wire			
					PMA Model	Order No.	Motor	PMA Model	Order No.	Motor	Control Box
					25	1 1.5	6 8	230 230	25FV1S4-2W230 25FV15S4-2W230	95422520 95422525	2445089003S 2443099004S

Stainless Steel - Pump End Assemblies Only				
GPM	HP	Stg.	PE Model	Order No.
25	1	6	25FV1S4-PE	95432501
	1.5	8	25FV15S4-PE	95432502
	2	10	25FV2S4-PE	95432503
	3	14	25FV3S4-PE	95432504
	5	23	25FV5S4-PE	95432505

Plastic - Pump End Assemblies Only				
GPM	HP	Stg.	PE Model	Order No.
25	1	6	25FV1P4-PE	95412501
	1.5	8	25FV15P4-PE	95412502

Notes: Discharge is 1-1/4" NPT. Maximum diameter across cable guard is 3.90" on all models.

Capacities in U.S. Gallons per Minute

HP	PSI	Depth to Pumping Water Level, or Lift, in Feet. Shaded Areas Indicate Most Efficient Performance																							
		20	40	60	80	100	120	140	160	180	200	240	260	300	360	400	440	480	500	600	700		800	900	1000
1	0			35	33	31	28	26	24	21	17														Shut-off 222 ft
	20		32	30	28	25	22	18	15																
	30	32	29	27	25	22	19																		
	40	29	27	25	22	19																			
	50	26	24	21	16																				
	60	24	21	17																					
Shut-off PSI		87	79	70	61	53	44	35	27	18	10														
1.5	0					33	31	29	27	25	21	19												Shut-off 297 ft	
	20				32	30	28	26	24	22	19														
	30			32	30	28	26	24	22	19	16														
	40	33	32	29	27	25	23	21	19	15															
	50	32	29	27	25	23	21	18																	
	60	29	27	25	23	20	18																		
Shut-off PSI		120	111	103	94	85	77	68	59	51	42	25	16												
2	0					33	32	30	28	25	24	20												Shut-off 375 ft	
	20				34	33	31	29	28	26	25	21	20												
	30			34	33	31	29	28	26	24	23	19	17												
	40		34	33	31	29	28	26	24	23	21	17													
	50	33	32	30	29	27	26	24	22	20	18														
	60	32	30	28	27	26	24	22	20	18															
Shut-off PSI		154	145	136	128	119	110	102	93	84	76	58	50	32											
3	0							33	32	30	29	28	24	22	19	15								Shut-off 519 ft	
	20					33	32	32	31	30	28	27	25	22	19										
	30					33	32	32	31	30	29	27	26	24	20										
	40				33	32	32	31	30	29	28	26	25	22	18										
	50			33	32	31	31	30	29	28	27	24	23	21	15										
	60		33	32	31	31	30	29	28	26	25	23	22	19											
Shut-off PSI		216	207	199	190	181	173	164	155	147	138	121	112	95	69	52	34	17							
5	0												33	32	31	30	28	28	24	20				Shut-off 833 ft	
	20												33	32	30	30	28	27	26	22	17				
	30												33	33	31	30	28	27	26	25	21	15			
	40												33	32	32	31	29	28	27	25	24	20			
	50												33	33	32	31	30	28	27	25	24	23	19		
	60												33	33	32	31	31	30	28	26	25	23	22		18
Shut-off PSI		352	343	326	317	309	300	291	283	274	257	248	231	205	187	170	153	144	101	58					

Submersible Pumps

4" Series V Pumps - 25 GPM

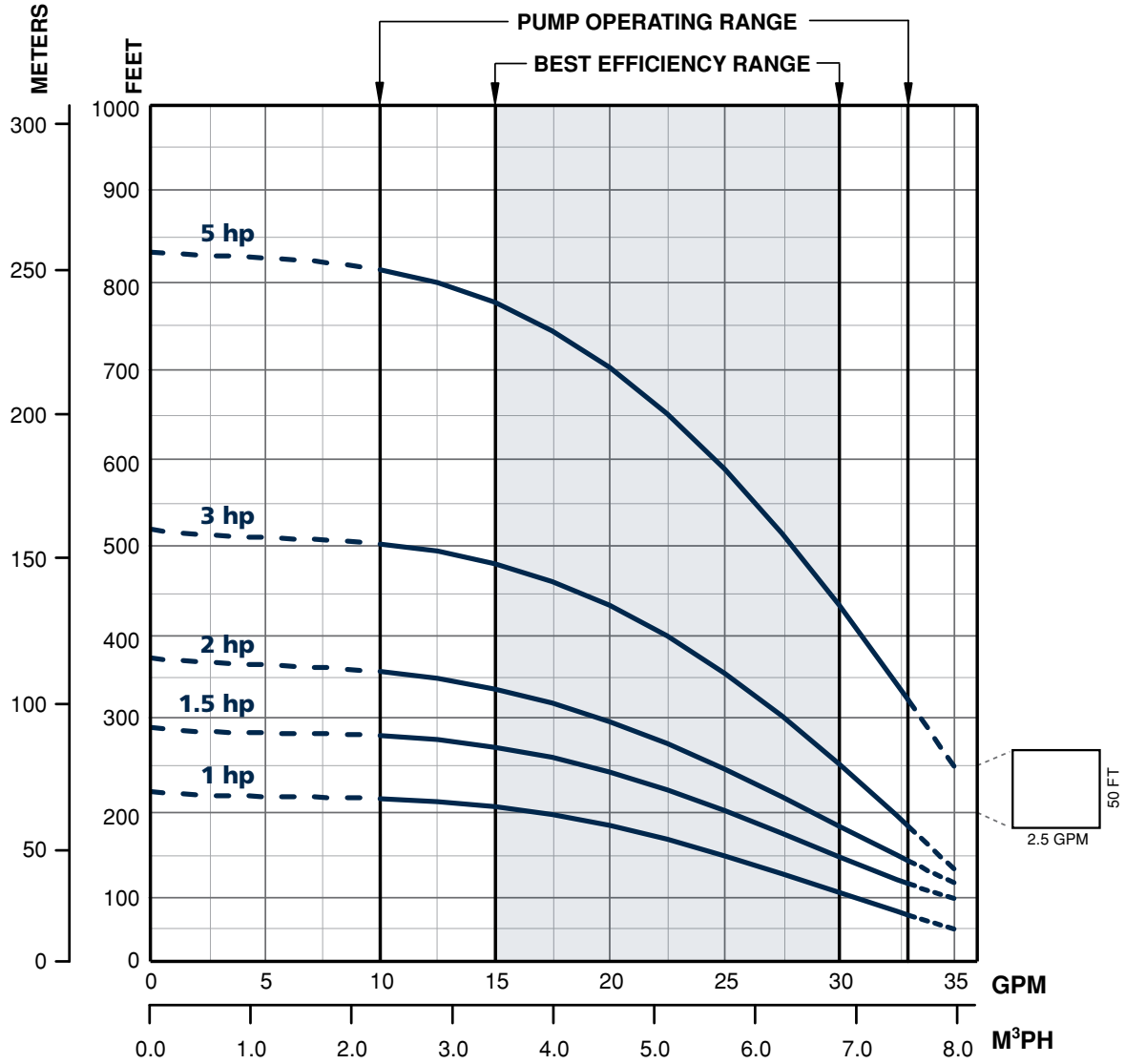

Submersible Pumps

4" Series V Pumps - Dimensions

Stainless Steel

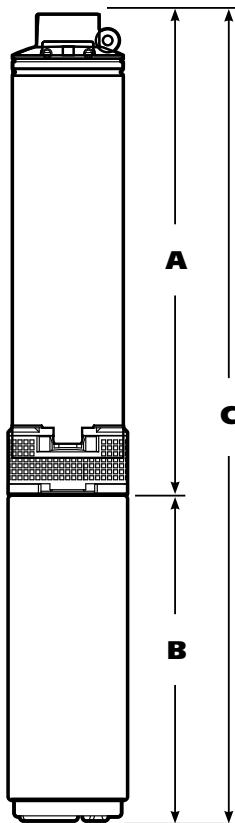

Thermoplastic

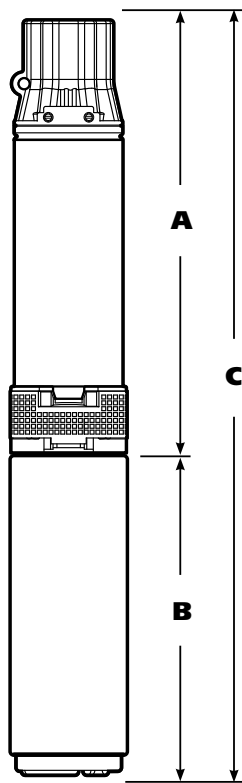

Notes: All lengths are in inches
 All weights are in pounds
 Maximum diameter with cable guard is 3.90"

Plastic with 2-Wire Motors

GPM	HP	Stages	A	B	C	PE Wt.	PMA Wt.
5	1/2	8	14.29	9.51	23.80	8	26
	3/4	12	17.80	10.64	28.44	9	30
	1	15	20.28	11.73	32.01	10	34
	1.5	21	25.23	15.10	40.33	12	43
7	1/2	7	13.47	9.51	22.98	7	25
	3/4	10	15.95	10.64	26.59	8	29
	1	13	18.62	11.73	30.35	10	34
	1.5	18	22.77	15.10	37.87	11	42
10	1/2	6	13.13	9.51	22.64	7	25
	3/4	8	14.95	10.64	25.59	8	29
	1	11	17.88	11.73	29.61	9	33
	1.5	15	21.52	15.10	36.62	10	41
15	1/2	4	11.51	9.51	21.02	6	24
	3/4	6	13.13	10.64	23.77	7	28
	1	8	14.95	11.73	26.68	8	32
	1.5	11	17.68	15.10	32.78	9	40
20	3/4	5	13.79	10.64	24.43	6	28
	1	7	16.23	11.73	27.96	7	31
	1.5	10	19.91	15.10	35.01	8	39
25	1	6	15.01	11.73	26.74	7	31
	1.5	8	17.46	15.10	32.56	8	39

Plastic with 3-Wire Motors

GPM	HP	Stages	A	B	C	PE Wt.	PMA Wt.
5	1/2	8	14.29	9.51	23.80	8	27
	3/4	12	17.80	10.64	28.44	9	30
	1	15	20.28	11.73	32.01	10	34
	1.5	21	25.23	13.60	38.83	12	40
7	1/2	7	13.47	9.51	22.98	7	26
	3/4	10	15.95	10.64	26.59	8	29
	1	13	18.62	11.73	30.35	10	34
	1.5	18	22.77	13.60	36.37	11	39
10	1/2	6	13.13	9.51	22.64	7	26
	3/4	8	14.95	10.64	25.59	8	29
	1	11	17.88	11.73	29.61	9	33
	1.5	15	21.52	13.60	35.12	10	38
15	1/2	4	11.51	9.51	21.02	6	25
	3/4	6	13.13	10.64	23.77	7	28
	1	8	14.95	11.73	26.68	8	32
	1.5	11	17.68	13.60	31.28	9	37
20	3/4	5	13.79	10.64	24.43	6	28
	1	7	16.23	11.73	27.96	7	31
	1.5	10	19.91	13.60	33.51	8	36
25	1	6	15.01	11.73	26.74	7	31
	1.5	8	17.46	13.60	31.06	8	36

Notes: PE - Pump end only PMA - Pump and motor assembly

Submersible Pumps

4" Series V Pumps - Dimensions

Stainless Steel with 2-Wire Motors

GPM	HP	Stages	A	B	C	PE Wt.	PMA Wt.
5	1/2	8	14.31	9.51	23.82	10	28
	3/4	12	17.62	10.64	28.26	12	33
	1	15	20.10	11.73	31.83	14	38
	1.5	21	25.06	15.10	40.16	17	48
7	1/2	7	13.49	9.51	23.00	9	27
	3/4	10	15.97	10.64	26.61	11	32
	1	13	18.45	11.73	30.18	13	37
	1.5	18	22.59	15.10	37.69	15	46
10	1/2	6	13.15	9.51	22.66	9	27
	3/4	8	14.97	10.64	25.61	10	31
	1	11	17.70	11.73	29.43	11	35
	1.5	15	21.34	15.10	36.44	14	45
15	1/2	4	11.33	9.51	20.84	7	25
	3/4	6	13.15	10.64	23.79	9	30
	1	8	14.97	11.73	26.70	10	34
	1.5	11	17.70	15.10	32.80	11	42
20	3/4	5	13.84	10.64	24.48	8	29
	1	7	16.30	11.73	28.03	9	33
	1.5	10	19.98	15.10	33.85	11	42
25	1	6	15.07	11.73	26.80	9	33
	1.5	8	17.52	15.10	32.62	10	41

Notes: PE - Pump end only
PMA - Pump and motor assembly

Stainless Steel with 3-Wire Motors

GPM	HP	Stages	A	B	C	PE Wt.	PMA Wt.
5	1/2	8	14.31	9.51	23.82	10	29
	3/4	12	17.62	10.64	28.26	12	33
	1	15	20.10	11.73	31.83	14	38
	1.5	21	25.06	13.60	38.66	17	45
	2	26	31.48	15.10	46.58	20	N/A
7	1/2	7	13.49	9.51	23.00	9	28
	3/4	10	15.97	10.64	26.61	11	32
	1	13	18.45	11.73	30.18	13	37
	1.5	18	22.59	13.60	36.19	15	43
	2	24	27.74	15.10	42.84	19	N/A
10	3	32	36.44	19.04	55.48	23	N/A
	1/2	6	13.15	9.51	22.66	9	28
	3/4	8	14.97	10.64	25.61	10	31
	1	11	17.70	11.73	29.43	11	35
	1.5	15	21.34	13.60	34.94	14	42
15	2	18	26.15	15.10	41.25	15	N/A
	3	24	31.81	19.04	50.85	19	N/A
	5	39	45.45	28.19	74.64	27	N/A
	1/2	4	11.33	9.51	20.84	7	26
	3/4	6	13.15	10.64	23.79	9	30
15	1	8	14.97	11.73	26.70	10	34
	1.5	11	17.70	13.60	31.30	11	39
	2	14	20.43	15.10	35.53	13	N/A
	3	19	27.09	19.04	46.13	16	N/A
	5	31	38.30	29.19	67.49	23	N/A
20	3/4	5	13.84	10.64	24.48	8	29
	1	7	16.30	11.73	28.03	9	33
	1.5	10	19.98	13.60	32.35	11	39
	2	12	22.45	15.10	37.55	12	N/A
	3	16	27.56	19.04	46.60	14	N/A
25	5	26	41.92	29.19	71.11	20	N/A
	1	6	15.07	11.73	26.80	9	33
	1.5	8	17.52	13.60	31.12	10	38
	2	10	19.98	15.10	35.08	11	N/A
	3	14	24.90	19.04	43.94	13	N/A
25	5	23	38.24	29.19	67.43	18	N/A

Submersible Pumps

4" High Capacity Pump - Features



FPS4400

Features:

- 4 performance ranges - 35, 45, 60, and 90 gpm.
- Stainless steel discharge head and motor bracket.
- High flow impellers and stages are glass-filled Noryl® for maximum efficiency.
- Ceramic shaft sleeve and rubber discharge bearing eliminates sand wear.
- Intermediate bearing for increased shaft stability.
- Floating eye and hub seals for improved performance and efficiency.
- Stainless steel hex pump shaft, shell, and shaft coupling.
- High capacity upthrust assembly for protection during start-up and operation (45, 60, and 90 gpm models).
- Powered by Franklin's corrosion-resistant 4" submersible motors.
- 2" NPT discharge.
- Check valve must be ordered separately. See page 76.

Noryl® is a registered trademark of G.E.



UL 778
CSA 108
NSF/ANSI 372
NSF/ANSI 61 (Pump end only)

Submersible Pumps

4" High Capacity Pumps - Ordering Information

1 - 10 HP 4" Pump Ends						
GPM	HP	Stages	Ordering Info.		Dimensions	Wt.
			Model No.	Order No.	Pump End Only	
35	1	6	35FA1S4-PE	93613506	15.00	9
	1.5	8	35FA15S4-PE	93613508	17.50	10
	2	10	35FA2S4-PE	93613510	20.00	11
	3	14	35FA3S4-PE	93613514	25.00	13
	5	22	35FA5S4-PE	93613522	35.00	17
	7.5	34	35FA7S4-PE	93613534	52.17	25
	10	42	35FA10S4-PE	93613542	62.23	31
45	1.5	6	45FA15S4-PE	93614506	21.00	15
	2	8	45FA2S4-PE	93614508	25.50	16
	3	11	45FA3S4-PE	93614511	32.25	19
	5	18	45FA5S4-PE	93614518	47.75	25
	7.5	26	45FA7S4-PE	93614526	65.25	33
	10	31	45FA10S4-PE	93614531	78.30	38
60	2	6	60FA2S4-PE	93616006	21.00	15
	3	8	60FA3S4-PE	93616008	25.50	17
	5	13	60FA5S4-PE	93616013	36.75	21
	7.5	17	60FA7S4-PE	93616017	45.25	25
	10	24	60FA10S4-PE	93616024	61.00	31
90	2	5	90FA2S4-PE	93619005	22.56	15
	3	7	90FA3S4-PE	93619007	28.56	17
	5	12	90FA5S4-PE	93619012	43.56	21
	7.5	19	90FA7S4-PE	93619019	64.50	27
	10	24	90FA10S4-PE	93619020	79.25	31

Notes: All dimensions are in inches. Discharge is 2" NPT. Maximum diameter across cable guard is 3.90" on all models. Weight in pounds.

1 - 1.5 HP Single-Phase Units									
GPM	HP	Stages	Volts	2-Wire			3-Wire		
				Model No.	Order No.	Wt.	Model No.	Order No.	Wt.
35	1	6	230	35FA1S4-2W230	93613606	33	35FA1S4-3W230	93613706	33
	1.5	8	230	35FA15S4-2W230	93613608	41	35FA15S4-3W230	93613708	39
45	1.5	6	230	45FA15S4-2W230	93614606	46	45FA15S4-3W230	93614706	44

Notes: All listed above have 2" NPT discharge. Order check valve separately.
Pump and motor will be individually cartoned and require assembly.
Weight in pounds.

Submersible Pumps

4" High Capacity Pumps - 35 GPM

Capacities in U.S. Gallons per Minute

HP	PSI	Depth to Pumping Water Level, or Lift, in Feet. Shaded Areas Indicate Most Efficient Performance																			
		20	40	60	80	100	120	140	160	180	200	250	300	350	400	450	500	550	600		
1	0			44	40	34	28	22	13												
	10		43	39	33	27	21	11													
	20	43	38	32	26	20															
	30	37	31	26	19																
	40	30	25	18																	
	50	24	16																		
	60	14																			
	70																				
	80																				
Shut-off PSI		65	57	48	39	31	22	13	5												
1.5	0			45	43	40	36	31	27	23	18										
	10		45	42	39	35	31	27	23	16											
	20	45	42	38	34	30	26	22	15												
	30	41	38	34	30	26	21	14													
	40	37	33	29	25	20	12														
	50	32	29	24	19	10															
	60	28	24	18																	
	70	23	17																		
	80	16																			
Shut-off PSI		89	81	72	63	55	46	37	29	20	11										
2	0			45	43	41	38	34	31	28	19										
	10			45	43	40	37	34	31	27	24	11									
	20		45	43	40	37	33	30	27	24	20										
	30	44	42	39	36	33	30	26	23	19	12										
	40	42	39	36	32	29	26	22	18	11											
	50	39	35	32	29	25	22	17	10												
	60	35	31	28	25	21	16														
	70	31	28	24	21	15															
	80	27	24	20	14																
Shut-off PSI		116	107	99	90	81	73	64	55	47	38	16									
3	0				45	44	42	42	41	38	32	28	18								
	10				45	44	42	40	38	36	29	23	12								
	20				45	43	42	40	37	35	32	30	24	13							
	30			45	43	41	39	37	34	32	29	27	20								
	40		44	43	41	39	37	34	32	29	27	24	14								
	50	44	43	41	39	37	34	32	29	27	24	14									
	60	43	41	39	36	34	31	29	26	24	21										
	70	40	38	36	33	31	28	26	23	20	15										
	80	38	35	33	30	28	25	23	19	15											
Shut-off PSI		163	154	145	137	128	120	111	102	94	85	63	42	20							
5	0									45	43	40	37	33	30	26	21	12			
	10									45	44	42	39	35	32	28	24	18			
	20								45	45	44	43	40	37	34	30	26	21	13		
	30							45	45	44	43	42	39	35	32	28	24	18			
	40					45	44	44	43	42	41	37	34	30	27	22	14				
	50				45	44	44	43	42	40	39	36	32	29	25	19					
	60			45	44	43	42	41	40	39	38	34	31	27	22	15					
	70		45	44	43	42	41	40	39	37	36	32	29	25	19						
	80	45	44	43	42	41	40	38	37	36	34	31	27	23	15						
Shut-off PSI		268	259	250	242	233	224	216	207	198	190	168	146	125	103	81	60	38	16		
7.5	0								44	42	40	38	36	34	32	30	27	24	19	13	
	10								45	43	41	39	38	36	33	31	29	26	22	17	10
	20								44	42	40	39	37	35	32	30	27	24	20	14	
	30						45	43	41	40	38	36	34	31	29	26	22	17	11		
	40					44	42	41	39	37	35	33	30	27	24	20	14				
	50					45	43	42	40	38	36	34	32	29	25	22	18	11			
	60				45	44	43	41	39	37	35	33	30	28	24	20	15				
	70		45	45	44	43	42	40	38	36	34	32	29	26	23	18	12				
	80	45	45	44	43	43	41	39	37	35	33	31	28	25	21	15					
Shut-off PSI		373	364	355	347	338	316	295	274	251	230	208	186	165	143	121	100	78	56	35	
10	0					45	44	43	41	40	38	36	35	33	31	30	28	25	22	17	11
	10					45	43	42	41	39	37	36	34	32	31	29	26	24	20	15	
	20				45	44	43	41	40	38	37	35	33	32	30	28	25	22	18	12	
	30				45	43	42	41	39	38	36	34	32	31	29	27	24	20	15		
	40			45	44	43	41	40	38	37	35	33	32	30	28	25	22	18	12		
	50			45	44	42	41	39	38	36	34	33	31	29	27	24	20	16			
	60		45	44	43	42	40	39	37	35	34	32	30	28	26	23	18	13			
	70		45	44	42	41	39	38	36	34	33	31	29	27	24	21	16				
	80	45	44	43	42	40	38	37	35	34	32	30	28	26	23	19	13				
Shut-off PSI		439	418	396	374	353	331	309	288	266	245	223	201	180	158	136	115	93	71	50	28

Notes: 1. Performance shown does not include friction loss in the drop pipe.
 2. All performance data is based on rated motor nameplate voltage.

Submersible Pumps

4" High Capacity Pumps - 35 GPM

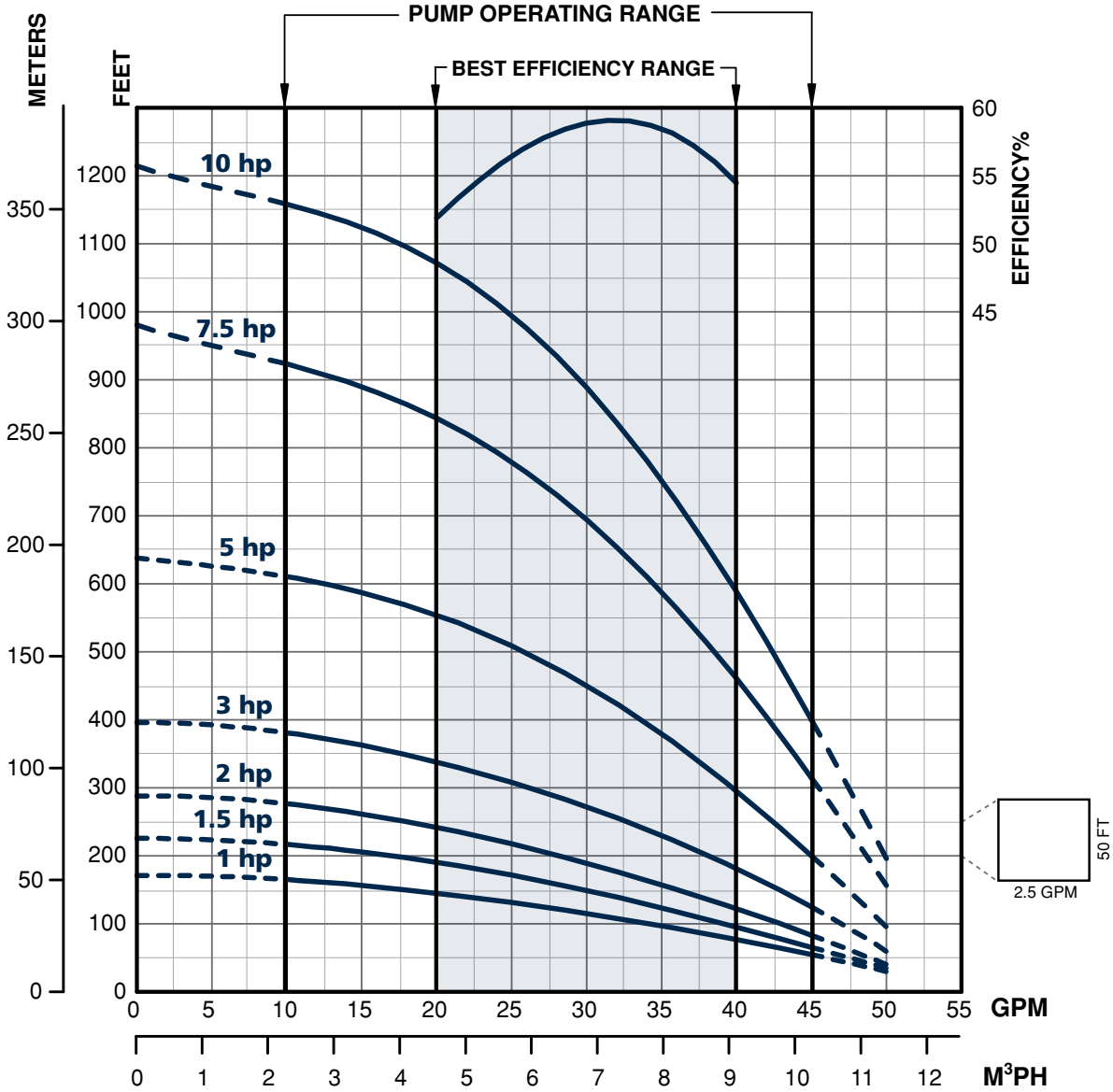

Submersible Pumps

4" High Capacity Pumps - 45 GPM

Capacities in U.S. Gallons per Minute

HP	PSI	Depth to Pumping Water Level, or Lift, in Feet. Shaded Areas Indicate Most Efficient Performance																			
		20	40	60	80	100	120	140	160	180	200	250	300	350	400	450	500	550	600	650	
1.5	0																				
	10			55	51	52	46	38	30	21											
	20	54	50	43	35	27	18														
	30	49	42	34	26	16															
	40	41	33	24	15																
	50	32	23																		
	60	22																			
Shut-off PSI		74	65	56	48	39	30	22	13												
2	0				55	51	46	41	36	30	23										
	10			55	50	45	40	35	29	22											
	20		54	49	44	39	34	28	21												
	30	53	49	44	38	33	27	19													
	40	48	43	38	32	26	18														
	50	42	37	31	24	17															
	60	36	30	23	16																
Shut-off PSI		99	91	82	74	65	56	48	39	30	22										
3	0							53	49	46	42	38	27								
	10				55	52	49	45	41	37	33	21									
	20			55	52	48	45	41	37	32	26										
	30		54	51	48	44	40	36	32	27	22										
	40	54	51	47	44	40	35	31	26	21	15										
	50	50	47	43	39	35	30	25	20												
	60	46	42	38	34	30	25	19													
	70	42	38	33	29	24	18														
	80	37	33	28	23	17															
	90	32	27	22	16																
	100	27	21	16																	
Shut-off PSI		137	129	120	111	103	94	85	77	68	60	38									
5	0									54	52	48	43	38	32	26	17				
	10								55	54	52	50	46	41	36	30	22				
	20								55	53	52	50	48	43	38	33	26	18			
	30								55	53	51	50	48	46	41	36	30	23			
	40				55	53	51	49	47	46	44	39	33	27	19						
	50			54	53	51	49	47	45	43	42	36	31	23							
	60		54	52	51	49	47	45	43	41	39	34	27	19							
	70	54	52	50	48	47	45	43	41	39	37	31	24	15							
	80	52	50	48	46	44	43	41	39	36	34	28	20								
	90	50	48	46	44	42	40	38	36	34	31	25	16								
	100	48	46	44	42	40	38	36	34	31	28	21									
	110	45	44	42	40	38	35	33	31	28	25	17									
	120	43	41	39	37	35	33	30	28	25	21										
	130	41	39	37	35	32	30	27	24	21	17										
	140	39	37	34	32	29	27	24	20	17											
	150	36	34	32	29	26	23	20	16												
	160	28	25	22	18																
Shut-off PSI		240	232	223	214	206	197	188	180	171	162	141	119	97	76	54	32				
7.5	0											54	51	47	43	39	35	30	25	20	
	10											55	52	49	45	41	37	33	28	23	17
	20										55	54	51	47	44	39	35	30	26	20	
	30										55	54	53	49	46	42	37	33	28	23	17
	40										55	54	52	51	48	44	40	35	31	26	15
	50										55	53	52	51	49	46	42	38	33	29	18
	60										54	53	52	51	49	48	44	40	36	31	15
	70			55	54	53	52	50	49	48	46	44	40	36	34	29	24	18			
	80		55	54	53	52	50	49	47	46	44	40	36	32	27	21	16				
	90	55	54	53	51	50	49	47	46	44	43	38	34	29	24	19					
	100	54	52	51	50	48	47	45	44	42	41	36	32	27	22	16					
	110	52	51	50	48	47	45	44	42	40	39	34	30	25	19						
	120	51	49	48	47	45	43	42	40	39	37	32	27	22	17						
	130	49	48	46	45	43	42	40	38	37	35	30	25	20							
	140	48	46	45	43	41	40	38	36	34	33	28	23	17							
	150	46	44	43	41	39	38	38	34	32	30	26	20								
	160	40	39	37	35	33	31	30	28	26	24	18									
Shut-off PSI		331	323	314	305	297	288	279	271	262	254	232	210	189	167	145	124	102	80	59	

- Notes:**
1. Performance shown does not include friction loss in the drop pipe.
 2. All performance data is based on rated motor nameplate voltage.
 3. Performances for former XP models are the same as 45 gpm models.

Submersible Pumps

4" High Capacity Pumps - 45 GPM

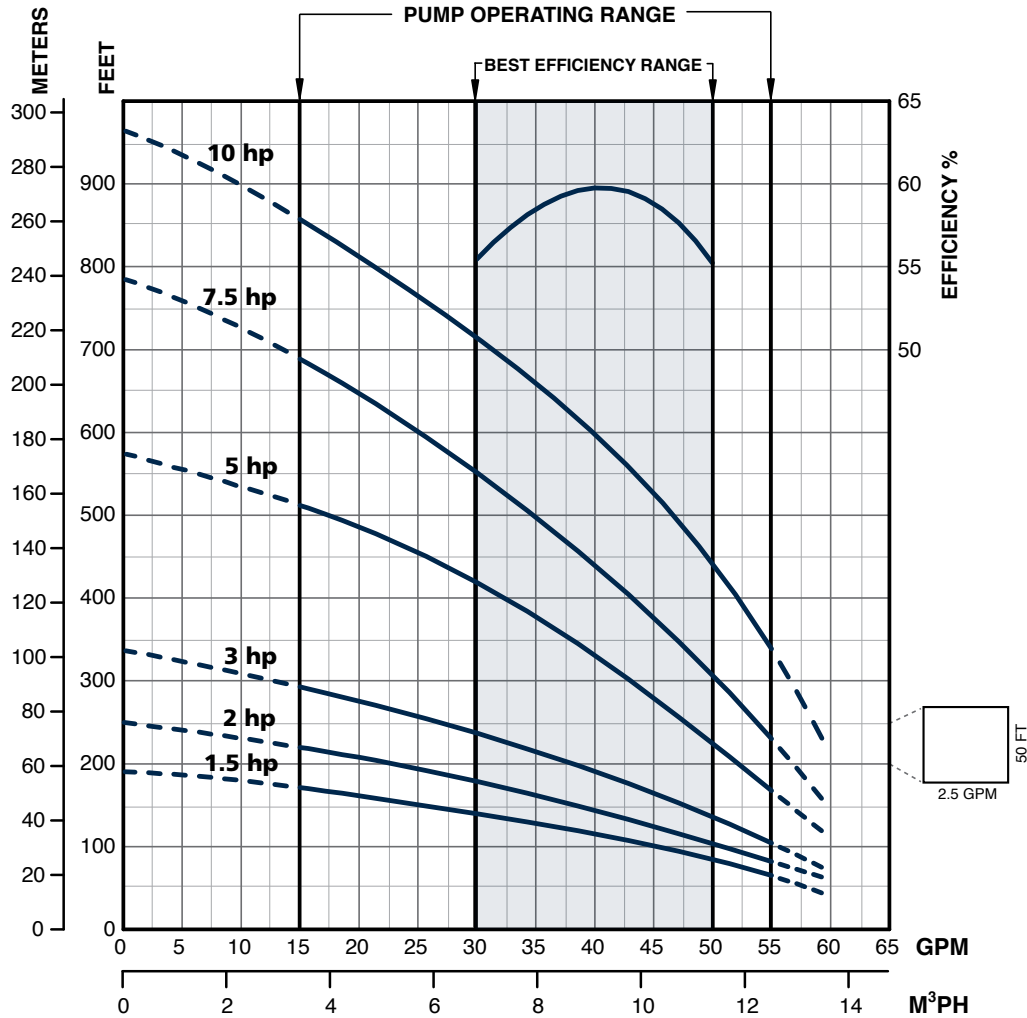

Capacities in U.S. Gallons per Minute

HP	PSI	Depth to Pumping Water Level, or Lift, in Feet. Shaded Areas Indicate Most Efficient Performance																						
		20	40	60	80	100	120	140	160	180	200	250	300	350	400	450	500	550	600	650	700	750	800	850
10	0												55	53	50	48	45	42	39	35	31	27	22	16
	10												54	52	49	47	44	41	37	33	29	24	19	
	20												53	51	48	45	42	39	36	32	27	22	16	
	30											54	52	49	47	44	41	37	34	30	25	19		
	40											53	51	48	45	43	39	36	32	27	22	17		
	50										55	52	50	47	44	41	38	34	30	25	20			
	60								55	55	54	51	48	46	43	40	36	32	28	23	17			
	70						55	54	53	52	51	49	46	43	40	38	34	30	26	20	14			
	80					55	54	53	52	51	49	46	43	40	36	32	28	23	18					
	90					55	54	53	52	51	50	47	45	42	38	35	31	26	21	15				
	100				55	54	53	52	51	50	49	46	43	40	37	33	28	24	18					
	110			55	54	53	52	51	50	49	48	45	42	39	35	31	26	21	15					
	120		55	54	53	52	51	50	49	47	46	43	40	37	33	29	24	19						
	130	54	53	52	51	50	49	48	47	46	45	42	39	35	31	27	22	16						
	140	53	52	51	50	49	48	47	46	45	44	41	37	33	29	24	19							
	150	52	51	50	49	48	47	46	45	44	42	39	36	32	27	22	16							
	160	49	48	46	45	44	43	42	40	39	38	34	30	25	20									
Shut-off PSI		410	402	393	385	376	367	359	350	341	333	311	289	268	246	224	201	179	158	136	115	93	71	50

- Notes:**
1. Performance shown does not include friction loss in the drop pipe.
 2. All performance data is based on rated motor nameplate voltage.
 3. Performances for former XP models are the same as 45 gpm models.

Submersible Pumps

4" High Capacity Pumps - 60 GPM

Capacities in U.S. Gallons per Minute

HP	PSI	Depth to Pumping Water Level, or Lift, in Feet. Shaded Areas Indicate Most Efficient Performance																		
		20	40	60	80	100	120	140	160	180	200	250	300	350	400	450	500	550		
2	0				66	57	47	35	21											
	10			65	56	45	33	18												
	20	71	63	54	43	30														
	30	62	52	41	28															
	40	51	40	26																
	50	38	24																	
	60	22																		
Shut-off PSI		76	67	58	50	41	32	24	15											
3	0					70	66	60	53	46	37									
	10				69	65	59	62	44	35	25									
	20		73	69	64	56	51	43	34	24										
	30	72	68	63	57	50	42	32	22											
	40	67	62	56	49	40	31	20												
	50	61	55	48	39	29														
	60	54	46	37	28															
Shut-off PSI		106	97	89	80	71	63	54	45	37	28									
5	0							71	68	65	62	54	42	27						
	10						70	68	65	62	59	49	36							
	20					70	67	64	61	58	54	43	28							
	30			72	69	67	64	61	57	54	50	37	20							
	40		72	69	68	63	60	57	53	49	44	29								
	50	71	69	66	63	60	56	53	48	43	38	21								
	60	68	65	62	59	56	52	48	43	37	31									
	70	65	62	59	55	51	47	42	36	30	23									
	80	61	58	55	51	46	41	35	28	21										
	90	58	54	50	45	40	34	27	20											
	100	54	49	45	39	33	26													
Shut-off PSI		175	167	158	149	141	132	123	115	106	97	76	54	32						
7.5	0								71	68	63	56	48	38	27					
	10						72	70	68	66	59	52	43	33	22					
	20					72	70	68	65	63	56	48	39	28						
	30				72	70	67	65	63	60	53	44	34	23						
	40			71	69	67	65	62	60	57	49	40	29							
	50		71	69	67	64	62	59	56	53	45	35	24							
	60		68	66	64	61	59	56	53	49	40	30								
	70	70	68	66	64	61	58	55	52	48	45	36	25							
	80	68	66	63	61	58	55	52	48	45	41	31								
	90	65	63	60	57	54	51	48	44	41	37	26								
	100	62	60	57	54	51	47	44	40	36	32	20								
	110	59	57	53	50	47	43	39	35	31	26									
	120	56	53	50	46	43	39	35	30	26	21									
	130	52	49	46	42	38	34	30	25	20										
	140	49	45	41	37	33	29	24	19											
	150	45	41	37	33	28	24													
	160	31	26	21																
Shut-off PSI		232	223	214	206	197	188	180	171	162	154	132	110	89	67	45				
10	0										69	65	61	57	51	45	39	31	22	
	10										71	67	63	59	54	49	42	35	27	
	20							72	71	69	66	61	57	52	46	39	31	23		
	30						72	71	69	68	64	59	55	49	43	36	28			
	40					72	70	69	67	66	62	57	52	46	40	32	24			
	50				72	70	69	67	66	64	60	55	50	43	36	28				
	60			72	70	68	67	65	64	62	58	53	47	40	33	24				
	70			71	70	68	67	65	64	62	60	55	50	44	37	29	20			
	80		71	70	68	66	65	63	62	60	58	53	47	41	33	25				
	90	71	69	68	66	65	63	61	60	58	56	51	44	37	29	21				
	100	69	68	66	64	63	61	59	57	56	53	48	41	34	26					
	110	67	66	64	62	61	59	57	55	53	51	45	38	30	22					
	120	65	64	62	61	59	57	55	53	51	48	42	34	26						
	130	64	62	60	58	57	55	52	51	48	45	39	31	22						
	140	62	60	58	56	54	52	50	48	45	42	35	27							
	150	60	58	56	54	52	50	47	45	42	39	31	23							
	160	53	51	48	46	43	41	38	35	31	28									
Shut-off PSI		326	317	308	300	291	282	274	265	256	248	226	204	183	161	139	118	96	74	53

- Notes:**
1. Performance shown does not include friction loss in the drop pipe.
 2. All performance data is based on rated motor nameplate voltage.
 3. Performances for former XP models are the same as 60 gpm models.

Submersible Pumps

4" High Capacity Pumps - 60 GPM

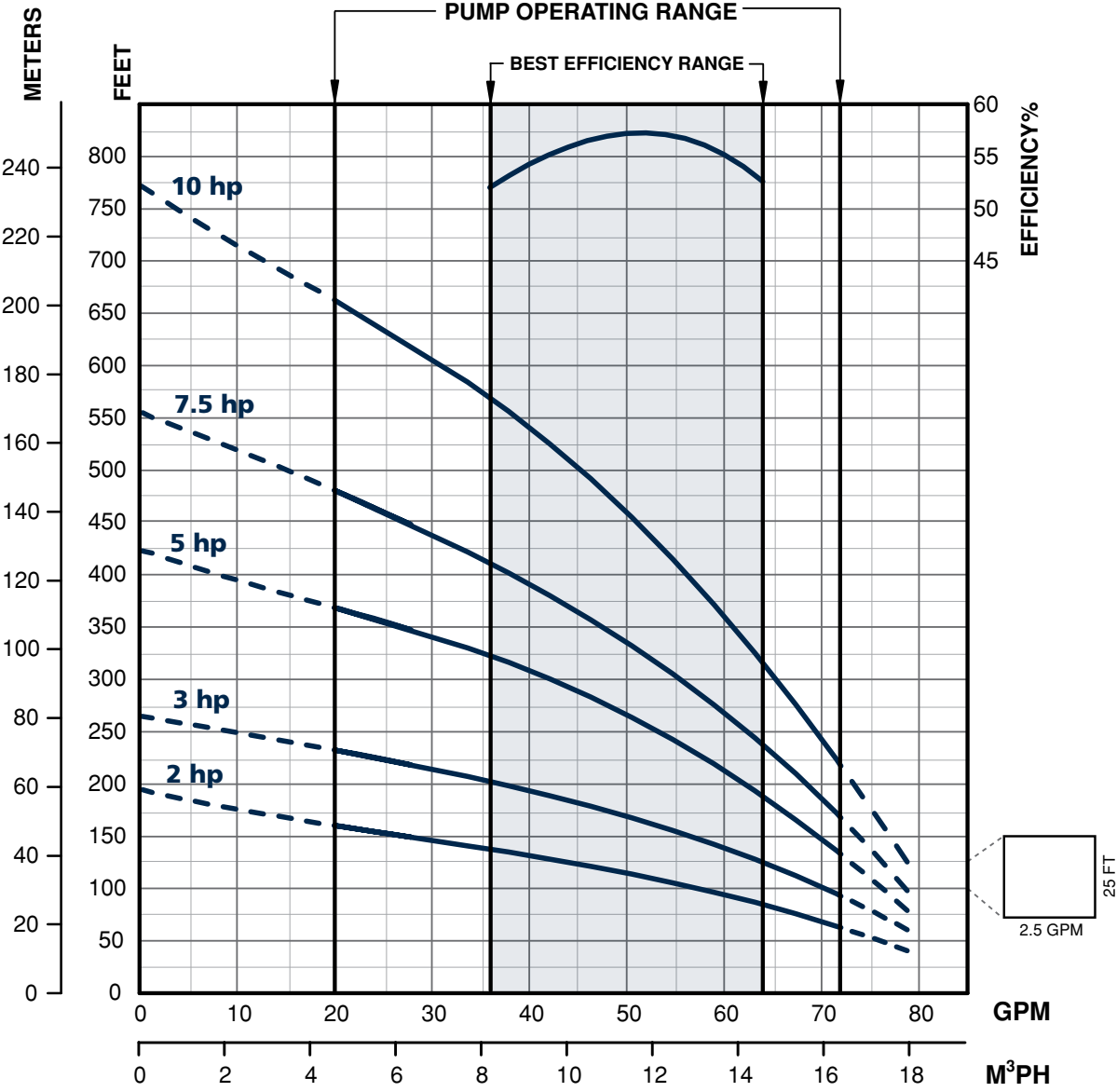

Submersible Pumps

4" High Capacity Pumps - 90 GPM

Capacities in U.S. Gallons per Minute

HP	PSI	Depth to Pumping Water Level, or Lift, in Feet. Shaded Areas Indicate Most Efficient Performance																			
		20	40	60	80	100	120	140	160	180	200	250	300	350	400	450	500	550			
2	0		113	92	67	48														Shut-off 120 ft	
	10	110	88	64	45																
	20	84	61	40																	
	30	58	35																		
	40																				
	50																				
	60																				
Shut-off PSI		43	35	26	17	9															
3	0			110	96	79	64	49												Shut-off 167 ft	
	10		108	93	76	61	46														
	20	106	90	74	59	43															
	30	88	71	57	39																
	40	69	55	35																	
	50	53	30																		
	60																				
Shut-off PSI		64	55	46	38	29	20	12													
5	0					113	106	96	85	74	64	41								Shut-off 285 ft	
	10				112	104	94	83	72	63	55										
	20			111	103	92	81	71	62	53	44										
	30		110	101	91	80	69	60	52	42											
	40	100	100	89	78	68	59	51	40												
	50	98	87	76	66	58	49	38													
	60	85	75	65	56	48	35														
	70	73	63	55	46	33															
	80	62	54	45	30																
	90	53	43																		
	100	41																			
Shut-off PSI		115	106	97	89	80	71	63	54	45	37	15									
7.5	0						116	112	107	101	94	76	60	46						Shut-off 425 ft	
	10					115	111	108	100	93	86	68	54	38							
	20				115	110	105	99	92	85	77	61	47								
	30			114	109	104	98	91	83	76	70	55	40								
	40		113	109	103	96	90	82	75	69	62	49									
	50	113	108	102	95	88	81	74	68	61	56	41									
	60	107	101	94	87	80	73	67	61	55	50	31									
	70	100	93	86	79	72	66	60	54	49	42										
	80	92	85	78	71	65	59	53	48	41	33										
	90	84	77	70	64	58	53	47	40	31											
	100	76	69	63	57	52	46	39													
	110	68	62	56	51	45	38														
	120	61	55	50	44	36															
	130	55	49	43	35																
	140	48	42	33																	
	150	41	32																		
	160																				
Shut-off PSI		175	167	158	149	141	132	123	115	106	97	76	54	32							
10	0					122	119	116	112	109	106	99	91	83	75	65	54	42	35	11	Shut-off 565 ft
	10				122	119	116	112	109	106	102	95	87	78	69	59	48	34	25		
	20			121	118	115	112	108	105	101	98	90	82	73	64	53	40	24	13		
	30		121	118	115	111	108	104	101	97	94	86	77	68	57	46	31	11			
	40	120	117	114	111	107	104	100	97	93	89	81	72	62	51	38	21				
	50	117	114	110	107	103	100	96	92	88	84	76	66	56	44	29	7				
	60	113	110	106	103	99	96	92	88	84	79	70	60	49	35	18					
	70	109	106	102	99	95	91	87	83	79	74	65	54	41	26	2					
	80	105	102	98	94	91	87	82	78	74	69	59	47	33	14						
Shut-off PSI		236	227	219	210	201	193	184	175	167	158	141	123	106	89	71	54	37	28	6	

- Notes: 1. Performance shown does not include friction loss in the drop pipe.
 2. All performance data is based on rated motor nameplate voltage.

Submersible Pumps

4" High Capacity Pumps - 90 GPM

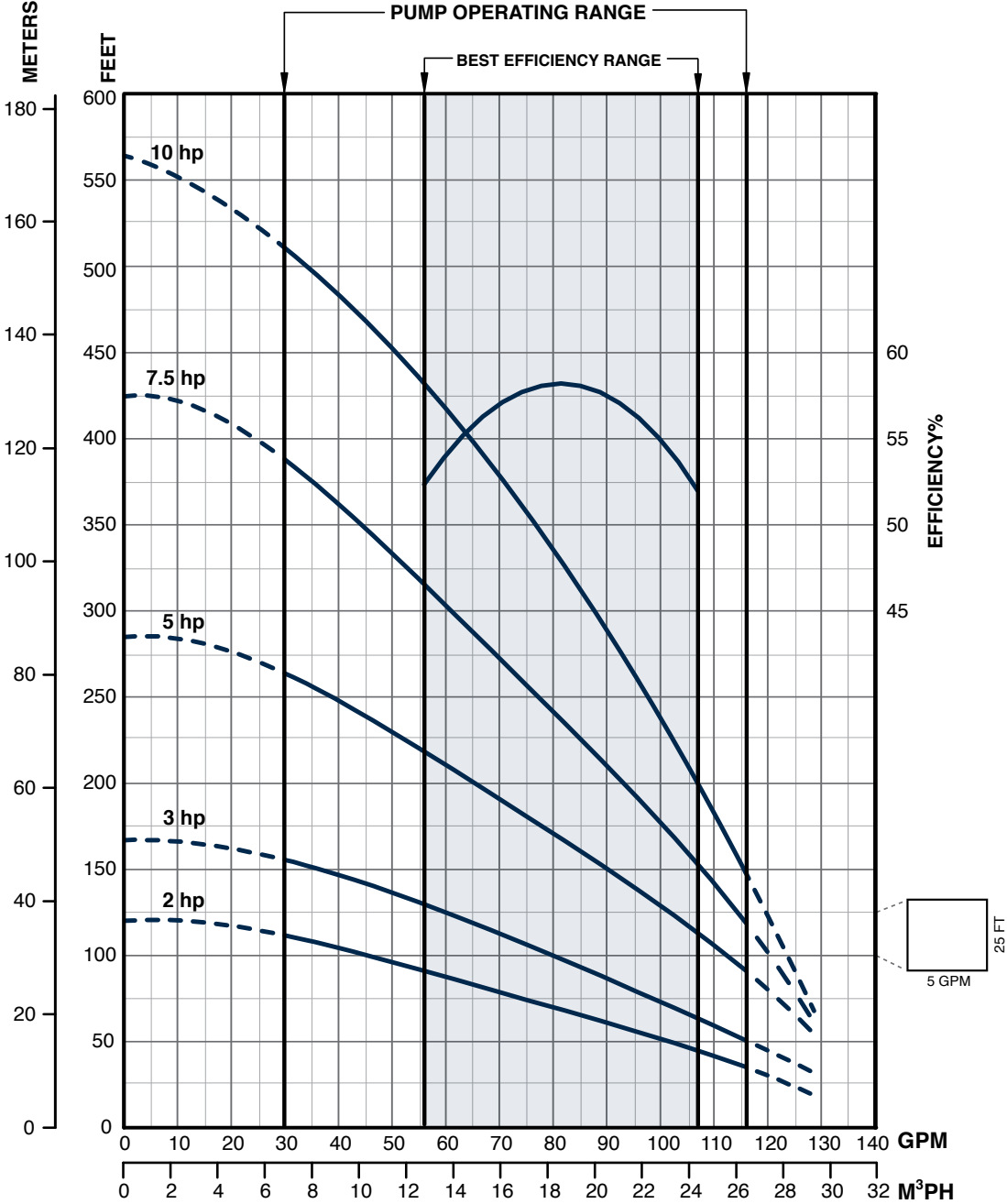

Submersible Pumps

6" High Capacity Pump - Features



FPS4400

6" High Capacity Pumps

Ideal for farm, home, irrigation, industry, municipal and commercial applications, equipped with the power, performance, and reliability you expect from Franklin Electric.

Flow ratings of 50, 75, 100, and 125 gpm with TDH up to 1200 ft.

Horsepower ranges from 1-1/2 to 40 hp.

Features:

- Heavy-duty stainless steel discharge head and motor bracket.
- Stainless steel shaft, shell, intake screen, and cable guard provides corrosion resistance and longer pump life.
- Glass-filled Noryl® impeller stage assemblies provide exceptional strength and durability.
- Ceramic shaft sleeve and rubber discharge bearing minimizes bearing wear and shaft misalignment.
- 3" NPT heavy-duty stainless steel discharge head.
- Modular motor bracket enabling 4" or 6" motor mount for 5-10 hp units.
- One year unconditional warranty against failure from sand locking in abrasive well conditions.

Noryl® is a registered trademark of G.E.

Submersible Pumps

6" High Capacity Pumps - Ordering Information

Stainless Steel Ordering Information

6" Pump Ends							
GPM	HP	Stages	Motor Fit	Ordering Info.		Dimensions	Wt.
				Model No.	Order No.	Pump End Only	
50	1.5	3	4"	50FA1S6-PE	94825003	13.51	30
	2	4	4"	50FA2S6-PE	94825004	15.13	31
	3	5	4"	50FA3S6-PE	94825005	16.76	32
	5	8	4" & 6"	50FA5S6-PE	94825008	21.63	36
	7.5	11	4" & 6"	50FA7S6-PE	94825011	26.51	40
	10	15	4" & 6"	50FA10S6-PE	94825015	32.94	46
	15	22	4" & 6"	50FA15S6-PE	94825022	47.64	54
75	3	3	4"	75FA3S6-PE	94827503	13.51	30
	5	5	4" & 6"	75FA5S6-PE	94827505	16.76	32
	7.5	7	4" & 6"	75FA7S6-PE	94827507	20.01	35
	10	9	4" & 6"	75FA10S6-PE	94827509	23.26	38
	15	13	6"	75FA15S6-PE	94827513	29.76	43
	20	17	6"	75FA20S6-PE	94827517	36.19	48
	25	23	6"	75FA25S6-PE	94827523	46.00	54
100	5	3	4" & 6"	100FA5S6-PE	94820003	14.62	30
	7.5	5	4" & 6"	100FA7S6-PE	94820005	18.51	32
	10	6	4" & 6"	100FA10S6-PE	94820006	20.49	34
	15	9	6"	100FA15S6-PE	94820009	26.31	38
	20	13	6"	100FA20S6-PE	94820013	34.07	43
	25	16	6"	100FA25S6-PE	94820016	39.94	47
125	5	2	4" & 6"	125FA5S6-PE	94822502	12.94	29
	7.5	3	4" & 6"	125FA7S6-PE	94822503	15.05	30
	10	4	4" & 6"	125FA10S6-PE	94822504	17.13	31
	15	7	6"	125FA15S6-PE	94822507	23.37	35
	20	9	6"	125FA20S6-PE	94822509	27.54	38
	25	11	6"	125FA25S6-PE	94822511	31.70	40
	30	13	6"	125FA30S6-PE	94822513	35.87	43
	40	18	6"	125FA40S6-PE	94822518	46.27	48

Notes: All dimensions are in inches. Discharge is 3" NPT.

Maximum diameter across cable guard is 5.5" on all models. Weight in pounds.

Submersible Pumps

6" High Capacity Pumps - 50 GPM

Capacities in U.S. Gallons per Minute

HP	PSI	Depth to Pumping Water Level, or Lift, in Feet. Shaded Areas Indicate Most Efficient Performance																							
		20	40	60	80	100	120	140	160	180	200	250	300	350	400	450	500		550						
1.5	0				68	61	51	41	30											Shut-off 158 ft					
	20	66	58	47	38	25																			
	30	56	46	37	21																				
	40	44	35	16																					
	50	33																							
Shut-off PSI		60	51	43	34	25	17	8																	
2	0					69	63	57	49	41	31	16								Shut-off 211 ft					
	20		67	62	54	46	38	27																	
	30	67	60	53	45	37	25																		
	40	59	52	44	35	23																			
	50	51	42	34	20																				
	60	41	32	17																					
Shut-off PSI		83	74	65	57	48	39	31	22	13	5														
3	0						70	66	61	55	49	42	17						Shut-off 263 ft						
	20			69	65	60	53	47	40	33	21														
	30		68	64	59	52	46	39	31	18															
	40	68	63	58	51	45	38	30	15																
	50	63	57	50	44	37	28																		
Shut-off PSI		105	97	88	79	71	62	53	45	36	27	6													
5	0									70	67	64	55	45	34				Shut-off 418 ft						
	20							69	66	63	60	56	46	35	16										
	30						69	66	63	59	56	51	41	28											
	40				68	66	62	59	55	51	47	36	18												
	50		70	68	65	62	58	54	50	46	42	29													
	60	70	67	65	61	58	54	50	45	41	37	20													
Shut-off PSI		173	164	155	147	138	129	121	112	103	95	73	51	30											
7.5	0												68	63	57	49	42	32	18	Shut-off 591 ft					
	20										70	68	63	57	50	42	33	19							
	30									70	68	66	60	54	47	38	27								
	40								70	68	66	64	58	51	43	34	21								
	50							69	67	65	63	61	54	47	39	28									
Shut-off PSI		247	239	230	221	213	204	195	187	178	169	148	126	104	83	61	39	18							
10	0											68	64	59	54	49	43	37	28	18	Shut-off 808 ft				
	20										68	64	60	55	50	44	37	29	19						
	30									70	66	62	57	52	47	41	34	25							
	40									68	64	60	55	50	44	38	30	20							
	50								70	66	62	58	53	47	41	34	26								
	60							70	68	65	60	56	50	45	38	31	21								
Shut-off PSI		306	298	289	281	272	263	242	220	198	177	155	133	112	90	68	47	25							
15	0									80	78	76	74	72	70	68	65	62	59	56	53	49	46	Shut-off 1129 ft	
	20									79	77	76	74	72	70	68	65	62	59	56	53	50	46		42
	40				80	79	78	77	76	75	74	72	70	68	65	63	60	57	53	50	46	43	38		
	60	80	78	77	76	76	75	74	73	72	70	68	66	63	60	57	54	50	47	43	39	34	34		
	80	77	76	75	75	74	73	72	71	71	68	66	63	60	57	54	50	47	43	39	34	29	29		
	100	75	74	73	73	72	71	70	69	68	66	63	60	57	54	51	47	43	39	35	29	22	22		
	120	73	72	72	71	70	69	68	67	66	64	61	58	54	51	47	44	40	35	30	23	14	14		
	140	71	71	70	69	68	67	66	65	64	61	58	55	51	48	44	40	36	30	23	14	3	3		
	160	67	66	65	64	62	62	61	59	58	55	52	48	45	41	36	31	24	16	5					
	Shut-off PSI										411	402	380	359	337	315	294	272	250	229	207	186	164		142

Discharge 3" NPT.

- Notes: 1. Performance shown does not include friction loss in the drop pipe.
 2. All performance data is based on rated motor nameplate voltage.

Submersible Pumps

6" High Capacity Pumps - 50 GPM

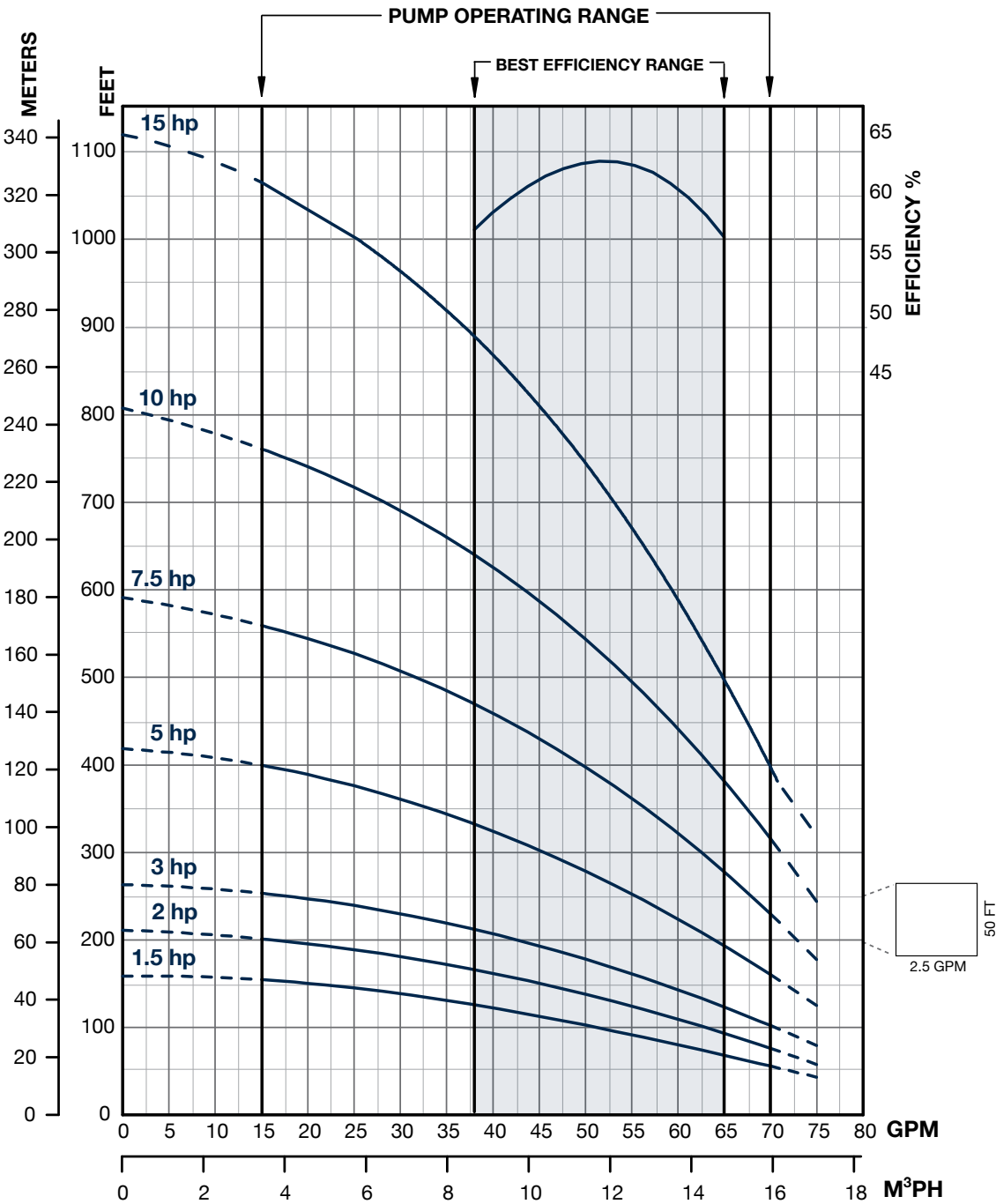

Submersible Pumps

6" High Capacity Pumps - 75 GPM

Capacities in U.S. Gallons per Minute

HP	PSI	Depth to Pumping Water Level, or Lift, in Feet. Shaded Areas Indicate Most Efficient Performance																				
		20	40	60	80	100	120	140	160	180	200	250	300	350	400	450	500		550			
3	0																			Shut-off 162 ft		
	20	106	98	85	73	57																
	30	96	83	72	53																	
	40	81	70	47																		
	50	68	40																			
Shut-off PSI		61	53	44	35	27	18	9	1													
5	0					116	106	102	96	88	79	73	41							Shut-off 259 ft		
	20		112	105	100	93	85	77	71	64	47											
	30	110	104	99	92	84	76	70	63	43												
	40	103	98	91	82	75	69	61	37													
	50	97	89	81	74	68	58	31														
	60	88	80	73	67	56	24															
Shut-off PSI		103	95	86	77	69	60	51	43	34	25	4										
7.5	0							116	109	105	101	97	83	70	54					Shut-off 387 ft		
	20				114	108	104	100	96	90	85	71	56									
	30			112	107	103	99	95	89	84	78	65	40									
	40		111	106	103	99	94	88	83	77	72	57										
	50	111	106	102	98	93	88	82	76	71	66	43										
	60	105	102	97	92	87	81	76	71	65	59											
Shut-off PSI		159	150	142	133	124	116	107	98	90	81	59	38	16								
10	0								112	109	106	98	88	77	66	50				Shut-off 493 ft		
	20					116	111	108	105	102	99	89	78	67	52							
	30				115	111	107	104	101	98	94	84	73	61	39							
	40			114	110	107	104	101	98	94	89	78	68	54	18							
	50		114	109	106	104	100	97	93	89	84	74	63	42								
	60	113	109	106	103	100	96	92	88	84	79	69	55	22								
Shut-off PSI		205	196	187	179	170	161	153	144	135	127	105	84	62	40	19						
15	0								114	107	102	97	89	81	74	68	60	41			Shut-off 727 ft	
	20					115	107	103	97	90	82	75	69	61	43							
	30				114	110	105	100	94	86	78	72	66	55	28							
	40			113	110	107	103	98	90	82	75	69	62	45								
	50		113	109	107	105	101	95	87	79	73	66	56	31								
	60	112	109	107	105	103	98	91	83	76	70	63	47									
Shut-off PSI		263	254	245	237	228	206	185	163	142	120	98	77	55	33	12						
20	0								113	107	103	100	94	88	82	76	71	66	58	43	Shut-off 936 ft	
	20						113	107	104	100	95	89	82	76	72	67	59	44				
	30						110	106	102	98	92	86	79	74	69	64	54	33				
	40						114	108	104	100	95	89	83	77	72	67	60	46				
	50						110	106	102	98	93	86	80	74	70	64	55	35				
	60					115	108	104	101	96	90	83	77	72	67	61	47					
Shut-off PSI		353	345	336	327	319	297	275	254	232	210	189	167	145	124	102	80	59	37	15		
25	0			116	112	109	107	104	101	97	93	89	84	79	75	70	65	59	50	38	19	Shut-off 1202 ft
	20		116	112	109	107	104	101	98	93	89	84	80	75	70	65	59	51	39	21		
	30		114	111	108	106	103	100	96	91	87	82	78	73	68	63	56	46	31			
	40		112	109	107	104	101	98	94	89	85	80	75	71	66	60	51	40	23			
	50	114	111	108	106	103	100	96	92	87	83	78	73	69	63	56	47	33				
	60	113	110	107	105	102	98	94	90	85	80	76	71	66	60	52	41	24				
Shut-off PSI		412	391	369	347	326	304	283	261	239	218	196	174	153	131	109	88	66	44	23	1	

Discharge 3" NPT.

- Notes: 1. Performance shown does not include friction loss in the drop pipe.
 2. All performance data is based on rated motor nameplate voltage.

Submersible Pumps

6" High Capacity Pumps - 75 GPM

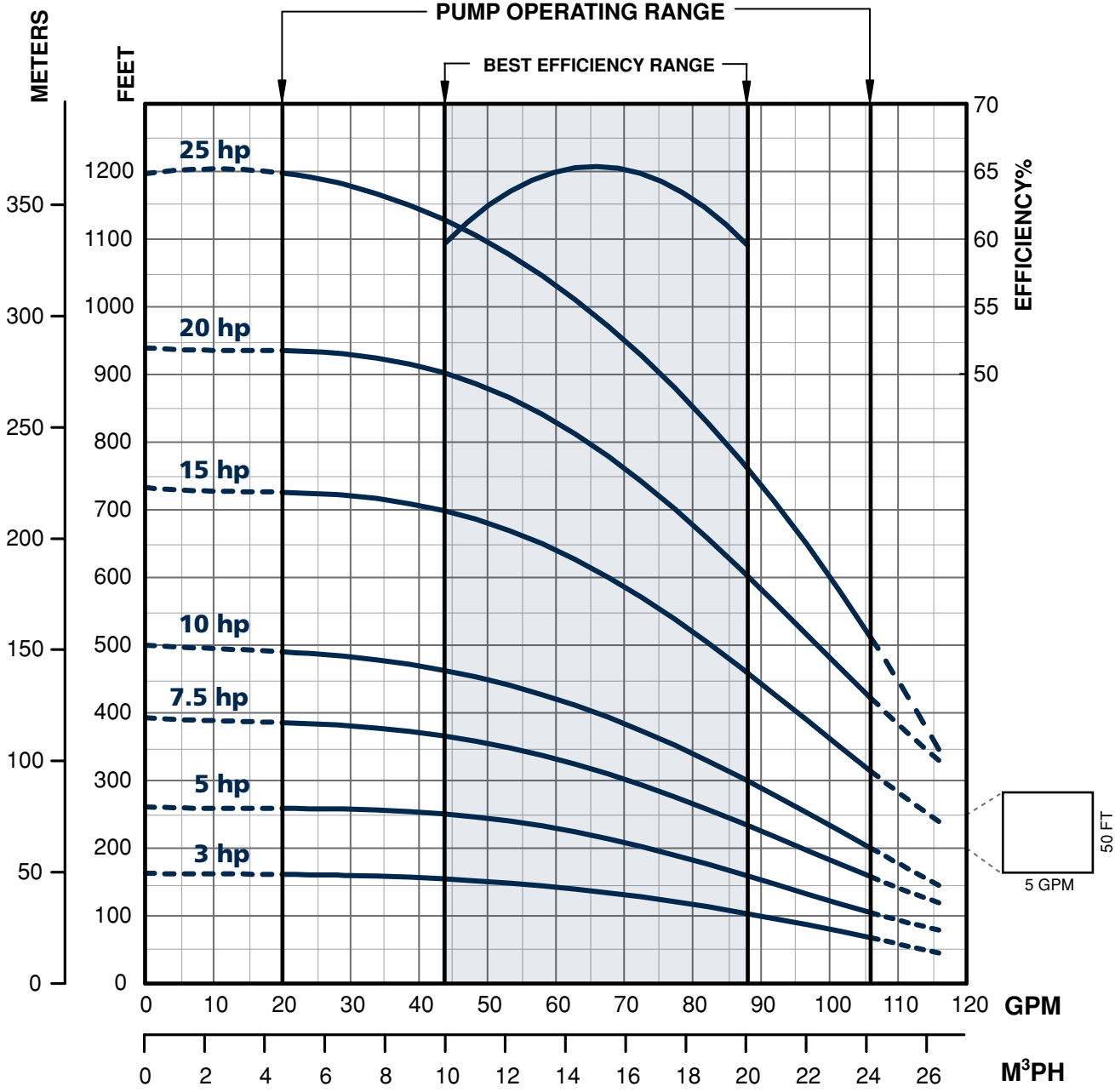

Submersible Pumps

6" High Capacity Pumps - 100 GPM

Capacities in U.S. Gallons per Minute

HP	PSI	Depth to Pumping Water Level, or Lift, in Feet. Shaded Areas Indicate Most Efficient Performance																	
		20	40	60	80	100	120	140	160	180	200	250	300	350	400	450	500		550
5	0					130	119	104	85	62									Shut-off 191 ft
	20		127	115	98	78	54												
	30	125	112	95	75	49													
	40	110	92	71	44														
	50	89	68	38															
	60	64	32																
	70																		
Shut-off PSI		74	65	57	48	39	31	22	13										
7.5	0								131	123	115	107	79	32					Shut-off 320 ft
	20					129	121	113	104	93	82	37							
	30				127	120	111	102	92	79	64								
	40			126	118	110	101	90	77	62	42								
	50		125	117	109	99	88	75	59	38									
	60	124	116	107	97	86	73	56	34										
	70	115	106	96	84	71	53	30											
Shut-off PSI		130	121	113	104	95	87	78	69	61	52	30	9						
10	0									127	121	102	79	45					Shut-off 1393 ft
	20							132	125	118	111	104	81	48					
	30					131	124	117	110	102	94	67	28						
	40				130	123	116	109	101	92	83	51							
	50			129	122	115	108	100	91	81	70	31							
	60		128	121	114	107	99	90	79	68	54								
	70	127	120	113	105	97	88	78	66	52	35								
Shut-off PSI		161	153	144	135	127	118	110	101	92	84	62	40	19					
15	0											123	111	98	82	61	32		Shut-off 590 ft
	20											123	112	99	83	62	34		
	30											129	118	107	93	74	51		
	40									132	128	124	119	108	94	76	53		
	50						131	127	123	119	114	102	86	66	39				
	60					130	126	122	118	113	109	95	78	55					
	70					130	126	122	118	113	109	95	78	55					
Shut-off PSI		247	238	229	221	212	204	195	186	178	169	147	126	104	82	61	39	17	
20	0					127	119	111	103	94	82	69	52						Shut-off 846 ft
	20				127	120	112	104	94	83	70	53	31						
	30			131	124	116	108	99	89	78	63	44							
	40			128	120	112	104	95	84	71	55	33							
	50		132	124	117	109	100	90	79	64	45								
	60		128	121	113	105	96	85	72	56	35								
	70	132	125	117	109	101	91	80	65	47									
Shut-off PSI		280	258	236	215	193	172	150	128	107	85	63	42						
25	0					130	124	118	111	104	96	87	78	67	53	37			Shut-off 1030 ft
	20					130	124	118	112	105	97	88	79	68	55	39			
	30				128	122	116	109	101	93	84	74	62	48	30				
	40			130	125	119	112	105	97	89	79	68	56	40					
	50			128	122	116	109	102	94	85	75	63	49	31					
	60		131	125	119	113	106	98	90	80	69	57	41						
	70		128	123	117	110	102	94	85	75	64	50	33						
Shut-off PSI		359	338	316	294	273	251	229	208	186	164	143	121	99					

Discharge 3" NPT.

- Notes: 1. Performance shown does not include friction loss in the drop pipe.
 2. All performance data is based on rated motor nameplate voltage.

Submersible Pumps

6" High Capacity Pumps - 100 GPM

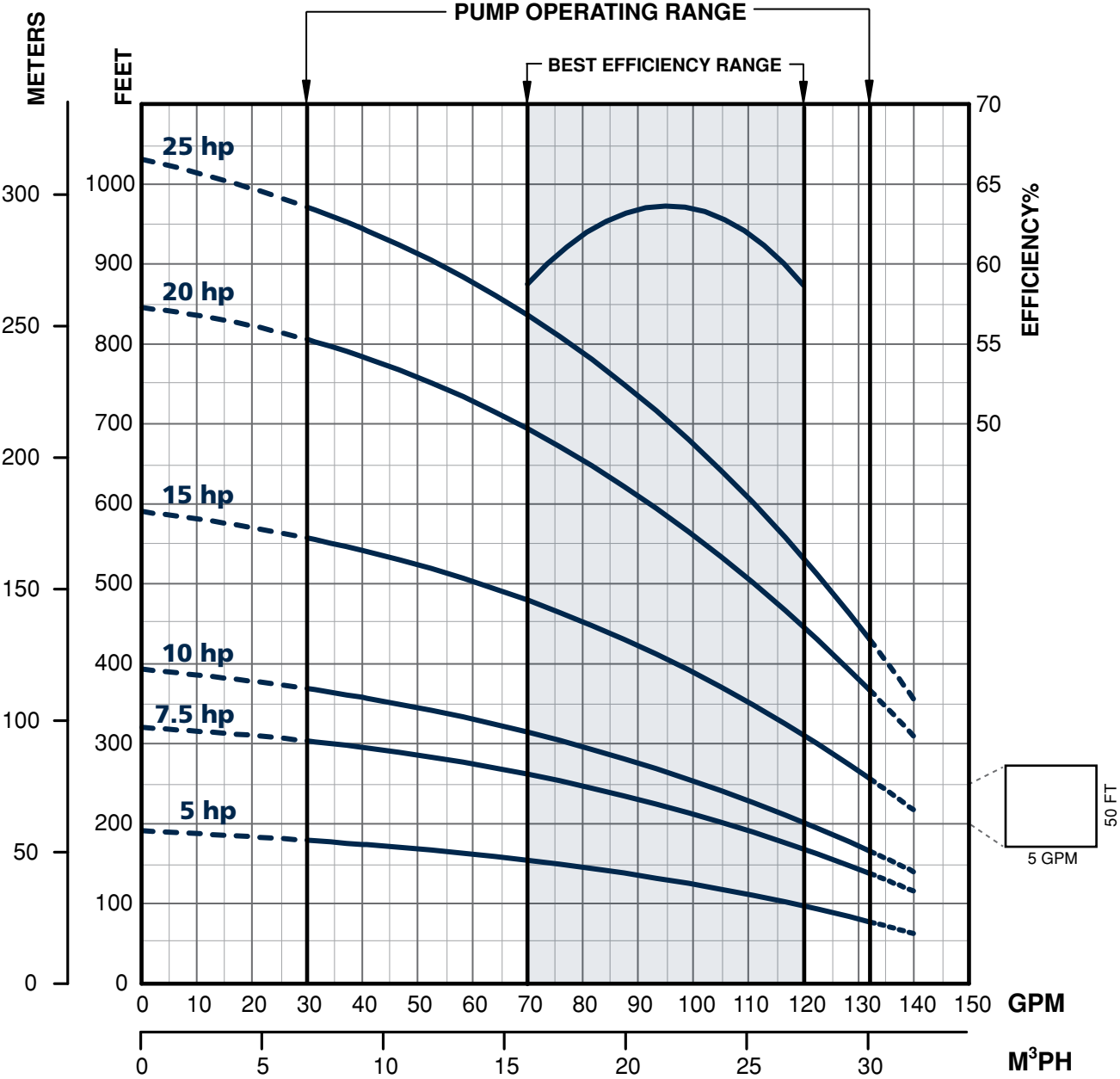

Submersible Pumps

6" High Capacity Pumps - 125 GPM

Capacities in U.S. Gallons per Minute

HP	PSI	Depth to Pumping Water Level, or Lift, in Feet. Shaded Areas Indicate Most Efficient Performance																					
		20	40	60	80	100	120	140	160	180	200	250	300	350	400	450	500	550	600	650			
5	0				140	106	62																
	20		131	94																			
	30	126	88																				
	40	82																					
Shut-off PSI		48	39	30	22	13	4																
7.5	0						141	122	99	64													
	20				135	116	90	48															
	30		150	133	112	85																	
	40	147	130	109	79																		
	50	127	105	73																			
	60	101	67																				
70	60																						
Shut-off PSI		77	69	60	51	43	34	25	17	8													
10	0								143	129	114	45											
	20						139	125	109	88	54												
	30				149	137	122	106	84	47													
	40			148	135	120	103	79															
	50		146	132	118	100	74																
	60	144	130	115	97	69																	
70	128	112	93	63																			
Shut-off PSI		105	97	88	79	71	62	53	45	36	27	6											
15	0												134	112	81								
	20												135	114	84								
	30												145	126	101	65							
	40									144	137	116	87										
	50								149	143	136	128	104	68									
	60						148	142	134	126	117	89	44										
70					147	141	133	125	116	106	72												
Shut-off PSI			185	176	168	159	150	142	133	124	116	94	72	51	29								
20	0													143	129	113	91	59					
	20													144	130	114	93	62					
	30													138	123	105	81	41					
	40												145	131	115	95	65						
	50												139	124	107	83	45						
	60												146	132	117	97	68						
70								150	145	140	125	108	85	49									
Shut-off PSI		252	243	234	226	217	208	200	191	182	174	152	130	109	87	65	44	22					
25	0														143	133	119	99	71				
	20														144	134	120	101	74				
	30														149	140	128	112	90	57			
	40														145	135	121	103	76				
	50													150	140	129	114	92	60				
	60													146	135	123	104	78	42				
70													141	130	115	94	63						
Shut-off PSI				292	283	275	266	257	249	240	231	210	188	166	145	123	101	80	58	37			
30	0																						
	20												150	144	138	132	125	117	107	95	80		
	30												148	142	136	129	122	114	1108	96	82	62	
	40												145	139	133	126	118	109	97	83	64	40	
	50												148	142	136	130	123	114	104	91	75	53	
	60												145	139	133	127	119	110	98	84	66	42	
70												149	143	137	130	123	115	105	92	76	55		
Shut-off PSI		409	387	365	344	322	300	279	257	235	214	192	170										
40	0																						
	20													150	145	139	132	126	118	1108	96	82	62
	30													148	142	136	129	122	114	103	90	73	52
	40													145	139	133	126	118	109	97	83	64	40
	50													148	142	136	130	123	114	104	91	75	53
	60													145	139	133	127	119	110	98	84	66	42
70													149	143	137	130	123	115	105	92	76	55	
Shut-off PSI		409	387	365	344	322	300	279	257	235	214	192	170										

Discharge 3" NPT.

- Notes: 1. Performance shown does not include friction loss in the drop pipe.
 2. All performance data is based on rated motor nameplate voltage.

Submersible Pumps

6" High Capacity Pumps - 125 GPM

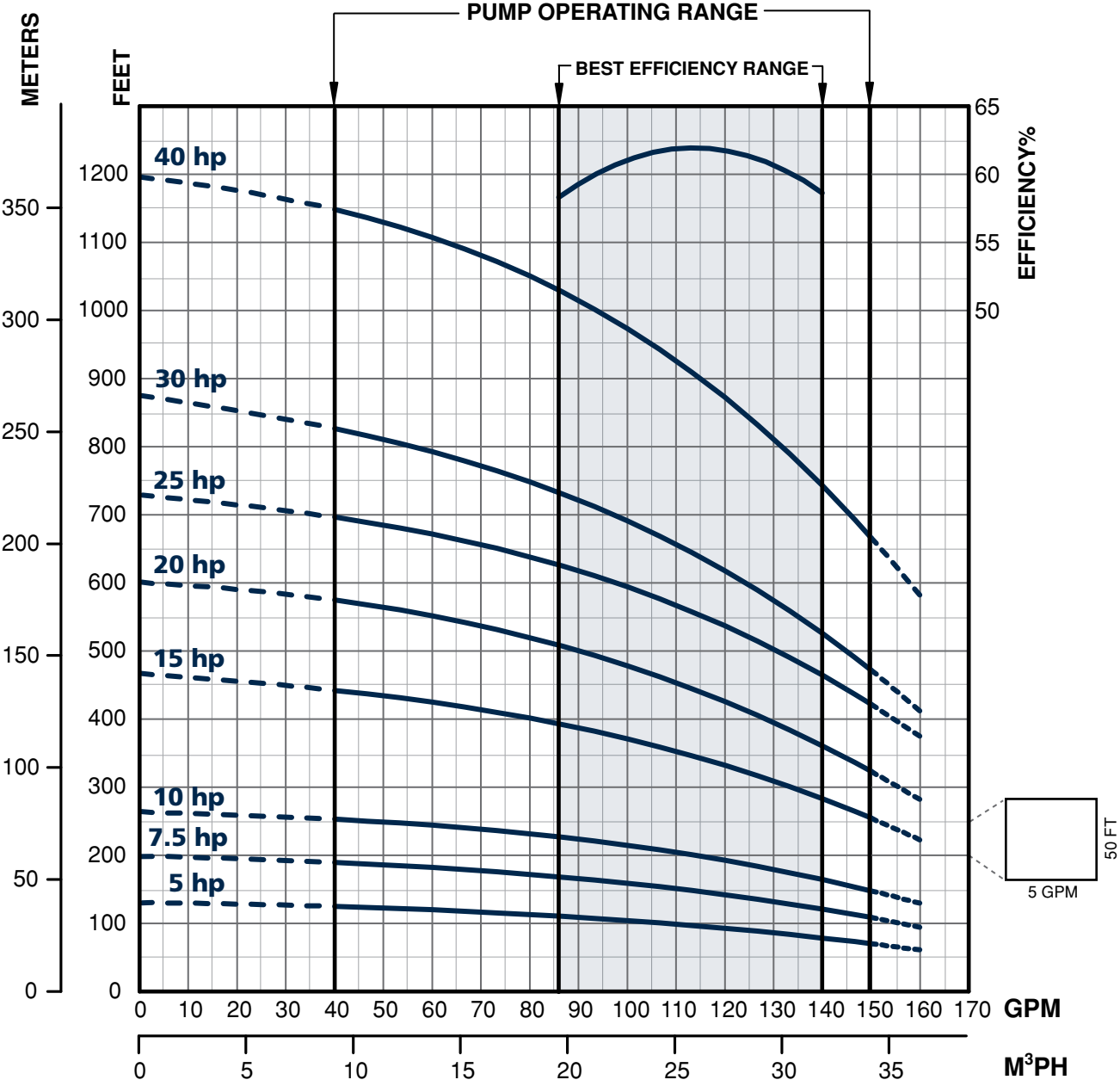

Submersible Pumps

E-Series - Features



Applications:

- Filtered effluent service.
- Aeration.
- Ornamental fountains/waterfalls.

Features:

- Ideal for effluent pumping applications.
- Stainless steel or thermoplastic discharge and motor bracket are tough and non-corrosive. Both materials are highly resistant to damage by minerals, metals, and other substances typically found in water.
- Heavy duty, 300 V, 10' SJOOW motor leads.
- Ceramic bearing sleeve has time proven durability for years of reliable service.
- Hex rubber bearing has extra large surface assuring shaft stability and multiple flow channels keeping particles away from bearing surfaces.
- Proven hydraulic staging allows close tolerances and increased performance.
- Carbon phenolic upthrust washer prevents excessive wear in severe applications.
- Removable built in check valve on 10-20 gpm pumps. No built in check valves on high capacity pumps.
- Powered by a Franklin Electric submersible motor.

Thermoplastic Ordering Information

1/2 - 1.5 HP Single-Phase Units						
GPM	HP	Volt	Wire	Order No.	Model	Wt.
10	1/2	115	2	94741005	10FE05P4-2W115	25
	1/2	230	2	94741010	10FE05P4-2W230	25
	3/4	230	2	94741015	10FE07P4-2W230	29
	1	230	2	94741020	10FE1P4-2W230	33
	1.5	230	2	94741025	10FE15P4-2W230	41
20	1/2	115	2	94742005	20FE05P4-2W115	24
	1/2	230	2	94742010	20FE05P4-2W230	24
	3/4	230	2	94742015	20FE07P4-2W230	28
	1	230	2	94742020	20FE1P4-2W230	31
	1.5	230	2	94742025	20FE15P4-2W230	39

Submersible Pumps

E-Series - Ordering Information

Thermoplastic Ordering Information

1/2 - 2 HP Pump Ends						
GPM	HP	Volt	Wire	Order No.	Model	Wt.
10	1/2	N/A	2	94751005	10FE05P4-PE	7
	3/4	N/A	N/A	94751010	10FE07P4-PE	8
	1	N/A	N/A	94751015	10FE1P4-PE	9
	1.5	N/A	N/A	94751020	10FE15P4-PE	10
20	1/2	N/A	N/A	94752005	20FE05P4-PE	6
	3/4	N/A	N/A	94752010	20FE07P4-PE	6
	1	N/A	N/A	94752015	20FE1P4-PE	7
	1.5	N/A	N/A	94752020	20FE15P4-PE	8
	2	N/A	N/A	94752025	20FE2P4-PE	9

Notes: Discharge is 1-1/4" NPT. Maximum diameter across cable guard is 3.90" on all models. Weight in pounds.

Stainless Steel Ordering Information

1/2 - 1.5 HP Single-Phase Units						
GPM	HP	Volt	Wire	Order No.	Model	Wt.
35	1/2	115	2	94743505	35FE05S4-2W115	25
	1/2	230	2	94743510	35FE05S4-2W230	25
	3/4	230	2	94743515	35FE07S4-2W230	29
	1	230	2	94743520	35FE1S4-2W230	33
	1.5	230	2	94743525	35FE15S4-2W230	39
45	1/2	115	2	94744505	45FE05S4-2W115	28
	1/2	230	2	94744510	45FE05S4-2W230	28
	3/4	230	2	94744515	45FE07S4-2W230	33
	1	230	2	94744520	45FE1S4-2W230	36
	1.5	230	2	94744525	45FE15S4-2W230	44
60	1/2	115	2	94746005	60FE05S4-2W115	29
	1/2	230	2	94746010	60FE05S4-2W230	29
	3/4	230	2	94746015	60FE07S4-2W230	33
	1	230	2	94746020	60FE1S4-2W230	37
	1.5	230	2	94746025	60FE15S4-2W230	45
90	1.5	230	2	94749025	90FE15S4-2W230	44

1/2 - 3 HP Pump Ends				
GPM	HP	Order No.	Model	Wt.
35	1/2	94753505	35FE05S4-PE	7
	3/4	94753510	35FE07S4-PE	8
	1	94753515	35FE1S4-PE	9
	1.5	94753520	35FE15S4-PE	10
	2	94753525	35FE2S4-PE	11
	3	94753530	35FE3S4-PE	12
45	1/2	94754505	45FE05S4-PE	10
	3/4	94754510	45FE07S4-PE	11
	1	94754515	45FE1S4-PE	12
	1.5	94754520	45FE15S4-PE	15
	2	94754525	45FE2S4-PE	16
	3	94754530	45FE3S4-PE	19
60	1/2	94756005	60FE05S4-PE	11
	3/4	94756010	60FE07S4-PE	12
	1	94756015	60FE1S4-PE	13
	1.5	94756020	60FE15S4-PE	14
	2	94756025	60FE2S4-PE	15
	3	94756030	60FE3S4-PE	17
90	1.5	94759020	90FE15S4-PE	15
	2	94759025	90FE2S4-PE	15
	3	94759030	90FE3S4-PE	17

Notes: Maximum diameter across cable guard is 3.90" on all models. Weight in pounds.

Discharge is 2" NPT with no built in check valve.

Submersible Pumps

E-Series Thermoplastic Pumps - 10 GPM

Capacities in U.S. Gallons per Minute

HP	PSI	Depth to Pumping Water Level, or Lift, in Feet. Shaded Areas Indicate Most Efficient Performance																	
		20	40	60	80	100	120	140	160	180	200	250	300	350	400	450	500	550	600
1/2	0			14	14	13	12	11	10	8	6								
	20	14	13	13	12	11	9	8	5										
	30	13	12	12	11	9	7	5											
	40	12	11	10	9	7	4												
	50	11	10	9	6	4													
	60	10	8	6	3														
	70	8	6	3															
	80	5																	
Shut-off PSI		96	87	79	70	61	53	44	35	27	18								
3/4	0			14	14	14	13	12	12	11	8	5							
	20			14	13	12	11	10	9	7	5	3							
	30		14	13	13	12	11	10	9	7	3								
	40	14	13	13	12	11	10	9	8	7	6								
	50	13	13	12	11	10	9	8	7	5	3								
	60	13	12	11	10	9	8	7	5	3									
	70	12	11	10	9	8	6	5											
	80	11	10	9	8	6	4												
Shut-off PSI		137	129	120	111	103	94	85	77	68	59	38	16						
1	0					14	14	14	13	13	11	9	7	5					
	20					14	13	13	12	11	9	8	5						
	30				14	14	13	13	12	11	10	9	7	3					
	40			14	13	13	12	12	11	10	10	8	5						
	50	14	14	13	13	12	12	11	10	9	9	7	4						
	60	14	13	13	12	12	11	10	9	9	8	6							
	70	13	13	12	11	11	10	9	8	8	7	4							
	80	13	12	11	11	10	9	8	8	7	6								
Shut-off PSI		182	174	165	156	148	139	130	122	113	105	83	61	40	18				
1.5	0						14	14	14	14	13	12	11	9	8	7	5		
	20						14	14	13	13	12	11	10	8	7	5			
	30						14	14	13	13	13	12	10	9	8	6	4		
	40				14	14	14	13	13	13	12	11	10	8	7	5			
	50			14	14	14	13	13	12	12	12	10	9	8	6	4			
	60		14	14	14	13	13	12	12	12	11	10	8	7	5	3			
	70	14	14	13	13	13	12	12	11	11	10	9	8	6	4				
	80	14	13	13	13	12	12	11	11	10	10	9	7	5	3				
Shut-off PSI		259	251	242	233	225	216	207	199	190	181	160	138	117	95	73	52	30	8

- Notes: 1. Performance shown does not include friction loss in the drop pipe.
 2. All performance data is based on rated motor nameplate voltage.

Submersible Pumps

E-Series Thermoplastic Pumps - 10 GPM

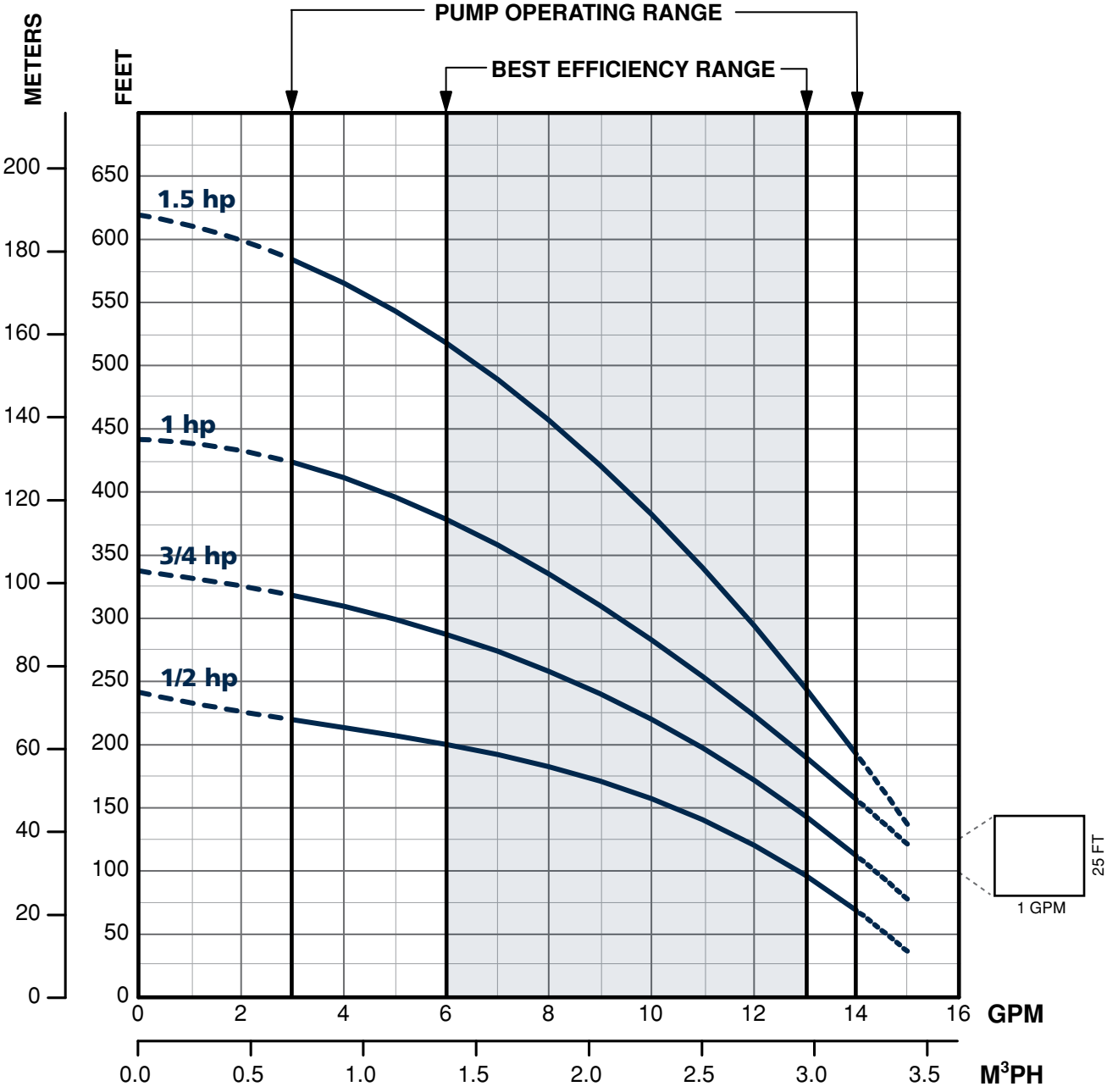

Submersible Pumps

E-Series Thermoplastic Pumps - 20 GPM

Capacities in U.S. Gallons per Minute

HP	PSI	Depth to Pumping Water Level, or Lift, in Feet. Shaded Areas Indicate Most Efficient Performance																	
		20	40	60	80	100	120	140	160	180	200	250	300	350	400	450	500	550	
1/2	0				26	22	18	9											Shut-off 152 ft
	20		24	21	16														
	30	24	21	15															
	40	20	13																
	50	12																	
	60																		
	70																		
	80																		
	Shut-off PSI		57	48	40	31	22	14	5										
3/4	0				27	25	22	19	15	7									Shut-off 191 ft
	20		26	24	21	18	13												
	30	26	24	21	18	12													
	40	23	20	17	11														
	50	20	16	9															
	60	15	8																
	70	6																	
	80																		
	Shut-off PSI		74	65	57	48	39	31	22	13	5								
1	0						26	25	23	20	18	6							Shut-off 251 ft
	20			27	26	24	22	20	18	15	8								
	30		27	26	24	22	19	17	14	7									
	40	27	25	23	21	19	17	13											
	50	25	23	21	19	16	12												
	60	23	21	18	16	11													
	70	20	18	15	10														
	80	18	15	9															
	Shut-off PSI		100	91	83	74	65	57	48	40	31	22	1						
1.5	0							27	26	24	21	17	9						Shut-off 379 ft
	20						27	25	24	23	21	17	10						
	30					26	25	24	22	21	20	15							
	40				26	25	23	22	21	19	18	11							
	50		27	26	25	23	22	21	19	17	15								
	60	27	26	24	23	22	20	19	17	15	11								
	70	26	24	23	21	20	19	17	14	11	5								
	80	24	23	21	20	18	16	14	10										
	Shut-off PSI		156	147	138	130	121	112	104	95	86	78	56	34	13				
2	0								27	27	24	21	17	12					Shut-off 452 ft
	20							27	26	25	24	21	18	13					
	30						27	26	25	24	23	19	16	9					
	40					27	26	25	24	23	21	18	13						
	50				27	26	25	24	22	21	20	16	10						
	60		27	27	26	25	23	22	21	19	18	14	5						
	70	27	27	26	24	23	22	21	19	18	16	10							
	80	26	25	24	23	22	20	19	18	16	14	6							
	Shut-off PSI		187	178	170	161	153	144	135	127	118	109	88	66	44	23			

- Notes:** 1. Performance shown does not include friction loss in the drop pipe.
 2. All performance data is based on rated motor nameplate voltage.

Submersible Pumps

E-Series Thermoplastic Pumps - 20 GPM

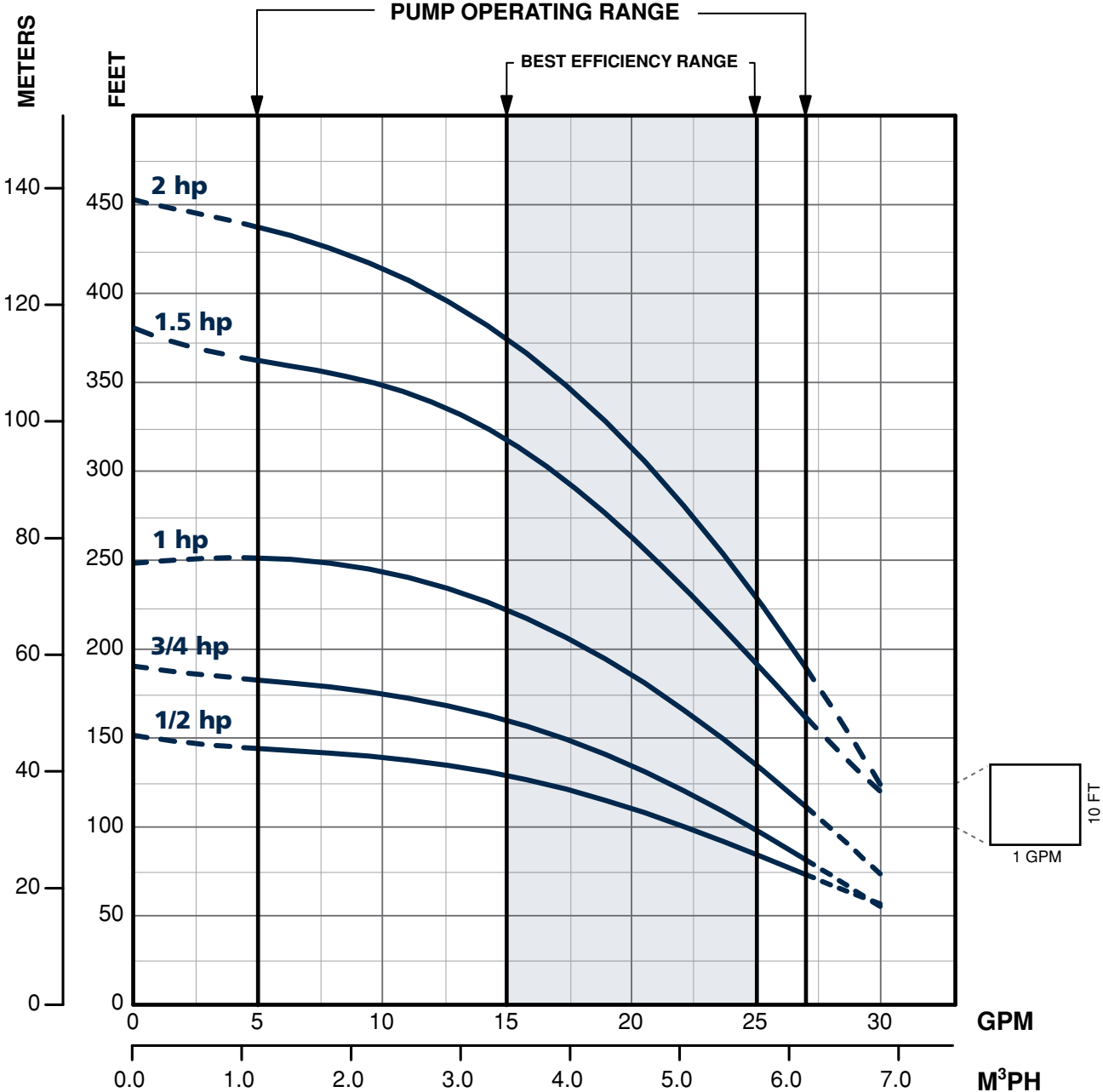

Submersible Pumps

E-Series Stainless Steel Pumps - 35 GPM

Capacities in U.S. Gallons per Minute

HP	PSI	Depth to Pumping Water Level, or Lift, in Feet. Shaded Areas Indicate Most Efficient Performance																
		20	40	60	80	100	120	140	160	180	200	250	300	350	400	450	500	550
1/2	0		40	30	15													
	10	38	29	11														
	20	27																
	30																	
	40																	
	50																	
Shut-off PSI		29	21	12	3													
3/4	0		42	36	28	17												
	10	42	35	27	14													
	20	33	25	11														
	30	24																
	40																	
	50																	
Shut-off PSI		40	32	23	14	6												
1	0			44	40	34	28	22	13									
	10		43	39	33	27	21	11										
	20	43	38	32	26	20												
	30	37	31	26	19													
	40	30	25	17														
	50	24	16															
	60	14																
Shut-off PSI		65	57	48	39	31	22	13	5									
1.5	0				43	40	36	31	27	23	18							
	10		45	42	39	35	31	27	23	16								
	20	45	42	38	34	30	26	22	15									
	30	41	38	34	30	26	21	13										
	40	37	33	29	25	20	12											
	50	32	28	24	19	10												
	60	28	24	18														
	70	23	17															
	80	16																
Shut-off PSI		89	81	72	63	55	46	37	29	20	11							
2	0				45	43	41	38	34	31	28	19						
	10			45	43	40	37	34	31	27	24	11						
	20		45	42	40	37	33	30	27	24	20							
	30	44	42	39	36	33	30	26	23	19	12							
	40	42	39	36	32	29	26	22	18	11								
	50	38	35	32	29	25	22	17	10									
	60	35	31	28	25	21	16											
	70	31	28	24	21	15												
	80	27	24	20	14													
Shut-off PSI		116	107	99	90	81	73	64	55	47	38	16						
3	0					45	44	42	40	38	32	26	18					
	10					45	44	42	40	38	36	29	23	12				
	20					45	44	42	40	38	35	27	19					
	30			45	43	42	39	37	35	32	30	24	13					
	40		45	43	41	39	37	34	32	30	27	20						
	50	44	43	41	39	36	34	32	29	27	24	14						
	60	43	41	38	36	34	31	29	26	24	21							
	70	40	38	36	33	31	28	26	23	20	15							
	80	38	35	33	30	28	26	23	19	15								
Shut-off PSI		163	154	145	137	128	119	111	102	94	85	63	42	20				

- Notes:** 1. Performance shown does not include friction loss in the drop pipe.
 2. All performance data is based on rated motor nameplate voltage.

Submersible Pumps

E-Series Stainless Steel Pumps - 35 GPM

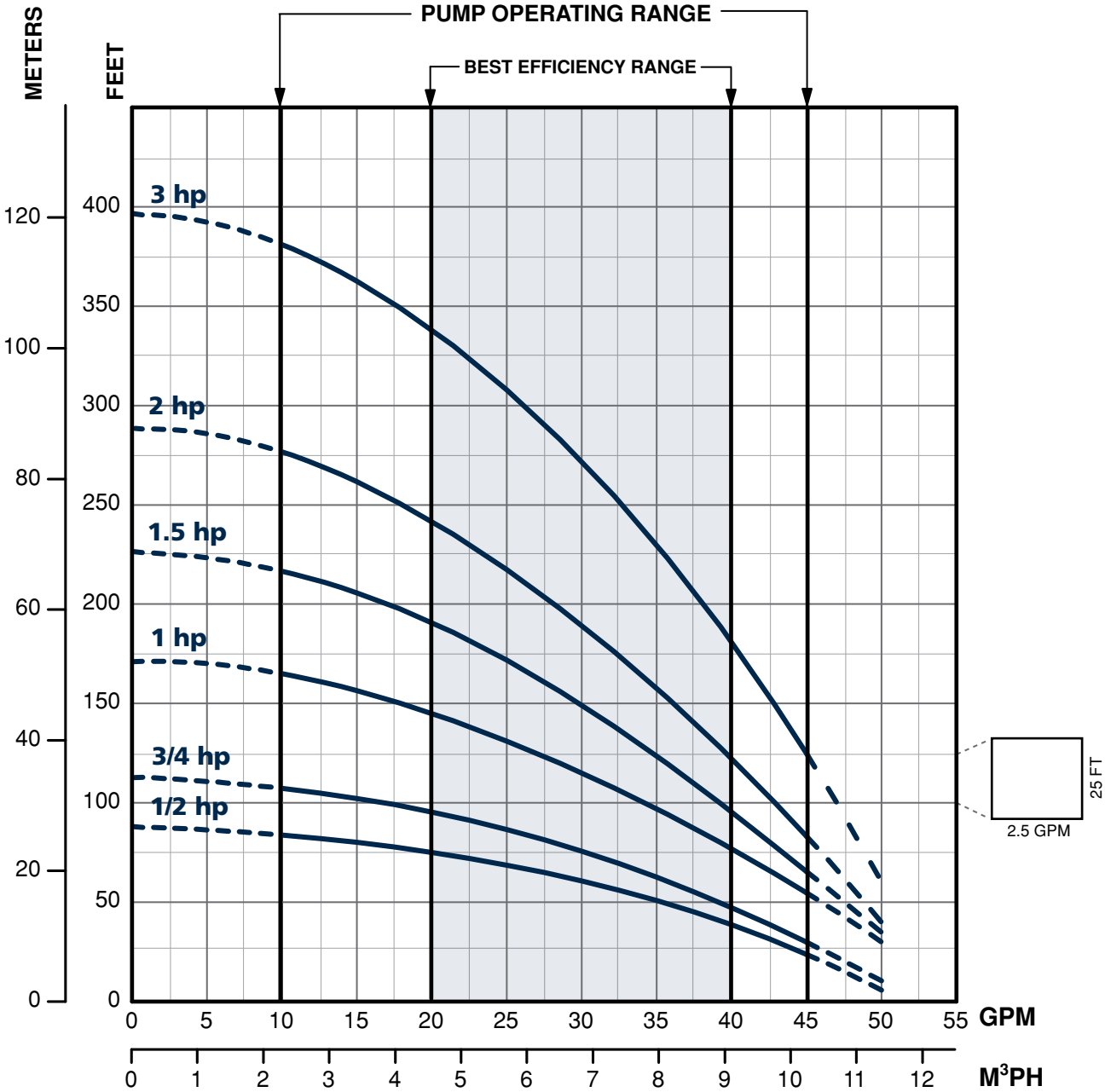

Submersible Pumps

E-Series Stainless Steel Pumps - 45 GPM

Capacities in U.S. Gallons per Minute

HP	PSI	Depth to Pumping Water Level, or Lift, in Feet. Shaded Areas Indicate Most Efficient Performance																		
		20	40	60	80	100	120	140	160	180	200	250	300	350	400	450	500		550	
1/2	0		40																	Shut-off 61 ft
	10	36																		
	20																			
	30																			
	40																			
	50																			
Shut-off PSI		18	9																	
3/4	0		52	43	33	21														Shut-off 122 ft
	10	51	42	32	18															
	20	40	30	16																
	30	28																		
	40																			
	50																			
Shut-off PSI		44	36	27	18	10														
1	0			52	45	37	27													Shut-off 158 ft
	10		51	43	35	25														
	20	49	42	34	23															
	30	41	32	21																
	40	31	20																	
	50	17																		
Shut-off PSI		60	51	43	34	25	17													
1.5	0				52	46	38	30	21											Shut-off 190 ft
	10		55	51	44	37	28	19												
	20	55	50	43	35	27	18													
	30	49	42	34	26	16														
	40	41	33	24																
	50	32	23																	
60	22																			
Shut-off PSI		74	65	56	48	39	30	22	13											
2	0				55	51	46	41	36	30	23									Shut-off 250 ft
	10			55	50	45	40	35	29	22										
	20		54	49	44	39	34	28	21											
	30	53	49	44	38	33	27	19												
	40	48	43	38	32	26	18													
	50	42	37	31	24	17														
60	36	30	23	16																
Shut-off PSI		99	91	82	73	65	56	48	39	30	22									
3	0					56	53	49	46	42	38	27								Shut-off 337 ft
	10				55	52	49	45	41	37	33	21								
	20			55	52	48	45	41	37	32	28									
	30		54	51	48	44	40	36	32	27	22									
	40	54	51	47	44	40	35	31	26	21	15									
	50	50	47	43	39	35	30	25	20											
	60	46	42	38	34	30	25	19												
	70	42	38	33	29	24	18													
	80	37	33	28	23	17														
	90	32	27	22	16															
	100	27	21	16																
Shut-off PSI		137	129	120	111	103	94	85	77	68	59	38								

- Notes:** 1. Performance shown does not include friction loss in the drop pipe.
 2. All performance data is based on rated motor nameplate voltage.

Submersible Pumps

E-Series Stainless Steel Pumps - 45 GPM

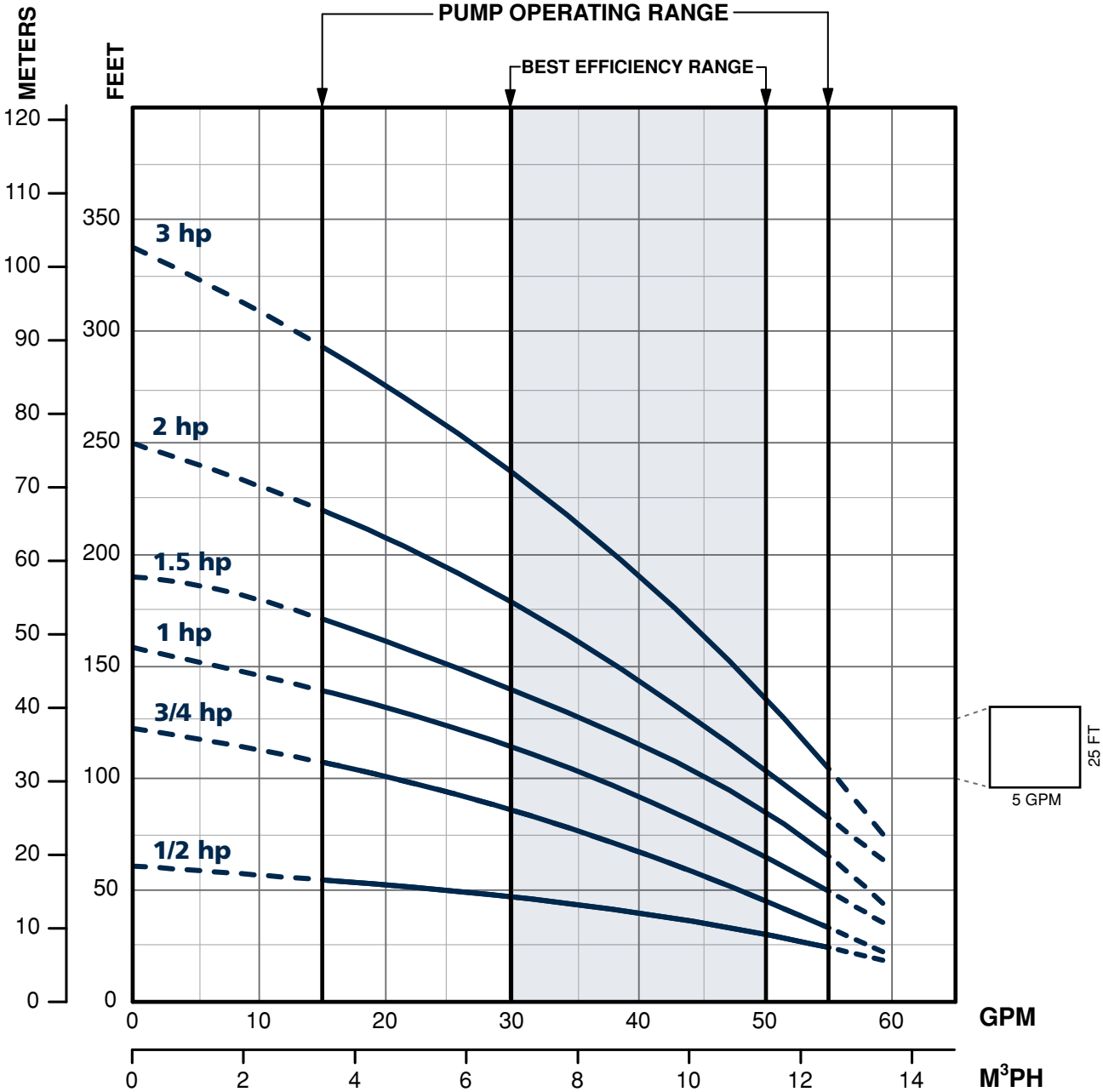

Submersible Pumps

E-Series Stainless Steel Pumps - 60 GPM

Capacities in U.S. Gallons per Minute

HP	PSI	Depth to Pumping Water Level, or Lift, in Feet. Shaded Areas Indicate Most Efficient Performance																
		20	40	60	80	100	120	140	160	180	200	250	300	350	400	450	500	550
1/2	0	68	44															
	10	39																
	20																	
	30																	
	40																	
	50																	
Shut-off PSI		17	8															
3/4	0		64	47														
	10	62	43															
	20	40																
	30																	
	40																	
	50																	
Shut-off PSI		31	22	14														
1	0		70	58	42													
	10	68	56	39														
	20	54	35															
	30	31																
	40																	
	50																	
Shut-off PSI		41	32	23	15													
1.5	0			69	61	51	34											
	10		67	59	49	31												
	20	66	58	47	27													
	30	57	44	24														
	40	42	20															
	50																	
Shut-off PSI		56	47	39	30	21	13											
2	0				66	57	47	34	21									
	10		72	65	56	45	32											
	20	71	64	54	43	30												
	30	62	53	41	28													
	40	51	39	26														
	50	37	24															
	60	22																
Shut-off PSI		76	67	58	50	41	32	24	15									
3	0					70	65	60	53	46	37							
	10					70	64	59	52	45	36	25						
	20			69	64	58	51	43	34	24								
	30		68	63	57	50	42	33	22									
	40	67	62	56	49	41	31	20										
	50	61	55	48	39	29												
	60	54	46	38	28													
Shut-off PSI		106	98	89	80	72	63	54	46	37	28							

- Notes:** 1. Performance shown does not include friction loss in the drop pipe.
 2. All performance data is based on rated motor nameplate voltage.

Submersible Pumps

E-Series Stainless Steel Pumps - 60 GPM

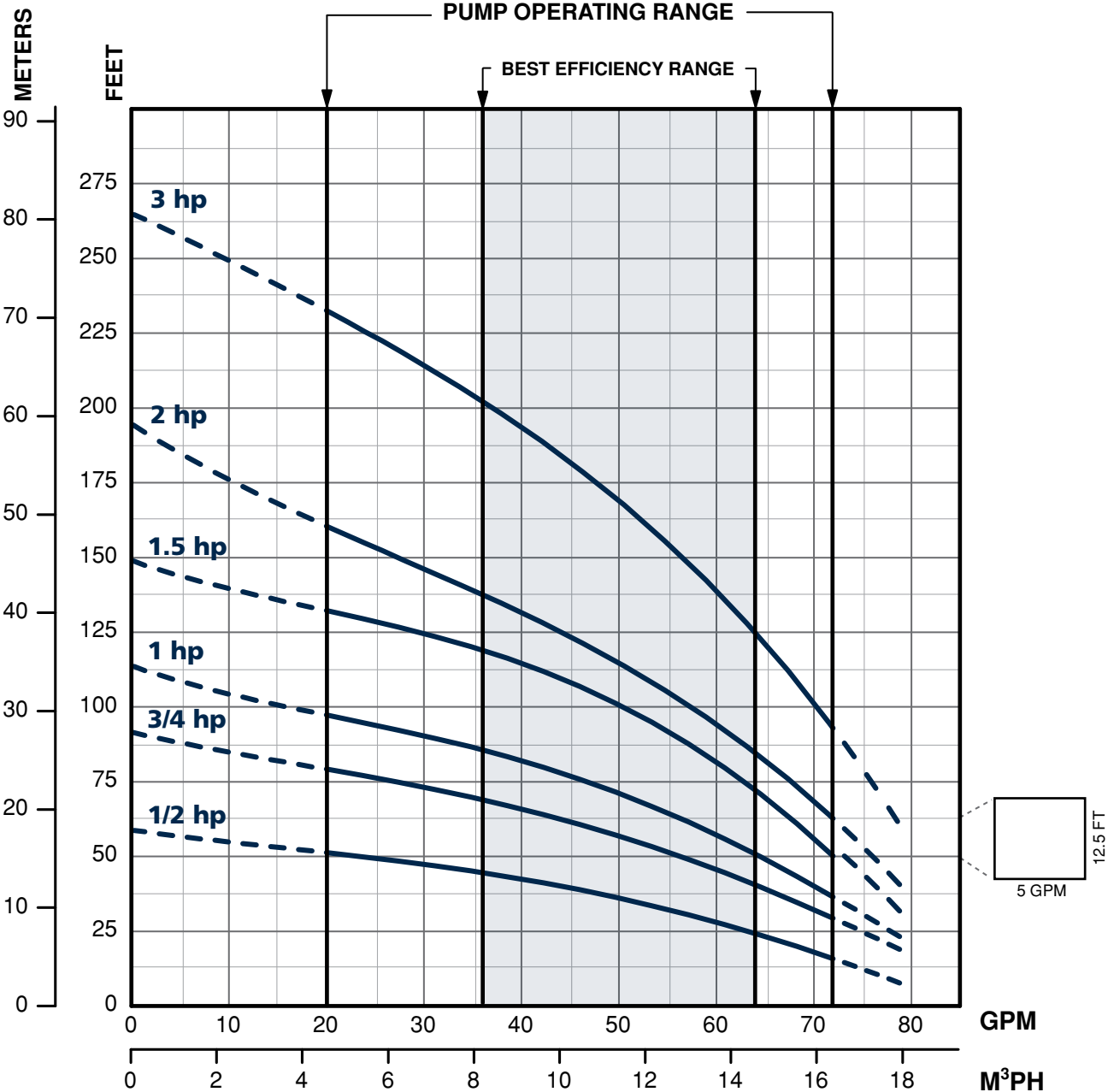

Submersible Pumps

E-Series Stainless Steel Pumps - 90 GPM

Capacities in U.S. Gallons per Minute

HP	PSI	Depth to Pumping Water Level, or Lift, in Feet. Shaded Areas Indicate Most Efficient Performance																		
		20	40	60	80	100	120	140	160	180	200	250	300	350	400	450	500		550	
1.5	0		99	69	43														Shut-off 95 ft	
	10	94	65	38																
	20	61	32																	
	30																			
	40																			
	50																			
Shut-off PSI		32	24	15	6															
2	0		112	91	68	47													Shut-off 121 ft	
	10	109	88	65	43															
	20	84	61	39																
	30	58	34																	
	40																			
	50																			
Shut-off PSI		44	35	26	18	9														
3	0			110	96	79	64	48											Shut-off 167 ft	
	10		108	93	77	61	45													
	20	106	91	74	59	42														
	30	88	72	57	38															
	40	69	54	34																
	50	52	30																	
Shut-off PSI		64	55	46	38	29	20	12												

- Notes:** 1. Performance shown does not include friction loss in the drop pipe.
 2. All performance data is based on rated motor nameplate voltage.

Submersible Pumps

E-Series Stainless Steel Pumps - 90 GPM

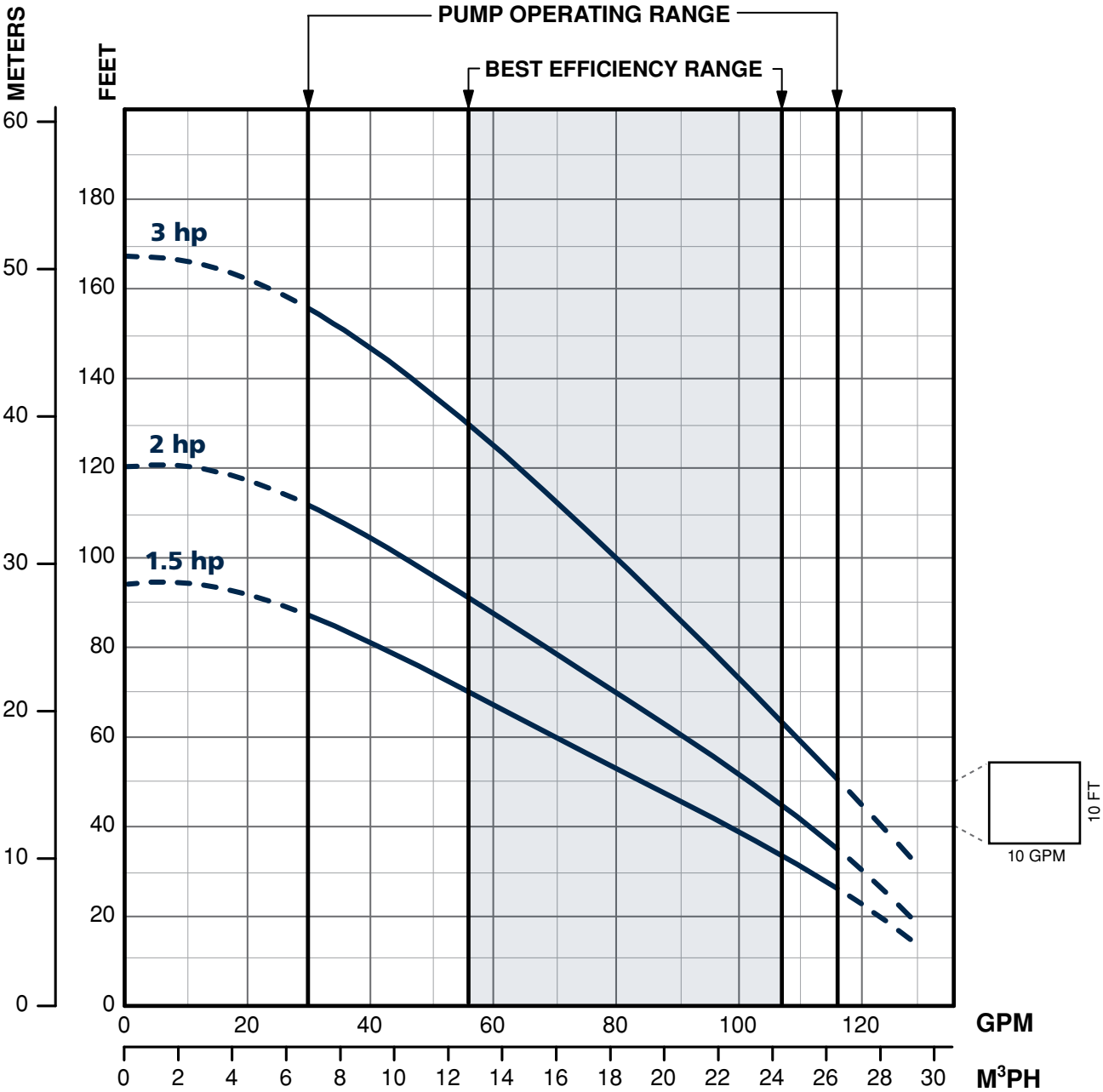

Submersible Pumps

C1 Series Cistern Pumps - Features



C1 SERIES

Designed for use in gray water / filtered effluent service applications, the C1 Series cistern pump provides high performance and long life in less than ideal water conditions. The C1 Series pump is able to pass solids up to 1/8" without having a negative effect on the internal hydraulic components.

The pump's unique bottom suction design allows for maximum fluid drawdown without compromising durability or overall life, and it does not require the use of a flow induction sleeve. Intended specifically for use in a cistern or tank, C1 Series pumps are suitable for use in agricultural, residential, and commercial installations.

Applications:

- Gray water pumping.
- Filtered effluent service water pumping.
- Water reclamation projects such as pumping from rain catchment basins.
- Aeration and other fountain or pond applications.
- Agriculture and livestock water pumping.

Features:

- Supplied with a removable 5" base for secure and reliable mounting.
- Bottom suction design.
- Robust thermoplastic discharge head design resists breakage during installation and operation.
- Single shell housing design provides a compact unit while ensuring cool and quiet operation.
- Hydraulic components molded from high quality engineered thermoplastics.
- Optimized hydraulic design allows for increased performance and decreased power usage.
- All metal components are made of high grade stainless steel for corrosion resistance.
- Available with a high quality 115 V or 230, 1/2 hp motor.
- Fluid flows of 10, 20, and 30 gpm, with a maximum shut-off pressure of 100 psi.
- Heavy duty 600 V 10 foot SJOOW jacketed lead.

Submersible Pumps

C1 Series - Ordering Information

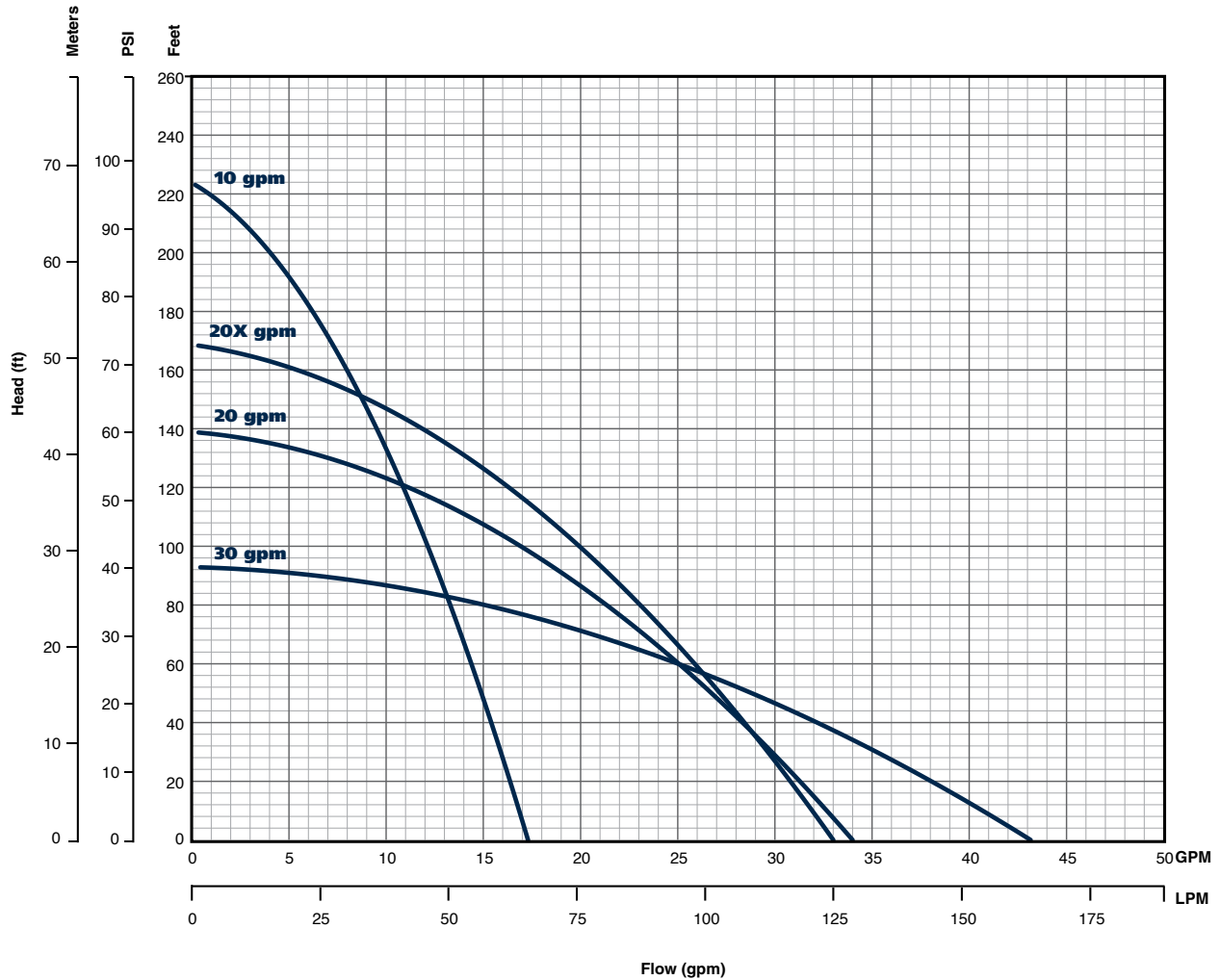

Ordering Information

FPS C1 Series Pumps							
GPM	HP	Volts	Stage	Model No.	Order No.	Length (in.)	Weight (lbs.)
10	1/2	115	7	10C1-05P4-2W115	90301005	26	17
		230	7	10C1-05P4-2W230	90301010	26	17
20		115	5	20C1-05P4-2W115	90302005	25	16
		230	5	20C1-05P4-2W230	90302010	25	16
20X		115	6	20XC1-05P4-2W115	90302015	26	17
		230	6	20XC1-05P4-2W230	90302020	26	17
30		115	4	30C1-05P4-2W115	90303005	25	16
		230	4	30C1-05P4-2W230	90303010	25	16

Note: All units have 10 foot long SJOOW leads.

Submersible Pumps

Accessories - Ordering Information



Check Valves



Poppet



Reducer Bushing



T-Handle Poppet Wrench

Check Valves - Silicone Bronze

Description	Inlet	Outlet	Case Qty.	Order No.	Wt.
Flomatic™ 4221LEB	1-1/4" MNPT	1" FNPT	36	91980631	1.25
Flomatic™ 4242LEB	1-1/4" MNPT	1-1/4" FNPT	36	91980649	1.75

Check Valves - Stainless Steel

Description	Inlet	Outlet	Case Qty.	Order No.	Wt.
Flomatic™ #4221LSS2	1-1/4" MNPT	1" FNPT	49	91985317	1.4
Flomatic™ #4242SS2	1-1/4" MNPT	1-1/4" FNPT	49	91985309	1.5

Check Valves - Ductile Iron

Description	Inlet	Outlet	Carton Qty.	Order No.	Wt.
Simmons #658SB	2" MNPT	2" FNPT	1	91982157	3.5
Simmons #660SB	3" MNPT	3" FNPT	1	91981266	10
Simmons #661SB	4" MNPT	4" FNPT	1	91980334	21

Flomatic™ Poppet with Removable Ring (Patent Pending)

Description	Order No.	Wt.
Flomatic™ Poppet with Removable Ring (Patent Pending)	91985259R	0.1
T-Handle Poppet Wrench	23498207	1

Reducer Bushing

Description	Inlet	Outlet	PSI Rating	Order No.	Wt.
White PVC Bushing	1-1/4" MNPT	1" FNPT	200 PSI	31031008R	0.2

Note: Flomatic™ is a trademark of the Danfoss Corporation.

Non-Submersible Pumps

VersaJet Pro Shallow Well Jet Pumps - Features

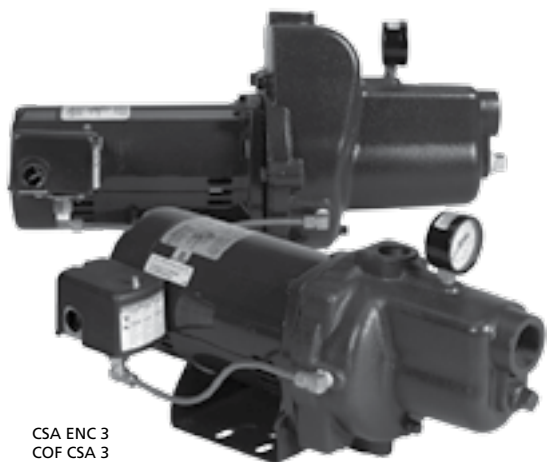

CSA ENC 3
COF CSA 3



Features:

- Impeller with corrosion-resistant stainless steel insert, diffuser, jet nozzle, and venturi are all molded with Noryl®. Noryl® thermoplastic is a highly efficient, dependable material known for its exceptional performance when used to produce hydraulic components for water systems.
- Heavy-duty cast iron case ensures optimum durability and long life.
- Floating stainless steel eye seal for maximum performance and efficiency.
- Powered by high quality, industry proven, UL778 approved indoor/outdoor square flange motors.
- Revolutionary “Quick-Change” jet nozzle replacement system allows easy customization of the pump. Performance can be changed quickly from a high pressure to a high flow set-up without removing the plumbing or opening the case.
- Easily adjustable dual voltage motor can be set to run at either 115 V or 230 V.
- Professional grade 30/50 pressure switch with copper hose is adjustable in both the differential and the range.
- Built-in drain plug for easy winterizing and servicing.
- Handles water temperatures up to 120 °F/49 °C and shut-off pressures up to 90 psi.
- 1” NPT discharge, 1-1/4” NPT suction.
- UL778 certified for indoor or outdoor use.

Noryl® is a registered trademark of G.E.



*Revolutionary
“Quick Change” Jet Nozzle*

Ordering Information (See pgs. 2-3 for model number explanation)

Model	HP	Discharge x Suction	Voltage	Pump Unit	
				Order No.	Wt.
FVJ05CI-P	1/2	1" x 1-1/4"	115/230	91181005	34
FVJ07CI-P	3/4	1" x 1-1/4"	115/230	91181007	51
FVJ1CI-P	1	1" x 1-1/4"	115/230	91181010	56

Non-Submersible Pumps

VersaJet Pro Shallow Well Jet Pumps

Performance Chart

VJ 1" Discharge x 1-1/4" Suction			Discharge Pressure - PSI						Shut-off Pressure PSI
Model	Nozzle	Total Suction Lift Ft	10	20	30	40	50	60	
			Gallons per Minute						
FVJ05CI-P	Nozzle C (Standard)	5	16.3	15.6	15.1	14.1	9.0	3.8	70
		10	14.2	13.6	13.1	12.5	7.8	2.9	
		15	12.1	11.6	11.2	10.8	6.5	2.0	
		20	9.5	9.1	8.9	8.7	5.0	1.0	
		25	7.0	6.7	6.7	6.6	3.5	-	
	Nozzle D (High Pressure)	5	15.8	15.2	14.7	14.1	9.6	4.8	73
		10	13.9	13.2	12.8	12.4	8.5	3.9	
		15	11.9	11.1	10.8	10.6	7.5	3.0	
		20	9.2	8.8	8.6	8.5	6.2	1.8	
		25	6.5	6.5	6.4	6.4	4.8	0.6	
	Nozzle A (High Flow)	5	18.9	18.7	18.4	11.6	-	-	47
		10	16.8	16.6	16.3	8.0	-	-	
15		14.8	14.5	14.2	4.4	-	-		
20		11.8	11.6	11.2	2.2	-	-		
25		8.8	8.7	8.1	-	-	-		
FVJ07CI-P	Nozzle B (Standard)	5	21.5	21.0	20.7	20.4	12.8	3.9	64
		10	19.2	18.8	18.5	18.2	11.3	2.0	
		15	16.9	16.6	16.3	16.0	9.7	-	
		20	13.6	13.4	13.2	13.0	7.4	-	
		25	10.4	10.3	10.1	10.0	5.0	-	
	Nozzle C (High Pressure)	5	20.4	19.8	19.4	19.1	14.6	7.7	71
		10	18.1	17.6	17.3	17.1	13.6	6.5	
		15	15.9	15.4	15.2	15.0	12.6	5.2	
		20	12.7	12.4	12.2	12.1	10.8	3.3	
		25	9.5	9.3	9.2	9.1	9.0	1.4	
	Nozzle A (High Flow)	5	23.3	23.0	22.7	20.2	7.6	-	54
		10	20.7	20.3	20.0	17.4	3.8	-	
15		18.1	17.7	17.3	14.6	-	-		
20		14.8	14.5	14.2	10.8	-	-		
25		11.5	11.3	11.1	7.0	-	-		
FVJ1CI-P	Nozzle B (Standard)	5	29.0	28.6	28.2	27.8	24.0	11.6	66
		10	25.5	25.0	24.8	24.5	21.2	7.7	
		15	21.9	21.5	21.3	21.1	18.5	3.8	
		20	17.6	17.2	16.9	16.7	13.8	1.9	
		25	13.2	12.9	12.6	12.3	9.2	-	
	Nozzle C (High Pressure)	5	28.7	28.2	27.9	27.6	26.8	15.5	72
		10	25.3	24.8	24.4	24.0	23.4	13.3	
		15	21.9	21.4	20.9	20.5	20.1	11.2	
		20	17.4	17.1	16.8	16.6	16.3	7.0	
		25	13.0	12.9	12.7	12.6	12.5	2.8	
	Nozzle A (High Flow)	5	30.3	29.9	29.5	29.2	19.5	-	59
		10	26.9	26.6	26.2	25.9	15.9	-	
15		23.6	23.3	22.9	22.6	12.4	-		
20		19.0	18.8	18.5	17.9	6.2	-		
25		14.5	14.3	14.1	13.2	-	-		

Non-Submersible Pumps

VersaJet Shallow Well Jet Pumps - Features



CSA ENC 3
COF CSA 3



Features:

- Impeller with stainless steel insert, diffuser, jet nozzle, and venturi are all molded with Noryl®. Noryl® thermoplastic is a proven dependable material known for its properties to increase efficiency and hydraulic performance.
- Heavy-duty cast iron case ensures optimum durability and long life.
- Floating stainless steel eye seal for maximum performance and efficiency.
- Powered by high quality, industry proven, UL778 approved indoor/outdoor square flange motors.
- Revolutionary “Quick-Change” jet nozzle replacement system allows easy customization of the pump. Performance can be changed quickly from a high pressure to a high flow set-up without removing the plumbing or opening the case.
- Dual voltage motor can be set to run at either 115 V or 230 V.
- Pressure switch is installed and set at 30/50 PSI.
- Built-in drain plug for easy winterizing and servicing.
- Handles water temperatures up to 120 °F/49 °C and shut-off pressures up to 90 psi.
- 1” NPT discharge, 1-1/4” NPT suction.
- UL778 approved for indoor or outdoor use.

Noryl® is a registered trademark of G.E.



Revolutionary
“Quick Change” Jet Nozzle

Ordering Information (See pgs. 2-3 for model number explanation)

Model	HP	Discharge x Suction	Voltage	Pump Unit	
				Order No.	Wt.
FVJ05CI	1/2	1" x 1-1/4"	115/230	91180005	31
FVJ07CI	3/4	1" x 1-1/4"	115/230	91180007	34
FVJ1CI	1	1" x 1-1/4"	115/230	91180010	51
FVJ15CI	1.5	1" x 1-1/4"	115/230	91180015	56

Non-Submersible Pumps

VersaJet Shallow Well Jet Pumps

Performance Chart

VJ 1" Discharge x 1-1/4" Suction			Discharge Pressure - PSI						Shut-off Pressure PSI
Model	Nozzle	Total Suction Lift Ft	10	20	30	40	50	60	
			Gallons per Minute						
FVJ05CI	Nozzle B (Standard)	5	10.8	10.5	10.1	8.5	4.9	2.1	70
		10	9.4	9.1	8.7	7.5	4.1	1.6	
		15	8.0	7.7	7.4	6.5	3.4	1.1	
		20	6.2	6.0	5.7	5.3	2.6	0.5	
	Nozzle C (High Pressure)	25	4.4	4.3	4.1	4.0	1.8	-	86
		5	9.8	8.9	8.3	7.6	6.3	4.0	
		10	8.3	7.5	7.1	6.6	5.7	3.5	
		15	6.8	6.2	5.9	5.7	5.1	3.0	
	Nozzle A (High Flow)	20	5.3	5.0	4.8	4.6	4.3	2.6	47
		25	3.8	3.8	3.7	3.6	3.5	2.2	
		5	12.8	12.5	12.1	5.2	-	-	
		10	11.4	11.1	10.8	3.6	-	-	
FVJ07CI	Nozzle C (Standard)	15	10.0	9.8	9.6	1.9	-	-	70
		20	8.0	7.7	6.8	1.0	-	-	
		25	6.0	5.7	4.1	-	-	-	
		5	16.3	15.6	15.1	14.1	9.0	3.8	
	Nozzle D (High Pressure)	10	14.2	13.6	13.1	12.5	7.8	2.9	73
		15	12.1	11.6	11.2	10.8	6.5	2.0	
		20	9.5	9.1	8.9	8.7	5.0	1.0	
		25	7.0	6.7	6.7	6.6	3.5	-	
	Nozzle A (High Flow)	5	15.8	15.2	14.7	14.1	9.6	4.8	47
		10	13.9	13.2	12.8	12.4	8.5	3.9	
		15	11.9	11.1	10.8	10.6	7.5	3.0	
		20	9.2	8.8	8.6	8.5	6.2	1.8	
FVJ1CI	Nozzle B (Standard)	25	6.5	6.5	6.4	6.4	4.8	0.6	64
		5	18.9	18.7	18.4	11.6	-	-	
		10	16.8	16.6	16.3	8.0	-	-	
		15	14.8	14.5	14.2	4.4	-	-	
	Nozzle C (High Pressure)	20	11.8	11.6	11.2	2.2	-	-	71
		25	8.8	8.7	8.1	-	-	-	
		5	21.5	21.0	20.7	20.4	12.8	3.9	
		10	19.2	18.8	18.5	18.2	11.3	2.0	
	Nozzle A (High Flow)	15	16.9	16.6	16.3	16.0	9.7	-	54
		20	13.6	13.4	13.2	13.0	7.4	-	
		25	10.4	10.3	10.1	10.0	5.0	-	
		5	20.4	19.8	19.4	19.1	14.6	7.7	
FVJ15CI	Nozzle B (Standard)	10	18.1	17.6	17.3	17.1	13.6	6.5	66
		15	15.9	15.4	15.2	15.0	12.6	5.2	
		20	12.7	12.4	12.2	12.1	10.8	3.3	
		25	9.5	9.3	9.2	9.1	9.0	1.4	
	Nozzle C (High Pressure)	5	23.3	23.0	22.7	20.2	7.6	-	72
		10	20.7	20.3	20.0	17.4	3.8	-	
		15	18.1	17.7	17.3	14.6	-	-	
		20	14.8	14.5	14.2	10.8	-	-	
	Nozzle A (High Flow)	25	11.5	11.3	11.1	7.0	-	-	59
		5	29.0	28.6	28.2	27.8	24.0	11.6	
		10	25.5	25.0	24.8	24.5	21.2	7.7	
		15	21.9	21.5	21.3	21.1	18.5	3.8	
Nozzle C (High Pressure)	20	17.6	17.2	16.9	16.7	13.8	1.9	72	
	25	13.2	12.9	12.6	12.3	9.2	-		
	5	28.7	28.2	27.9	27.6	26.8	15.5		
	10	25.3	24.8	24.4	24.0	23.4	13.3		
Nozzle A (High Flow)	15	21.9	21.4	20.9	20.5	20.1	11.2	59	
	20	17.4	17.1	16.8	16.6	16.3	7.0		
	25	13.0	12.9	12.7	12.6	12.5	2.8		
	5	30.3	29.9	29.5	29.2	19.5	-		
Nozzle C (High Pressure)	10	26.9	26.6	26.2	25.9	15.9	-	59	
	15	23.6	23.3	22.9	22.6	12.4	-		
	20	19.0	18.8	18.5	17.9	6.2	-		
	25	14.5	14.3	14.1	13.2	-	-		

Non-Submersible Pumps

VersaJet Series Shallow Well Jet Pumps

Dimensional Data

1/2 and 3/4 Hp VersaJet AND 1/2 Hp VersaJet Pro

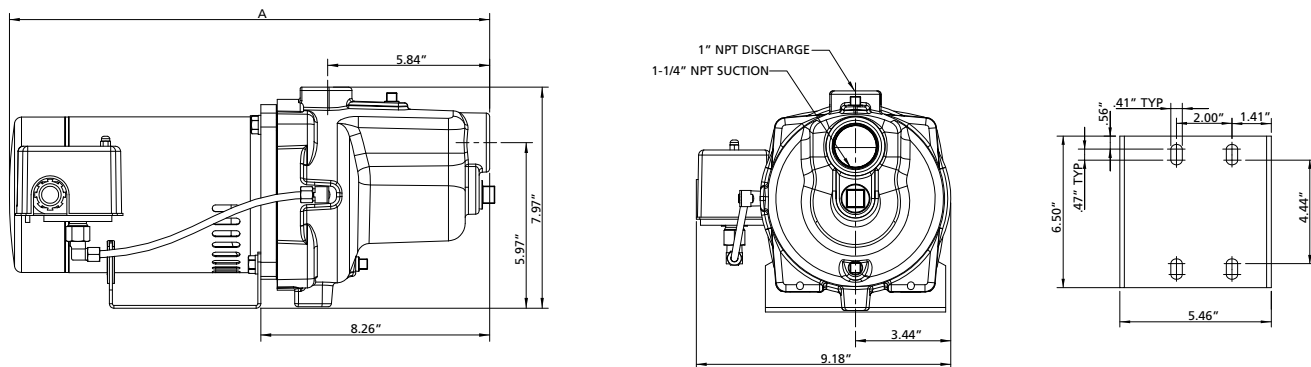

1 and 1.5 Hp VersaJet AND 3/4 and 1 Hp VersaJet Pro

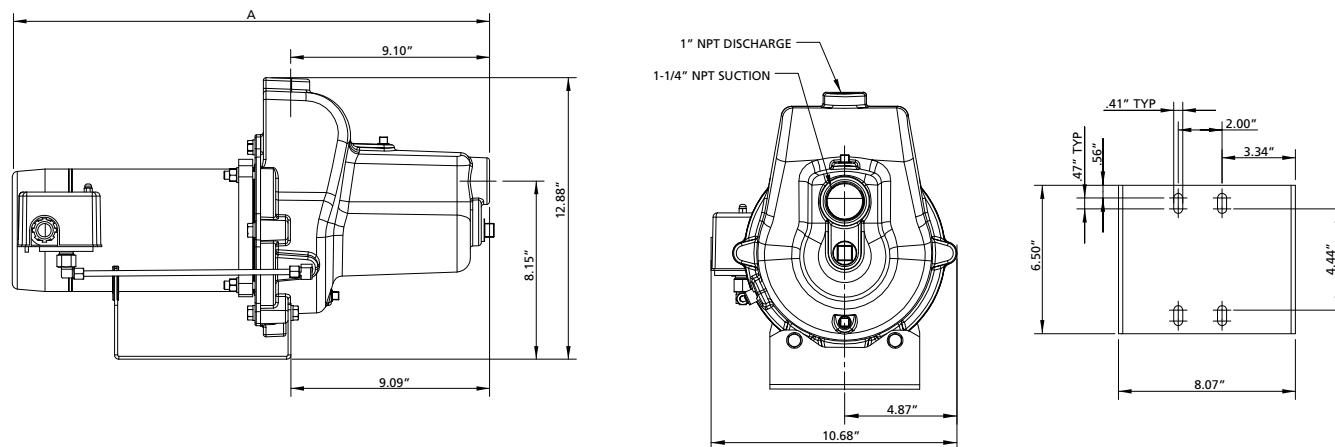

VersaJet Dimensions	
HP	A
1/2	17.25"
3/4	18.00"
1	21.78"
1.5	22.66"

VersaJet Pro Dimensions	
HP	A
1/2	18.00"
3/4	21.78"
1	22.66"

Note: Dimensions will vary according to motor manufacturer.

Non-Submersible Pumps

SWJ Series Pumps - Features



CSA ENC 3
COF CSA 3



CSA 108
UL 778

SWJ Series

Features:

- Non-corrosive thermoplastic construction.
- Replaceable in-line nozzle/venturi design for maximum hydraulic efficiency and ease of service.
- Self cleaning, anti-clogging injector screen.
- Thermoplastic impeller and diffuser ensure increased hydraulic performance.
- Floating stainless steel eye seal for maximum performance and efficiency.
- Square-flange mounting provides easy serviceability without disturbing the plumbing.
- Built-in drain plug for easy winterizing and servicing.
- Mechanical shaft seal allows positive protection against leaking.
- Order pressure gauge separately.
- Pressure switch is installed and set at 30/50 psi.
- Handles water temperatures up to 120 °F/49 °C and working pressure up to 75 psi.
- Connections:
1-1/4" NPT suction
1" NPT discharge

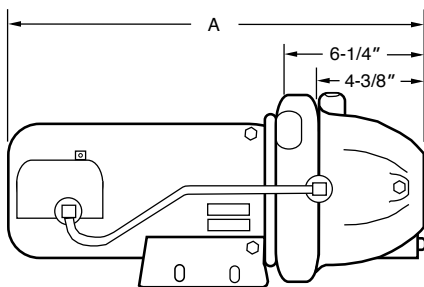
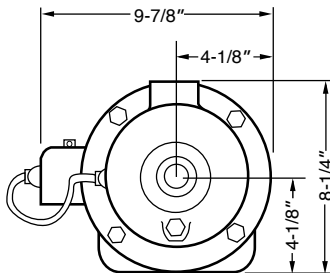

Dimensions		
Series	HP	A
FSWJ05P	1/2	17-5/8"
FSWJ07P	3/4	18-1/4"

Note: Dimensions will vary according to motor manufacturer.

Non-Submersible Pumps

SWJ Series Pumps - Ordering Information

(See pgs. 2-3 for model number explanation)

Plastic Pump Body					
Model	HP	Discharge x Suction	Voltage	Pump Unit	
				Order No.	Wt.
FSWJ05P	1/2	1" x 1-1/4"	115/230	91090005	23
FSWJ07P	3/4	1" x 1-1/4"	115/230	91090007	31

Note: Weight in pounds.

HP	Total Suction Lift Ft	Discharge Pressure - PSI								Shut-off Pressure PSI
		30	35	40	45	50	55	60	65	
		Gallons per Minute								
1/2	5	12.0	10.7	9.1	7.2	4.9	2.8	0.9	-	62
	10	-	10.0	8.4	6.3	3.9	1.9	-	-	60
	15	-	-	7.7	5.3	3.0	0.9	-	-	57
	20	-	-	6.4	4.3	2.2	0.2	-	-	55
	25	-	-	5.0	3.3	1.4	-	-	-	53
3/4	5	-	16.0	14.4	12.6	10.6	8.3	5.0	1.8	68
	10	-	-	13.5	11.8	9.7	6.9	3.6	0.2	65
	15	-	-	-	11.0	8.8	5.4	2.2	-	63
	20	-	-	-	9.0	7.2	3.9	0.8	-	60
	25	-	-	-	-	5.6	2.3	-	-	58

Non-Submersible Pumps

Convertible VersaJet Pro Series Jet Pumps - Features

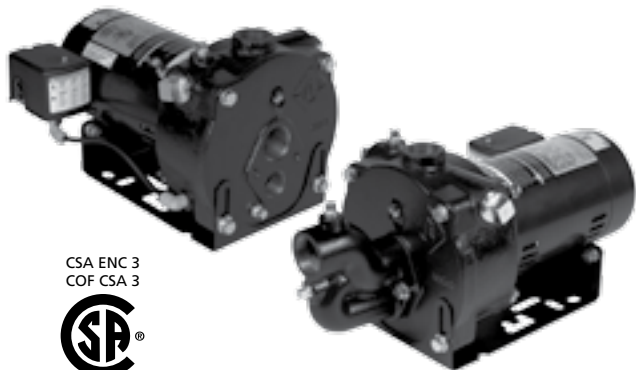

CSA ENC 3
COF CSA 3



Although no single pump can meet all applications, the Convertible VersaJet from Franklin Electric comes close. Each model can be configured with a variety of pressure and flow choices in both shallow and deep set installations. In addition, four different suction flange options make this pump the contractor's choice for those tough replacement jobs.

Features:

- Heavy-duty cast iron case ensures optimum durability and long life.
- Modular suction flange system to retrofit current installations without disturbing the existing plumbing.
- Thermoplastic impeller and diffuser precision molded for high efficiency and dependability.
- Thermoplastic impeller and diffuser ensure increased hydraulic performance.
- Phenolic/Ceramic mechanical shaft seal ensures leakproof fit and maximum pressure handling capability.
- Adjustable pressure switch is factory set at 30/50 psi.
- Powered by high quality, industry proven, UL778 approved indoor/outdoor square flange motors.
- Dual voltage motor can be set to run at either 115 V or 230 V.
- Built in drain plug for easy winterization and servicing.
- Pressure gauge supplied for easy monitoring of system pressure.
- Connections:
1-1/4" FNPT Suction
1" FNPT Discharge
1" FNPT Drive Line

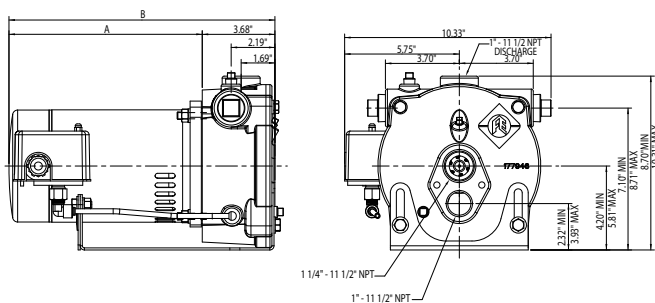

Dimensional illustration shown with K1-S flange installed.

Dimensions:

HP	A	B
1/2	10.38	14.06
3/4	11.00	13.68
1	11.88	15.56

Ordering Information:

Model No.	HP	Discharge x Suction	Voltage	Pump (without flange kit)		Pump, Injector, and Flange			
				Order No.	Wt.	Shallow Well Kits		Deep Well Kits	
						Order No.	Wt.	Order No.	Wt.
FCVJ05CI-P	1/2	1" x 1-1/4"	115/230	96131005	39.3	96131005SW	51	96131005DW	52
FCVJ07CI-P	3/4	1" x 1-1/4"	115/230	96131007	41.6	96131007SW	54	96131007DW	55
FCVJ10CI-P	1	1" x 1-1/4"	115/230	96131010	46.0	96131010SW	58	96131010DW	59

- Notes:**
1. Order suction flange kit A, or shallow well kit B, or deep well kit C depending upon application.
 2. Minimum inside well diameter requirement of 4" for deep well injectors.
 3. Control valve required for deep well installations.

Non-Submersible Pumps

Convertible VersaJet Pro Series Jet Pumps

Shallow Well Performance

CVJ Pro Series			Discharge Pressure - PSI						Shut-off Pressure PSI
HP	Injector Kit	Suction Lift Ft	30	40	50	60	70	80	
			Gallons per Minute						
1/2	SW5 96151005	5							
		10	16.7	14.0	8.2	2.8			65
		15		12.7	6.8	1.6			63
		20		11.3	5.7				61
		25		8.8	4.6				59
	SW6 96151006	5	11.8	11.8	8.6	5.3	2.9	0.8	85
		10		10.2	7.8	4.7	2.5		83
		15		8.7	7.0	4.2	2.2		81
		20		7.1	6.2	3.8	1.7		79
		25			5.5	3.4	1.2		77
	SW7 96151007	5		8.2	7.9	5.7	3.8	2.4	101
		10		7.1	6.9	5.3	3.6	2.2	99
		15			6.1	4.8	3.3	1.9	97
		20			5.1	4.4	3.1	1.7	95
		25			4.1	4.0	2.7	1.4	93
3/4	SW4 96151004	5	21.4	18.6	11.8	5.2			68
		10	18.8	17.1	10.4	3.8			66
		15	16.2	15.4	8.9	2.4			64
		20	13.4	13.4	7.5	0.8			61
		25	10.5	10.5	6.2				59
	SW5 96151005	5	18.7	18.5	13.0	7.7	2.8		76
		10		16.4	11.8	6.6	1.6		73
		15		14.2	10.7	5.4			71
		20		11.6	9.5	4.5			69
		25		9.0	8.4	3.6			67
	SW6 96151006	5		11.7	11.1	7.8	5.2	3.1	98
		10		10.3	10.2	7.2	4.8	2.8	96
		15			8.8	6.7	4.4	2.5	94
		20			7.3	6.2	4.0	2.1	92
		25			5.7	5.6	3.6	1.7	90
1	SW4 96151004	5		21.3	20.5	13.5	6.6		81
		10		18.7	18.3	11.8	5.2		78
		15		16.0	15.9	10.1	3.8		76
		20		13.3	13.3	8.6	2.0		73
		25		10.5	10.5				71
	SW5 96151005	5			18.3	15.2	9.5	4.4	89
		10			16.1	13.8	8.5	3.4	87
		15			13.9	12.4	7.4	2.3	85
		20			11.4	10.9	6.0	1.1	82
		25			8.8	8.8	4.7		80
	SW6 96151006	5			11.4	11.3	9.3	6.7	118
		10				10.1	8.6	6.2	116
		15				8.7	8.0	5.7	113
		20				7.2	7.1	5.3	111
		25					5.7	4.8	108

- Notes:**
1. Pressure switch preset to 30-50 psi.
 2. Injector kits are purchased separately.
 3. Maximum pump working pressure is 150 psi.

Non-Submersible Pumps

Convertible VersaJet Pro Series Jet Pumps

Deep Well Performance

CVJ Pro Series			Discharge Pressure - PSI						Shut-off Pressure PSI
HP	Injector Kit	Suction Lift Ft	30	35	40	45	50	55	
			Gallons per Minute						
1/2	DW2 96152002	30	11.1	7.2	4.0	1.3			65
		40	9.3	5.7	2.7				60
		50	7.4	4.2	1.5				55
		60	5.6	2.7					51
		70	4.1	1.3					45
		80	2.7						40
		90	1.2						35
	DW1 96152001	30		6.6	5.0	3.4	2.2	1.3	97
		40	6.6	6.0	4.2	2.8	1.7	0.9	92
		50	6.6	5.1	3.5	2.3	1.3		86
		60	5.9	4.1	2.7	1.7	0.8		81
		70	5.0	3.4	2.2	1.2			76
		80	4.1	2.7	1.6	0.8			70
		90	3.1	2.0	1.1				65
3/4	DW2 96152002	30	12.2	9.9	6.3	3.5	0.8		74
		40	11.4	8.2	4.9	2.2			69
		50	9.7	6.5	3.5	0.8			64
		60	7.9	4.8	2.1				59
		70	6.1	3.4	0.8				53
		80	4.3	2.0					48
		90	2.5	0.6					43
	DW4 96152004	30		7.9	5.9	4.1	2.7	1.4	94
		40	7.9	6.9	5.0	3.4	2.1	0.9	88
		50	7.5	5.8	4.1	2.6	1.4		83
		60	6.6	4.7	3.2	1.9	0.8		77
		70	5.5	3.9	2.5	1.3			71
		80	4.4	3.1	1.7	0.6			66
		90	3.3	2.3	1.0				60
1	DW3 96152003	30		16.5	9.8	3.5			67
		40		13.0	6.9	1.0			62
		50		9.4	4.1				57
		60		5.9	1.2				52
	DW2 96152002	30		12.2	10.3	7.0	4.1	1.5	87
		40		11.4	8.6	5.5	2.8		82
		50		9.7	6.9	4.0	1.4		76
		60		8.2	5.2	2.5			71
		70		6.6	3.8	1.3			66
		80		4.9	2.5				60
	DW4 96152004	30		7.9	7.8	6.3	4.8	3.3	111
		40		7.9	7.3	5.4	4.0	2.6	105
		50		7.8	6.3	4.6	3.2	2.0	99
		60		7.0	5.2	3.7	2.4	1.3	93
		70		6.0	4.4	3.0	1.8	0.7	87
		80		5.1	3.6	2.3	1.2		82
		90		4.1	2.8	1.6	0.6		76

- Notes: 1. Pressure switch preset to 30-50 psi.
 2. Injector kits are purchased separately.
 3. Maximum pump working pressure is 150 psi.

Non-Submersible Pumps

Convertible VersaJet Pro Series Jet Pumps

Suction Flange Kits (Modular Face Plates):

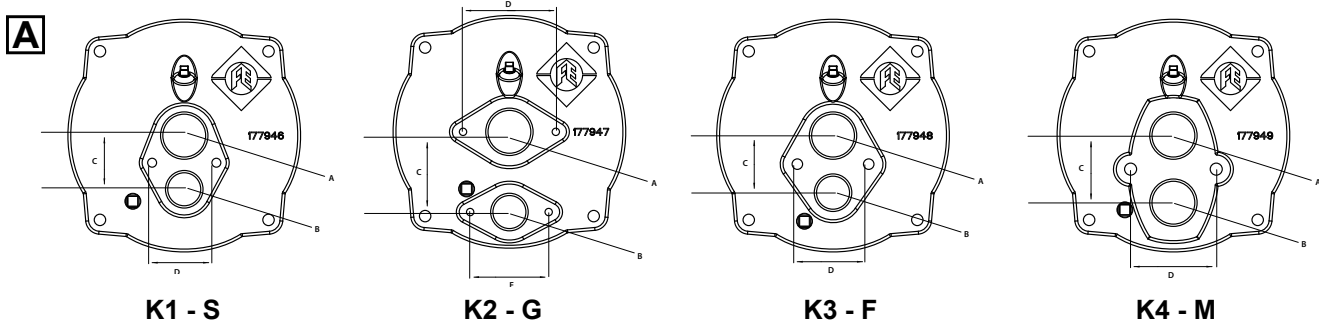

Contact Franklin Electric customer service for competitive replacement identification.

Model No.	Order No.	Wt.
K1 - S	96150946	7.8
K2 - G	96150947	8.1
K3 - F	96150948	8.0
K4 - M	96150949	8.4

Model No.	A	B	C	D	E
K1-S	1.25"	1.25"	2.35"	3.0"	-
K2-G	1.25"	1"	2.81"	3.25"	2.75"
K3-F	1.25"	1"	2.0"	2.5"	-
K4-M	1.25"	1.25"	2.35"	3.0"	-

Flange kits are designed for use in deep set retrofit applications where pump is being replaced but injector assembly is staying in the well.

Shallow Well Injector Kits:

Model No.	Order No.	Wt.
SW1	96151001	11.7
SW2	96151002	11.7
SW3	96151003	11.7
SW4	96151004	11.7
SW5	96151005	11.7
SW6	96151006	11.7
SW7	96151007	11.7

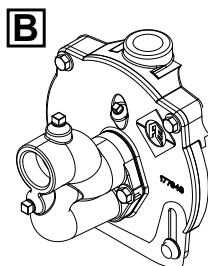

Shallow well kit includes shallow well injector assembly, K1-S suction flange and hardware.

Deep Well Injector Kits:

Model No.	Order No.	Wt.
DW1	96152001	12.6
DW2	96152002	12.6
DW3	96152003	12.6
DW4	96152004	12.6
DW5	96152005	12.6

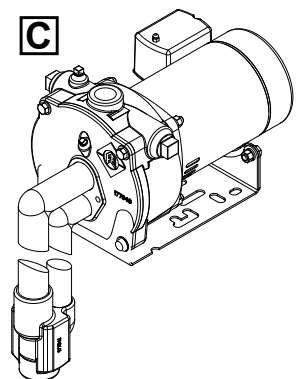

Deep well kit includes deep well injector assembly, K1-S suction flange and hardware.

Control valve required for deep well installations.

Control Valve:

Model No.	Order No.	Wt.
DW-CV	96150951	1.9

Non-Submersible Pumps

Convertible VersaJet Series Jet Pumps - Features

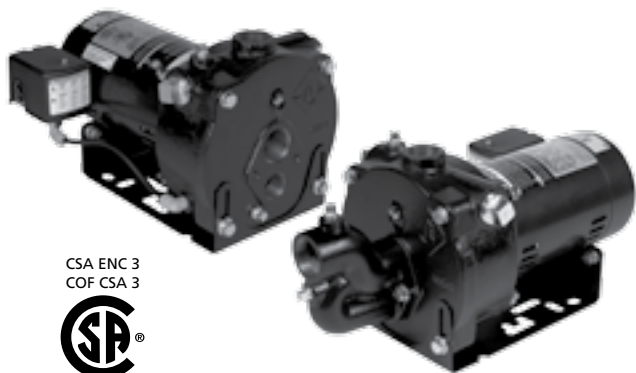

CSA ENC 3
COF CSA 3



Although no single pump can meet all applications, the Convertible VersaJet from Franklin Electric comes close. Each model can be configured with a variety of pressure and flow choices in both shallow and deep set installations. In addition, four different suction flange options make this pump the contractor's choice for those tough replacement jobs.

Features:

- Heavy-duty cast iron case ensures optimum durability and long life.
- Modular suction flange system to retrofit current installations without disturbing the existing plumbing.
- Thermoplastic impeller and diffuser precision molded for high efficiency and dependability.
- Thermoplastic impeller and diffuser ensure increased hydraulic performance.
- Phenolic/Ceramic mechanical shaft seal ensures leakproof fit and maximum pressure handling capability.
- Adjustable pressure switch is factory set at 30/50 psi.
- Powered by high quality, industry proven, UL778 approved indoor/outdoor square flange motors.
- Dual voltage motor can be set to run at either 115 V or 230 V.
- Built in drain plug for easy winterization and servicing.
- Pressure switch is installed and set at 30/50 psi.
- Connections:
1-1/4" FNPT Suction
1" FNPT Discharge
1" FNPT Drive Line

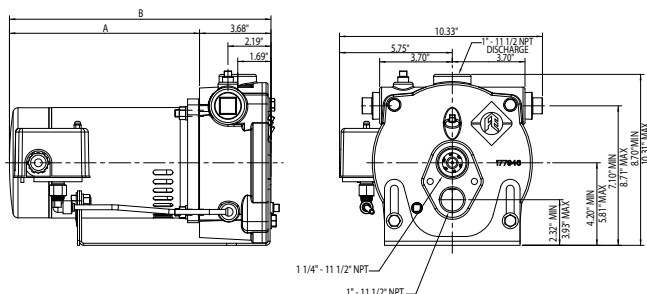

Dimensional illustration shown with K1-S flange installed.

Dimensions:

HP	A	B
1/2	9.63	13.31
3/4	10.38	14.06
1	11.00	13.68
1.5	11.88	15.56

Ordering Information:

Model No.	HP	Discharge x Suction	Voltage	Pump (without flange kit)		Pump, Injector, and Flange			
				Order No.	Wt.	Shallow Well Kits		Deep Well Kits	
						Order No.	Wt.	Order No.	Wt.
FCVJ05CI	1/2	1" x 1-1/4"	115/230	96130005	36.1	96130005SW	48	96130005DW	49
FCVJ07CI	3/4	1" x 1-1/4"	115/230	96130007	39.3	96130007SW	51	96130007DW	52
FCVJ10CI	1	1" x 1-1/4"	115/230	96130010	41.6	96130010SW	54	96130010DW	55
FCVJ15CI	1.5	1" x 1-1/4"	115/230	96130015	46.0	96130015SW	58	96130015DW	59

- Notes:**
1. Order suction flange kit A, or shallow well kit B, or deep well kit C depending upon application.
 2. Minimum inside well diameter requirement of 4" for deep well injectors.
 3. Control valve required for deep well installations.

Non-Submersible Pumps

Convertible VersaJet Series Jet Pumps

Shallow Well Performance

CVJ Series			Discharge Pressure - PSI						Shut-off Pressure PSI
HP	Injector Kit	Suction Lift Ft	30	40	50	60	70	80	
			Gallons per Minute						
1/2	SW1 96151001	5	11.5	7.0	3.9				61
		10	10.2	6.4	3.2				59
		15	9.1	5.8	2.4				57
		20	8.0	5.1	1.7				55
		25	6.5	4.4	0.8				53
	SW2 96151002	5	10.6	6.6	4.6	2.4			71
		10	9.3	6.2	4.1	1.9			69
		15	8.2	5.7	3.7	1.4			67
		20	6.8	5.2	3.1	1.0			65
		25	5.2	4.8	2.6	0.6			63
	SW3 96151003	5	8.0	5.8	4.6	3.2	1.9	0.8	88
		10	6.9	5.5	4.3	2.9	1.7	0.6	86
		15	5.9	5.2	4.0	2.7	1.4		84
		20		4.7	3.6	2.4	1.2		82
		25		3.7	3.3	2.1	1.0		80
3/4	SW5 96151005	5							
		10							
		15	16.7	14.0	8.2	2.8			65
		20		12.7	6.8	1.6			63
		25		11.3	5.7				61
	SW6 96151006	5	11.8	11.8	8.6	5.3	2.9	0.8	85
		10		10.2	7.8	4.7	2.5		83
		15		8.7	7.0	4.2	2.2		81
		20		7.1	6.2	3.8	1.7		79
		25			5.5	3.4	1.2		77
	SW7 96151007	5		8.2	7.9	5.7	3.8	2.4	101
		10		7.1	6.9	5.3	3.6	2.2	99
		15			6.1	4.8	3.3	1.9	97
		20			5.1	4.4	3.1	1.7	95
		25			4.1	4.0	2.7	1.4	93
1	SW4 96151004	5	21.4	18.6	11.8	5.2			68
		10	18.8	17.1	10.4	3.8			66
		15	16.2	15.4	8.9	2.4			64
		20	13.4	13.4	7.5	0.8			61
		25	10.5	10.5	6.2				59
	SW5 96151005	5	18.7	18.5	13.0	7.7	2.8		76
		10		16.4	11.8	6.6	1.6		73
		15		14.2	10.7	5.4			71
		20		11.6	9.5	4.5			69
		25		9.0	8.4	3.6			67
	SW6 96151006	5		11.7	11.1	7.8	5.2	3.1	98
		10		10.3	10.2	7.2	4.8	2.8	96
		15			8.8	6.7	4.4	2.5	94
		20			7.3	6.2	4.0	2.1	92
		25			5.7	5.6	3.6	1.7	90
1.5	SW4 96151004	5		21.3	20.5	13.5	6.6		81
		10		18.7	18.3	11.8	5.2		78
		15		16.0	15.9	10.1	3.8		76
		20		13.3	13.3	8.6	2.0		73
		25		10.5	10.5				71
	SW5 96151005	5			18.3	15.2	9.5	4.4	89
		10			16.1	13.8	8.5	3.4	87
		15			13.9	12.4	7.4	2.3	85
		20			11.4	10.9	6.0	1.1	82
		25			8.8	8.8	4.7		80
	SW6 96151006	5			11.4	11.3	9.3	6.7	118
		10				10.1	8.6	6.2	116
		15				8.7	8.0	5.7	113
		20				7.2	7.1	5.3	111
		25				5.7	5.7	4.8	108

- Notes:**
1. Pressure switch preset to 30-50 psi.
 2. Injector kits are purchased separately.
 3. Maximum pump working pressure is 150 psi.

Non-Submersible Pumps

Convertible VersaJet Series Jet Pumps

Deep Well Performance

HP	CVJ Series		Discharge Pressure - PSI						Shut-off Pressure PSI		
	Injector Kit	Suction Lift Ft	30	35	40	45	50	55			
			Gallons per Minute								
1/2	DW2 96152002	30	8.0	4.4	1.5				56		
		40	6.3	3.0					51		
		50	4.6	1.6					46		
		60	2.9						41		
		70	1.6						36		
	DW5 96152005	30	6.0	4.5	3.0	2.0	1.2		87		
		40	5.3	3.8	2.5	1.6	0.8		81		
		50	4.4	3.1	2.0	1.1			76		
		60	3.6	2.4	1.5	0.7			70		
		70	3.0	1.9	1.0				64		
		80	2.3	1.3	0.6				58		
		90	1.7	0.8					51		
		3/4	DW2 96152002	30	11.1	7.2	4.0	1.3			65
				40	9.3	5.7	2.7				60
50	7.4			4.2	1.5				55		
60	5.6			2.7					51		
70	4.1			1.3					45		
80	2.7								40		
DW1 96152001	90		1.2						35		
	30			6.6	5.0	3.4	2.2	1.3	97		
	40		6.6	6.0	4.2	2.8	1.7	0.9	92		
	50		6.6	5.1	3.5	2.3	1.3		86		
	60		5.9	4.1	2.7	1.7	0.8		81		
	70		5.0	3.4	2.2	1.2			76		
	80		4.1	2.7	1.6	0.8			70		
	90		3.1	2.0	1.1				65		
1	DW2 96152002	30	12.2	9.9	6.3	3.5	0.8		74		
		40	11.4	8.2	4.9	2.2			69		
		50	9.7	6.5	3.5	0.8			64		
		60	7.9	4.8	2.1				59		
		70	6.1	3.4	0.8				53		
		80	4.3	2.0					48		
	DW4 96152004	90	2.5	0.6					43		
		30		7.9	5.9	4.1	2.7	1.4	94		
		40	7.9	6.9	5.0	3.4	2.1	0.9	88		
		50	7.5	5.8	4.1	2.6	1.4		83		
		60	6.6	4.7	3.2	1.9	0.8		77		
		70	5.5	3.9	2.5	1.3			71		
		80	4.4	3.1	1.7	0.6			66		
		90	3.3	2.3	1.0				60		
1.5	DW3 96152003	30		16.5	9.8	3.5			67		
		40		13.0	6.9	1.0			62		
		50		9.4	4.1				57		
		60		5.9	1.2				52		
	DW2 96152002	30		12.2	10.3	7.0	4.1	1.5	87		
		40		11.4	8.6	5.5	2.8		82		
		50		9.7	6.9	4.0	1.4		76		
		60		8.2	5.2	2.5			71		
		70		6.6	3.8	1.3			66		
		80		4.9	2.5				60		
	DW4 96152004	90		3.3	1.1				55		
		30		7.9	7.8	6.3	4.8	3.3	111		
		40		7.9	7.3	5.4	4.0	2.6	105		
		50		7.8	6.3	4.6	3.2	2.0	99		
		60		7.0	5.2	3.7	2.4	1.3	93		
		70		6.0	4.4	3.0	1.8	0.7	87		
		80		5.1	3.6	2.3	1.2		82		
		90		4.1	2.8	1.6	0.6		76		

- Notes: 1. Pressure switch preset to 30-50 psi.
 2. Injector kits are purchased separately.
 3. Maximum pump working pressure is 150 psi.

Non-Submersible Pumps

Convertible VersaJet Series Jet Pumps

Suction Flange Kits (Modular Face Plates):

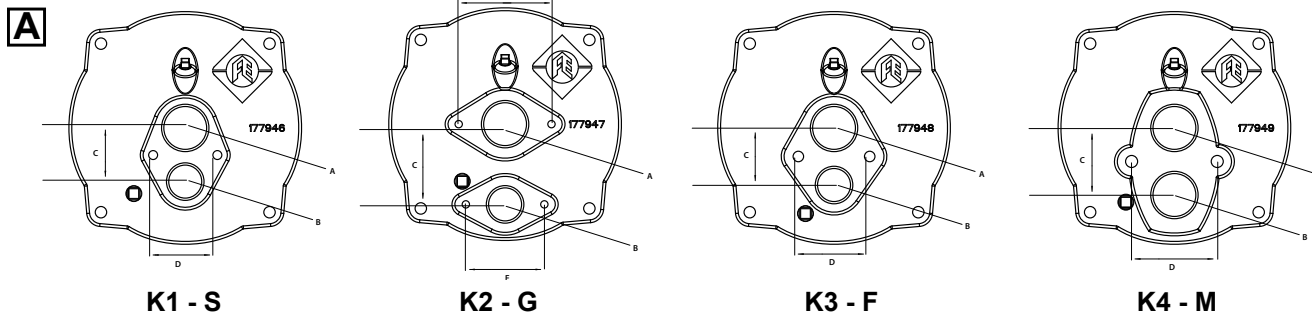

Contact Franklin Electric customer service for competitive replacement identification.

Model No.	Order No.	Wt.
K1 - S	96150946	7.8
K2 - G	96150947	8.1
K3 - F	96150948	8.0
K4 - M	96150949	8.4

Model No.	A	B	C	D	E
K1-S	1.25"	1.25"	2.35"	3.0"	-
K2-G	1.25"	1"	2.81"	3.25"	2.75"
K3-F	1.25"	1"	2.0"	2.5"	-
K4-M	1.25"	1.25"	2.35"	3.0"	-

Flange kits are designed for use in deep set retrofit application where pump is being replaced but injector assembly is staying in the well.

Shallow Well Injector Kits:

Model No.	Order No.	Wt.
SW1	96151001	11.7
SW2	96151002	11.7
SW3	96151003	11.7
SW4	96151004	11.7
SW5	96151005	11.7
SW6	96151006	11.7
SW7	96151007	11.7

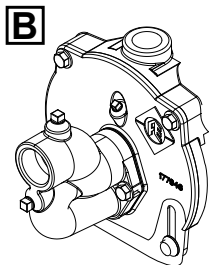

Shallow well kit includes shallow well injector assembly, K1-S suction flange and hardware.

Deep Well Injector Kits:

Model No.	Order No.	Wt.
DW1	96152001	12.6
DW2	96152002	12.6
DW3	96152003	12.6
DW4	96152004	12.6
DW5	96152005	12.6

Deep well kit includes deep well injector assembly, K1-S suction flange and hardware.

Control valve required for deep well installations.

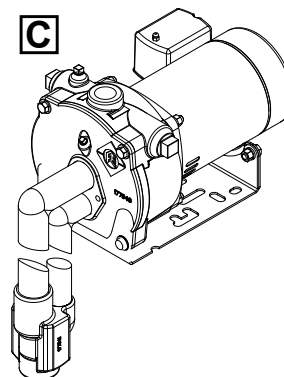

Control Valve:

Model No.	Order No.	Wt.
DW-CV	96150951	1.9

Non-Submersible Pumps

Pro Series Convertible Jet Pumps - Features



CSA ENC 3
COF CSA 3
C  US
CSA 108
UL 778

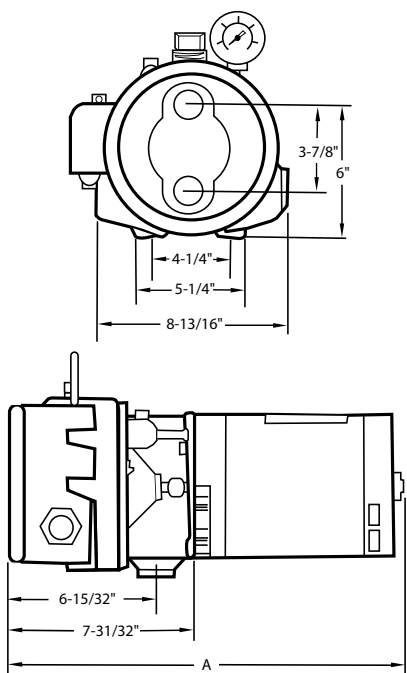

Pro Series

Features:

- Heavy-duty cast iron case and stainless steel impeller ensure optimum durability.
- Thermoplastic diffuser is molded for efficiency and dependability.
- Screw-in injector for easy conversion from shallow to deep well installation.
- Shaft coupling designed for easy removal of pump motor.
- Mechanical shaft seal ensures leakproof fit and continuous water lubrication.
- High service factor 56C-frame motor for maximum performance.
- Hardware kit allows for versatility of installation and includes pressure gauge, plugs, shallow well injector, and bypass plug.
- Adjustable pressure switch is factory-installed at 30/50 psi.
- Connections:
1-1/4" NPT suction
1" NPT discharge
1" NPT drive line
- Maximum temperature of 140 °F/60 °C

Dimensions		
Model	HP	A
FP05CI-C	1/2	18.65"
FP07CI-C	3/4	19.15"
FP1CI-C	1	19.65"

Note: Dimensions will vary according to motor manufacturer.

Non-Submersible Pumps

Pro Series Convertible Jet Pumps - Ordering Information

(See pgs. 2-3 for model number explanation)

Pro Convertible Jet Pumps								
Model	HP	Discharge x Suction	Voltage	Pump Unit		Deep Well Injector		
				Order No.	Wt.	Suction Lift	Order No.	Wt.
FP05CI-C	1/2	1" x 1-1/4"	115/230	91140005	48	30 - 60 ft	147E1120	7
						50 - 100 ft	147E0915	7
FP07CI-C	3/4	1" x 1-1/4"	115/230	91140007	51	30 - 60 ft	147E1023	7
						50 - 100 ft	147E1118	7
FP1CI-C	1	1" x 1-1/4"	115/230	91140010	53	30 - 60 ft	147E1125	7
						50 - 100 ft	147E1120	7

- Notes:**
1. Order deep well injector separately.
 2. Minimum inside well diameter requirement of 4" for deep well injectors.
 3. Weight in pounds.

Optional Injector for High Head Performance		
Injector Ordering No.	Model	HP
18-1278-03-R	FP1CI-C	1

Pressure Gauge	
Ordering No.	Pressure Reading
9193-4018	0-100 PSI

Required for Deep Well Installations:



Parallel Pipe Injectors

Non-Submersible Pumps

Pro Series Convertible Jet Pumps

Shallow Well Performance

Pro 1" Discharge x 1-1/4" Suction			Discharge Pressure - PSI									Shut-off Pressure PSI
Series	Injector Order No.	Total Suction Lift Ft	30	35	40	45	50	55	60	65	70	
			Gallons per Minute									
FP05 1/2 hp	18-1278-03-R	5	15.5	13.5	11	8.5	6	4	2			65
		10	13.5	12.5	10	7.5	5	3	1			63
		15	11.5	10.5	8.5	6	4	2				60
		20	9.5	9	7.5	5	3	1				58
		25	7	7	6	4	2					55
FP07 3/4 hp	18-1279-02-R	5	19	18.5	18	16	12.5	9.5	6.5	3.5		70
		10	16.5	16	15.5	14	10	8	4.5	1.5		68
		15	14.5	14	13.5	12.5	9.5	6.5	3.5			66
		20		11.5	11	10	8	5	2			63
		25			8.5	8	6.5	3.5	1			61
FP1 1 hp	18-1280-09-R	5	23	22.5	22	21.5	20	17.5	14	10.5	7	81
		10		19.5	19	18.5	17.5	15.5	12.5	9	5.5	78
		15		16.5	16	15.5	15	13.5	11	7.5	4.5	76
		20			13.5	13	12.5	11.5	9.5	6	2.5	74
		25				10	10	9.5	7.5	4.5	1	71
Series	Injector Order No.	Total Suction Lift Ft	Discharge Pressure - PSI									Shut-off Pressure PSI
			50	55	60	65	70	75	80	85	90	
Gallons per Minute												
High Head FP1 1 hp	18-1278-03-R	5			11	10	7.5	5.5	3.5	1.5		90
		10			10	8.5	6.5	4.5	2.5			88
		15			9	7.5	5.5	3.5	1.5			84
		20			8	6	4	2				81
		25			7	5	3	1				78

- Notes:**
1. Pressure switch pre-set 30-50 psi.
 2. The appropriate injector is included with the units.
 3. Maximum pump working pressure is 150 psi.
 4. All the above discharge pressures were measured using 1.25" PVC suction pipe and 1.25" foot valve.

Non-Submersible Pumps

Pro Series Convertible Jet Pumps

Deep Well Performance

Pro 1" Discharge x 1-1/4" Suction 1" Drive Pipe			Discharge Pressure - PSI									Shut-off Pressure PSI	Inj. Min. Operating Pressure	
Series	Injector Order No.	Total Suction Lift Ft	30	35	40	45	50	55	60	65	70			
			Gallons per Minute											
FP05 1/2 hp	147E-1120	30	9	7	5.5	4	2.5	1.5				65	18	
		40	7.5	6	4	3	1.5					59		
		50	6	4.5	3	2	1					56		
		60	5	3.5	2	1						52		
	147E-0915	50	6	5	4	3	2.5	2	1				74	23
		60	5	4	3.5	2.5	2	1					70	
		70	4	3.5	2.5	2	1.5						65	
		80	3.5	3	2	1.5	1						61	
		90	3	2	1.5	1							57	
		100	2.5	1.5	1								52	
FP07 3/4 hp	147E-1023	30	15.5	13.5	11	8.5	6.5	4	2			66	18	
		40	13.5	11.5	9	7	4.5	2.4				61		
		50	11	9.5	7	5	3					57		
		60	9	7.5	5	3	1					53		
	147E-1118	50	9	8	7	6	4.5	3.5	3	2	1		80	23
		60	8	7	6	4.5	4	3	2	1.5			77	
		70	6.5	5.5	4.5	3.5	3	2	1				72	
		80	6	5	4	3	2	1.5					67	
		90	5	4	3	2	1.5						63	
		100	4	3	2.5	1.5	1						30	
FP1 1 hp	147E-1125	30	19.5	17	14.5	12	9.5	7	5			72	30	
		40	17.5	15	12.5	10	7.5	5	3			67		
		50	15.5	13	10.5	8	5.5	3.5	1			63		
		60	13	10.5	8.5	6	3.5	1.5				59		
	147E-1120	50		11	9.5	8	6.5	5	4	3	2		82	36
		60		10	8	7	5.5	4	3	2	1		78	
		70		8	7	6	4.5	3	2	1			73	
		80		7	6	4.5	3.5	2	1.5				70	
		90		6	5	3.5	2.5	1.5					65	
		100		5	4	3	1.5						61	

Notes: 1. Pressure switch pre-set 30-50 psi.

2. Maximum pump working pressure is 150 psi.

3. All the above discharge pressures were measured using 1.25 PVC suction pipe and 1.25 foot valve and 1 drive pipe.

Non-Submersible Pumps

Jet Pump Accessories - Ordering Information

Deep Well 2-Pipe Injectors for 4" Wells			
Pump Model	Suction Lift	Order No.	Wt.
FP05CI-C	50 - 100 ft	147E0915	7
FP07CI-C	30 - 60 ft	147E1023	
FP07CI-C	50 - 100 ft	147E1118	
FP05CI-C	30 - 60 ft	147E1120	
FP1CI-C	50 - 100 ft	147E1120	
FP1CI-C	30 - 60 ft	147E1125	

Injector kit includes: Cast iron body, thermoplastic nozzle & venturi, bronze foot valve.

Accessory Description	Order No.	Wt.
4-in-1 Foot Valve, 3/4" - 1.5"	21339	1
Cast Iron Horizontal Check Valve, Poppet Type Bronze, 1-1/4" F x 1-1/4" M	305466002	4

Notes: 1. For touch-up paint, see your local Sherwin Williams paint store for part #1415066.
2. Weight in pounds.



Parallel Pipe Injector



4-in-1 Foot Valve



Horizontal Check Valve

Non-Submersible Pumps

Jet Pump Accessories - Ordering Information

Screw-In Shallow Well Injectors			
Pump Model	Injector Code	Order No.	Wt.
FP05CI-C, FP1CI-C	1024	18127803R	0.5
FP07CI-C	1027	18127902R	
FP1CI-C	1028	18128009R	

Pressure Switches			
Description	PSI Setting	Order No.	Wt.
Global Series	20/40	PRSW2040	1
	30/50	PRSW3050	1
	40/60	PRSW4060	1
Furnas Pro Series	20/40	69ES1AZ2040	1
	30/50	69ES1AZ3050	1
	40/60	69ES1AZ4060	1

Pressure Gauge, 0 - 100 psi, 1/4" b.m.	9193-4018	1
--	-----------	---

External Control Valve	9198-2538	2
------------------------	-----------	---

Note: Weight in pounds.



Shallow Well Injector



Furnas Pressure Switch



Global Pressure Switch



Pressure Gauge

Non-Submersible Pumps

Jet Pump Accessories - Ordering Information

(See pgs. 2-3 for model number explanation)

AQ80

Features:

- Constant pressure at flow rates of 1/2 gpm or higher, eliminating the annoying pressure fluctuations common with pump/tank systems.
- Pump runs continuously while service is needed, eliminating short cycling, the major cause of motor wear and failure.
- Handles flow rates up to 20 gpm. For flow rates above 20 gpm, AQ80 may be connected in parallel to handle each 20 gpm increment.
- Retrofit to any existing pump and pressure tank system.

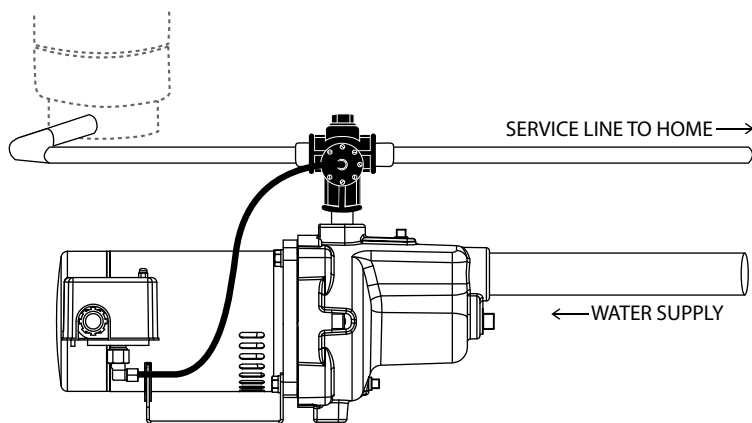

Components of Jet Pump Installation

Left is an example of a shallow well application for your jet pump with the constant pressure valve. Your installation may be slightly different but the application is basically the same. Consult your dealer for assistance with your particular application.

AQ80

Works at any flow rate **above 1/2 gpm**. Provides **constant pressure** at each specific flow rate delivered by the pump. (Pressure will be slightly different for each flow rate.) A pressure tank is recommended for optimum performance.

Maximum operating pressure: 80 psi. (If installed with a submersible pump that develops more than 80 psi at the inlet of the AQ80, use a pressure regulator to protect the AQ80 from excessive pressure.)

Model	Preset Outlet Pressure	Inlet	Outlet	Tank Connection	Max. Inlet Pressure	Order No.	Wt.
AQ80	None	1"	1"	1"	80 psi	91987321	2

Note: Weight in pounds.

Jet Pump Accessories - Ordering Information

Air Charger Kit



Features:

- Specifically designed to prevent water-logging typically associated with a conventional galvanized pressure tank.
- Automatically maintains a proper balance of air and water volume in the tank.
- Eliminates frequent starts and stops, thus extending motor life and reducing power consumption.
- Eliminates tank draining normally required with water-logged tanks.
- Eliminates need for other costly equipment.
- Unit consists of air charger, reducer bushing, adapter nut, 1/4" polyethylene tubing, and male connector.

Model	Ordering No.	Wt.
Air Charger	106594901	2

Note: Weight in pounds.

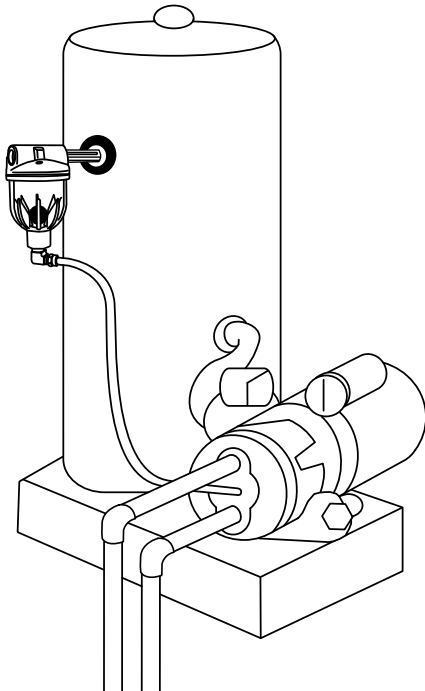

Non-Submersible Pumps

Turf Boss Self-Priming Centrifugal Pumps - Features



CSA ENC 3
COF CSA 3



TURFBOSS

Features:

- Self-priming design, with the ability to lift water from a depth of 25'.
- Easily serviced through a back pull-out design, which leaves the plumbing and both the pump's base and case undisturbed in their original location.
- Rugged pump case constructed with heavy-duty cast iron ensures optimum durability, quiet operation and long life.
- Hydraulic components molded with Noryl®* thermoplastic, when coupled with the floating stainless steel impeller eye-seal, ensures dependable and efficient operation.
- Available with a 304 stainless steel impeller for maximum durability.
- Industry proven indoor and outdoor 56J motors.
- Single-phase: 1 and 1.5 hp motors are dual voltage, set to run with either 115 or 230 V incoming power (2 hp is 230 V only).
- Available in all horsepower with a three-phase motor.
- Mechanical shaft seal allows positive protection against leaking.
- Built-in drain plug for easy winterizing and servicing.
- Shut-off pressures up to 130 feet, and flow rates to 70 gpm.
- Handles water temperatures up to 120 °F.
- Integrated 1" NPT priming plug.
- 1.5" FNPT suction, 1.5" FNPT discharge.

Noryl® is a registered trademark of G.E.

1.5" NPT Suction 1.5" NPT Discharge

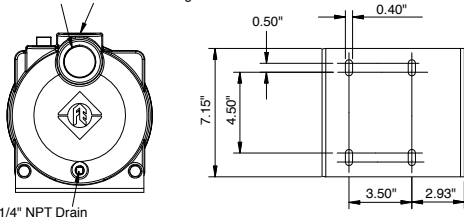

1/4" NPT Drain

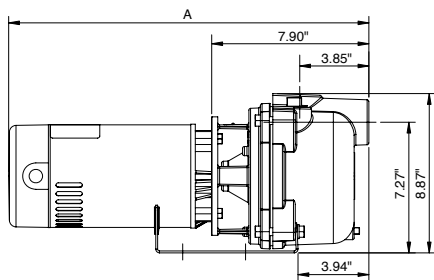

Dimensions		
HP	Single-Phase	Three-Phase
	A	A
1	20.0"	23.4"
1.5	21.6"	25.0"
2	21.6"	25.0"

Note: Dimensions will vary according to motor manufacturer.

Non-Submersible Pumps

Turf Boss Pumps - Ordering Information

(See pgs. 2-3 for model number explanation)

Single-Phase

HP	Discharge x Suction	Voltage	Noryl Impeller			Stainless Steel Impeller		
			Model	Order No.	Wt.	Model	Order No.	Wt.
1	1.5" x 1.5"	115/230	FTB1CI	92980010	50	FTB1CI-SSI	92981010	52
1.5	1.5" x 1.5"	115/230	FTB15CI	92980015	57	FTB15CI-SSI	92981015	59
2	1.5" x 1.5"	230	FTB2CI	92980020	58	FTB2CI-SSI	92981020	60

Three-Phase

HP	Discharge x Suction	Voltage	Stainless Steel Impeller		
			Model	Order No.	Wt.
1	1.5" x 1.5"	208-230/460	FTB1CI-SSI-T	92983010	51
1.5	1.5" x 1.5"	208-230/460	FTB15CI-SSI-T	92983015	55
2	1.5" x 1.5"	208-230/460	FTB2CI-SSI-T	92983020	57

Pump End Only

HP	Discharge x Suction	Noryl Impeller			Stainless Steel Impeller		
		Model	Order No.	Wt.	Model	Order No.	Wt.
1	1.5" x 1.5"	TB1CI-PE	92940010	28	TB1CI-SSI-PE	92941010	30
1.5	1.5" x 1.5"	TB15CI-PE	92940015	28	TB15CI-SSI-PE	92941015	30
2	1.5" x 1.5"	TB2CI-PE	92940020	28	TB2CI-SSI-PE	92941020	30

Note: Weight in pounds.

Non-Submersible Pumps

Turf Boss Self-Priming Centrifugal Pumps

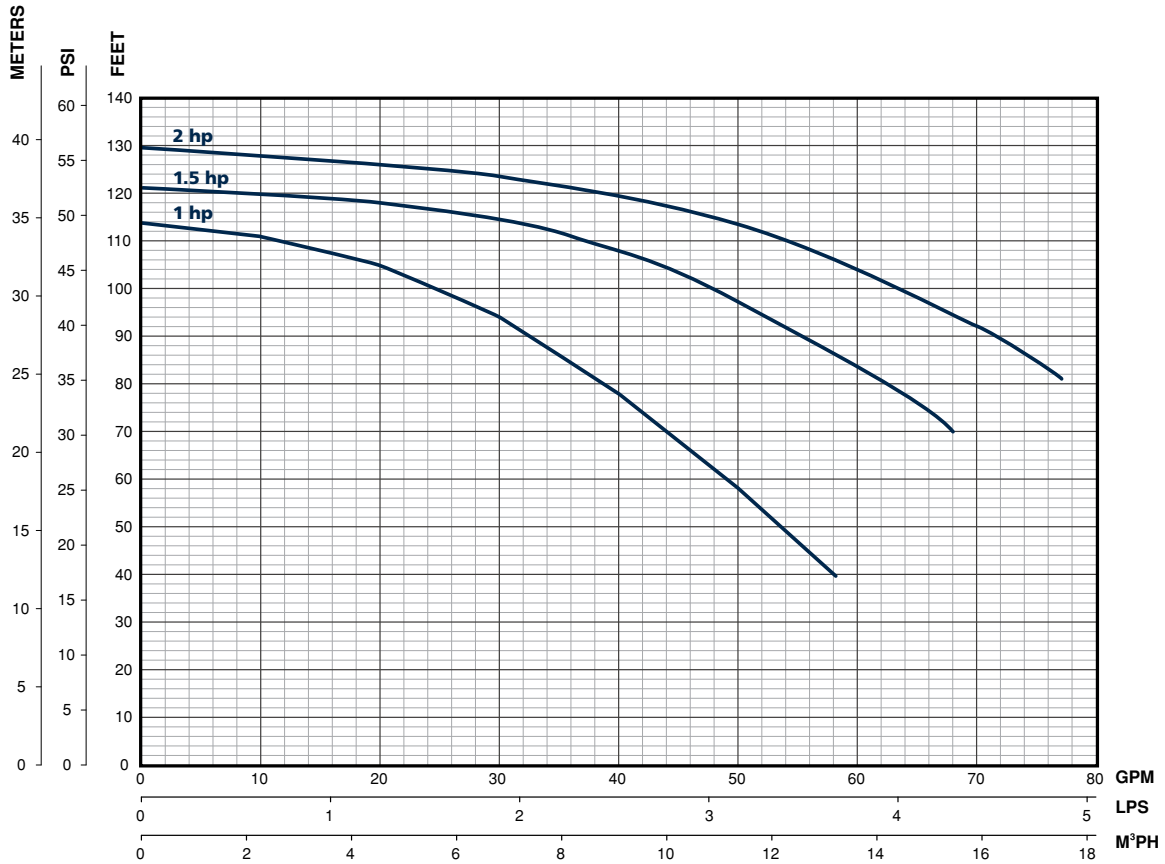

Model	Suction Lift Ft	Discharge Pressure - PSI							Shut-off Pressure PSI
		20	25	30	35	40	45	50	
FTB1CI	5	53	47	42	36	27	13	-	46
	10	49	45	38	32	23	-	-	44
	15	45	43	37	28	17	-	-	42
	20	38	37	33	24	-	-	-	40
	25	28	27	27	18	-	-	-	38
FTB15CI	5	65	64	63	58	48	37	-	50
	10	58	58	57	55	45	26	-	48
	15	50	49	48	48	40	-	-	46
	20	41	40	39	38	32	-	-	44
	25	29	28	28	27	17	-	-	42
FTB2CI	5	70	69	69	68	65	53	35	52
	10	61	60	60	59	58	47	-	50
	15	52	51	50	49	48	37	-	49
	20	41	40	39	38	35	-	-	47
	25	29	28	27	25	22	-	-	45

Non-Submersible Pumps

DDS Series End Suction Centrifugal Pumps - Features



CSA ENC 3
COF CSA 3



Features:

- Stainless steel construction on all models.
- Back pull-out design provides access to internal parts without disturbing the plumbing.
- Mechanical shaft seal ensures a leakproof fit and continuous water lubrication.
- Maximum temperature limit of 140 °F/60 °C and maximum working pressure of 150 psi.
- Square-flange open drip-proof motor for easy service and reliability.
- Available in single- and three-phase models.
- Enclosed impeller design for increased efficiencies.
- Viton® mechanical shaft seal for added chemical resistance.
- 304SS case and seal plate.

Viton® is a registered trademark of Dupont Dow Elastomers.

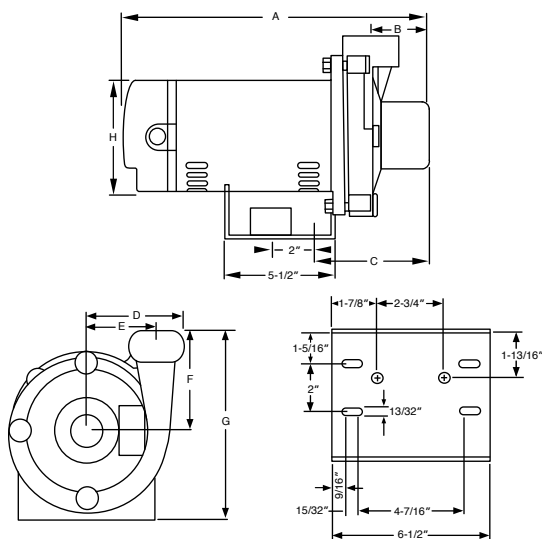

Dimensions

HP	Disch. (NPT)	Suct. (NPT)	A	B	C	D	E	F	G	H
1/2	1"	1-1/4"	14-11/16"	2-3/8"	5-5/16"	4-7/16"	3-1/2"	4-5/8"	8-3/4"	5-1/2"
3/4	1"	1-1/4"	14-11/16"	2-3/8"	5-5/16"	4-7/16"	3-1/2"	4-5/8"	8-3/4"	5-1/2"
1	1"	1-1/4"	14-11/16"	2-3/8"	5-5/16"	4-7/16"	3-1/2"	4-5/8"	8-3/4"	5-1/2"
1.5	1"	1-1/4"	15-3/16"	2-3/8"	5-5/16"	4-7/16"	3-1/2"	4-5/8"	8-3/4"	5-1/2"

Non-Submersible Pumps

DDS Series Pumps - Ordering Information

(See pgs. 2-3 for model number explanation)

Stainless Steel

DDS Series Centrifugal Pump Units							
HP	Discharge x Suction	Single-Phase			Three-Phase - 208-230/460 Volt		
		Model No.	Order No.	Wt.	Model No.	Order No.	Wt.
1/2	1" x 1-1/4"	5FPDDS1-S	93178056	25	5FPDDS1-T	93178098	25
3/4	1" x 1-1/4"	7FPDDS1-S	93178064	29	7FPDDS1-T	93178106	29
1	1" x 1-1/4"	1FPDDS1-S	93178072	31	1FPDDS1-T	93178114	31
1.5	1" x 1-1/4"	15FPDDS1-S	93178080	36	15FPDDS1-T	93178122	36

Pump End Kits

DDS Series Centrifugal Pump End Kits for 3500 R.P.M. - O.D.P. Motors							
Discharge x Suction	HP Range	Phase	Motor Frame Size	Max. Imp. Diameter	Pump End Kit		
					Model	Order No.	Wt.
1" x 1-1/4"	1/2 - 1.5	1 or 3	56Z	5.315"	FPDDS1-K1	93174137R378	12

Note: Weight in pounds.

Non-Submersible Pumps

DDS Series End Suction Centrifugal Pumps

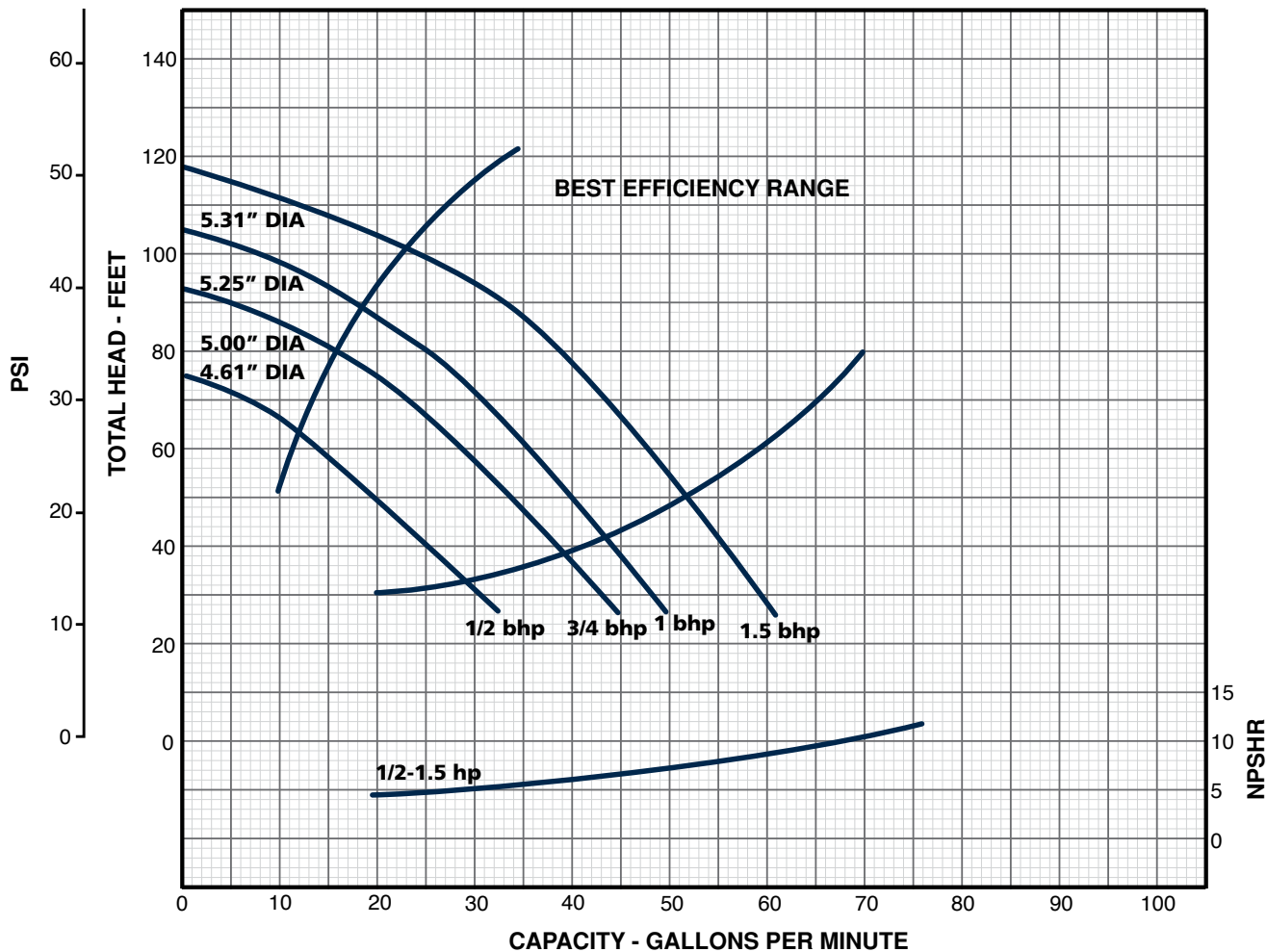

HP	Discharge x Suction	Capacities GPM											Shut-off Head (ft)	
		Total Head in Ft												
		30	35	40	45	50	60	70	80	90	100	110		
1/2	1" x 1-1/4"	30	27	25	22	19	14	-	-	-	-	-	-	74
3/4	1" x 1-1/4"	-	41	38	36	34	29	23	16	-	-	-	-	93
1	1" x 1-1/4"	-	-	-	42	40	36	31	25	18	-	-	-	105
1.5	1" x 1-1/4"	-	-	-	-	52	47	44	39	34	25	-	-	118

Note: All performance data based on rated nameplate voltage.

Non-Submersible Pumps

FCE Series Close-Coupled Centrifugal Pumps - Features

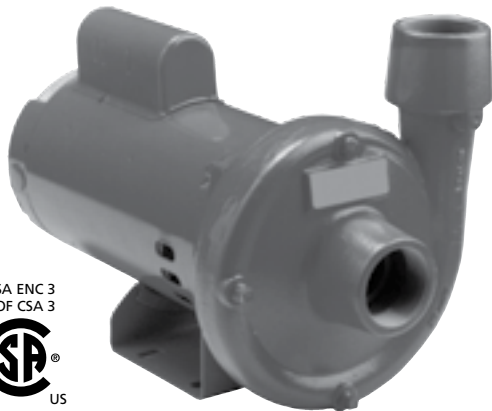

CSA ENC 3
COF CSA 3



FPS

FCE series

Features:

- Cast iron volute can be rotated for ease of installation.
- Impeller with a stainless steel hub is molded with Noryl®. Noryl® thermoplastic is a proven dependable material known for its properties to increase efficiency and hydraulic performance.
- Powered by high quality, industry proven, UL778 approved indoor/outdoor square flange motors.
- Single-phase: 1 and 1.5 hp motors are dual voltage, set to run with either 115 or 230 V incoming power (2 hp is 230 V only).
- All horsepower are available with three-phase motors.
- Built-in drain plug for easy winterizing and servicing.
- Can be mounted in a vertical or horizontal position.
- Shut-off pressures up to 125 feet.
- Flow capacities up to 85 gpm.
- Handles water temperatures up to 160 °F / 71 °C.
- UL778 approved for indoor or outdoor use.

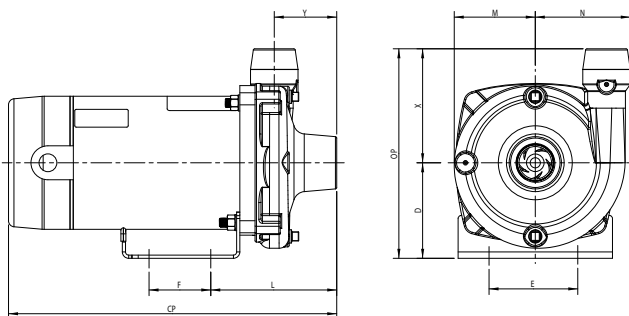

Dimensions:

HP	Disch. (NPT)	Suct. (NPT)	CP	D	E	F	L	M	N	OP	X	Y
1/2	1"	1-1/4"	13.75"	4.00"	4.88"	3.00"	5.53"	3.69"	4.00"	8.90"	4.90"	2.63"
3/4	1"	1-1/4"	14.07"	4.00"	4.88"	3.00"	5.53"	3.69"	4.00"	8.90"	4.90"	2.63"
1	1"	1-1/4"	15.57"	4.00"	4.88"	3.00"	5.53"	3.69"	4.00"	8.90"	4.90"	2.63"
1.5	1"	1-1/4"	15.90"	4.00"	4.88"	3.00"	5.53"	3.69"	4.00"	8.90"	4.90"	2.63"
2	1-1/4"	1-1/2"	15.82"	4.46"	4.88"	3.00"	5.88"	4.12"	4.72"	10.78"	6.31"	2.88"

Notes: Dimensions are for estimating purposes only. All dimensions in inches.

Ordering Information:

HP	Discharge x Suction	Single-Phase				Three-Phase			
		Voltage	Model No.	Order No.	Wt.	Voltage	Model No.	Order No.	Wt.
1/2	1" x 1-1/4"	115/230	FCE05CI	90200005	31	208-230/460	FCE05CI-T	90203005	29
3/4	1" x 1-1/4"	115/230	FCE07CI	90200007	32	208-230/460	FCE07CI-T	90203007	31
1	1" x 1-1/4"	115/230	FCE1CI	90200010	37	208-230/460	FCE1CI-T	90203010	34
1.5	1" x 1-1/4"	115/230	FCE15CI	90200015	42	208-230/460	FCE15CI-T	90203015	39
2	1-1/2" x 1-1/4"	230	FCE2CI	90200020	46	208-230/460	FCE2CI-T	90203020	42

Pump Kit Ordering Information:

HP	Model No.	Order No.	Discharge x Suction	Wt.
3/4	CE07CI-PE	90160007	1" x 1-1/4"	14
1.5	CE15CI-PE	90160015	1" x 1-1/4"	14
2	CE2CI-PE	90160020	1" x 1-1/4"	14

Notes: All dimensions in inches. All weight in pounds.

Non-Submersible Pumps

FCE Series Close-Coupled Centrifugal Pumps

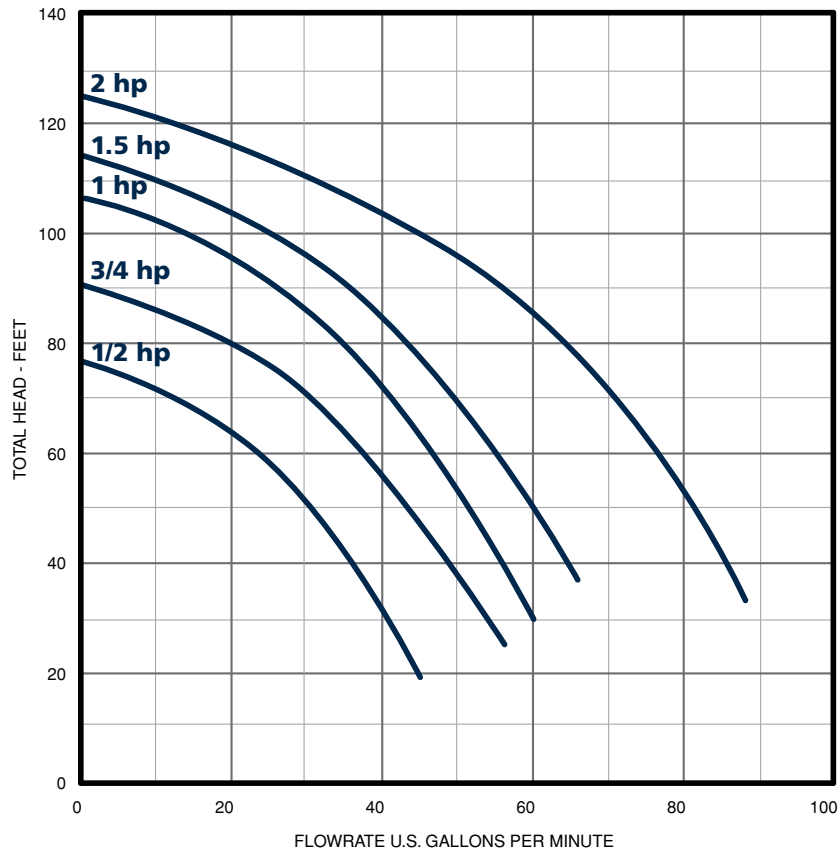

HP	Discharge x Suction	Capacities GPM											Shut-off Head (ft)
		Total Head in Ft											
		10	20	25	30	35	40	45	50	60	70	80	
1/2	1" x 1-1/4"	71	63	58	50	41	30	18	-	-	-	-	76
3/4	1" x 1-1/4"	85	78	74	69	62	54	46	36	-	-	-	90
1	1" x 1-1/4"	102	95	90	85	78	71	62	52	29	-	-	106
1.5	1" x 1-1/4"	109	103	99	95	90	83	76	68	50	-	-	113
2	1-1/2" x 1-1/4"	120	115	113	110	107	103	99	94	84	71	53	124

Note: All lengths are in inches.

Non-Submersible Pumps

A Series Non-Corrosive Centrifugal Pumps - Features



FPS

A series

Flooded suction centrifugal pump suitable for use with saltwater, chemical transfer, and other pumping applications that deal with corrosive substances.

Features:

- High tech, non-corrosive plastic construction. All metal components that have contact with liquid are stainless steel.
- Motor shaft is completely insulated from any contact with pumping liquid.
- 2" union connections ensure easy service and optimum water flow. Unions must be ordered separately.
- Discharge port easily rotates to 90 degree increments without removing motor.
- Lightweight design.

Ordering Information

A Series Thermoplastic Centrifugal Pumps					
Model	HP	Discharge x Suction	Voltage	Pump Unit	
				Order No.	Wt.
S2A	2	2" MNPT x 2"	115/230	94216151	27
S3A	3	2" MNPT x 2"	230	94216191	29
S35A	3.5	2" MNPT x 2"	230	94216201	31
S4A	4	2" MNPT x 2"	230	94216301	35
S45A	4.5	2" MNPT x 2"	230	94216401	39
Fittings kit contains (2) 2" slip x threaded connection union halves				31150109	2

Note: Set of union halves must be purchased separately. Weight in pounds.

Non-Submersible Pumps

A Series Non-Corrosive Centrifugal Pumps

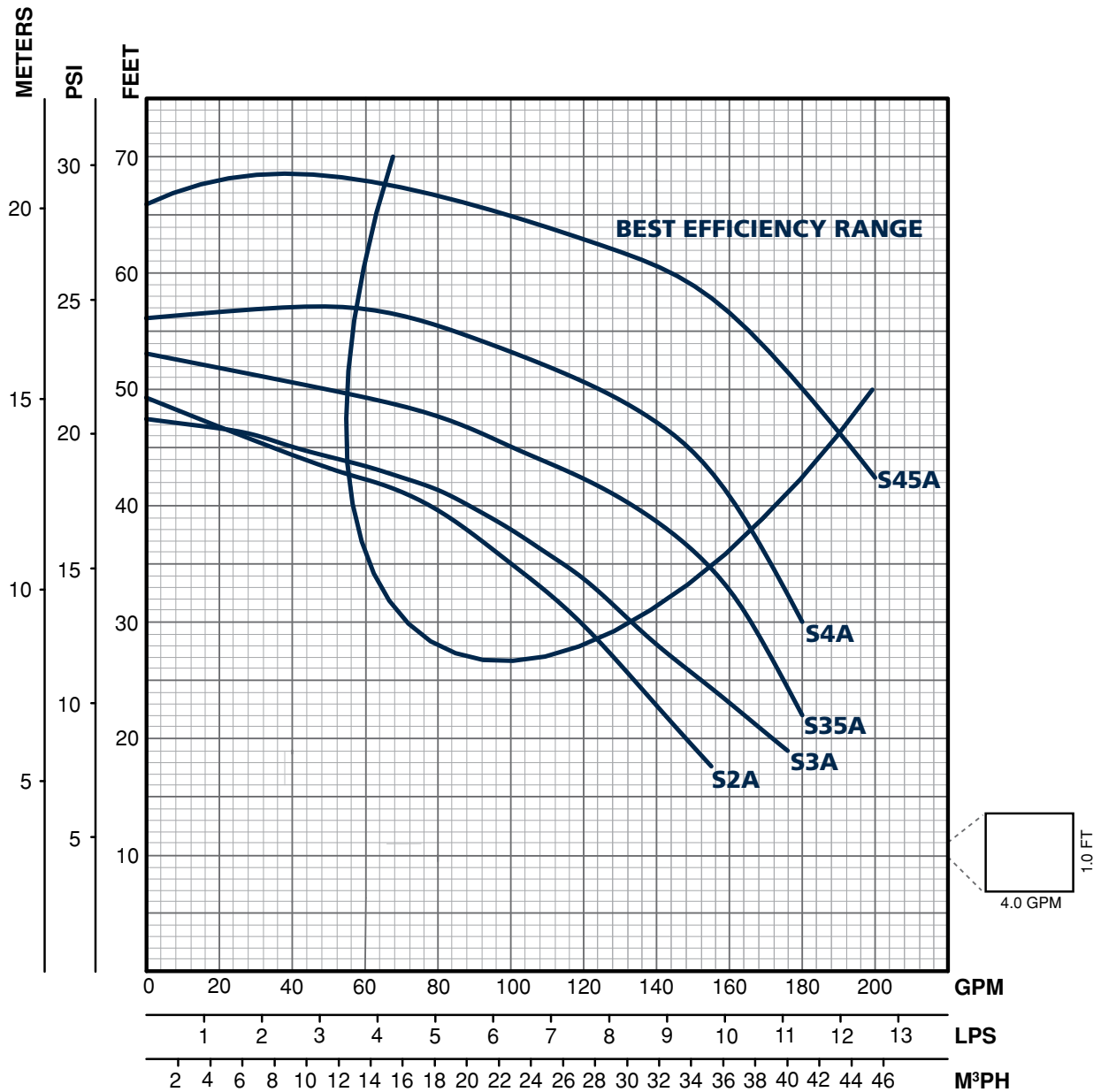

Non-Submersible Pumps

S Series Non-Corrosive Centrifugal Pumps - Features

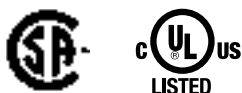

This flooded suction centrifugal pump is suitable for use with saltwater, chemical transfer (please consult factory for specific chemical compatibility and other pumping applications that deal with corrosive substances).

Features:

- High tech, non-corrosive plastic construction. All metal components that have contact with liquid are stainless steel.
- Motor shaft is completely insulated from any contact with pumping liquid.
- Mechanical seal has ceramic and carbon faces. All other parts are buna-n-rubber and stainless steel.
- Patented air cooled heat sink allows pump to run dry or in loss-of-prime conditions without damage to the shaft seal. Unconditional two year warranty against seal failure.
- Floating eye seal on the impeller maximizes pump efficiency for best flow and pressure.
- Will accept either a standard 1.5" union or a male 1.5" pipe thread. Unions must be ordered separately.
- UL and CSA agency listing do not apply to any application other than water applications.

Ordering Information

S Series Thermoplastic Centrifugal Pumps					
Model	HP	Discharge x Suction	Voltage	Pump Unit	
				Order No.	Wt.
S7KM	3/4	1-1/2" MNPT x 1-1/2"	115	94028263	22
S1KM	1	1-1/2" MNPT x 1-1/2"	115	94028271	24
S15KM	1.5	1-1/2" MNPT x 1-1/2"	115	94028289	26
S2M	2	1-1/2" MNPT x 1-1/2"	115/230	94028297	35
Fittings kit contains (2) 1-1/2" slip x threaded connection union halves				31175608	1

Note: Set of union halves must be purchased separately. Weight in pounds.

Non-Submersible Pumps

S Series Non-Corrosive Centrifugal Pumps

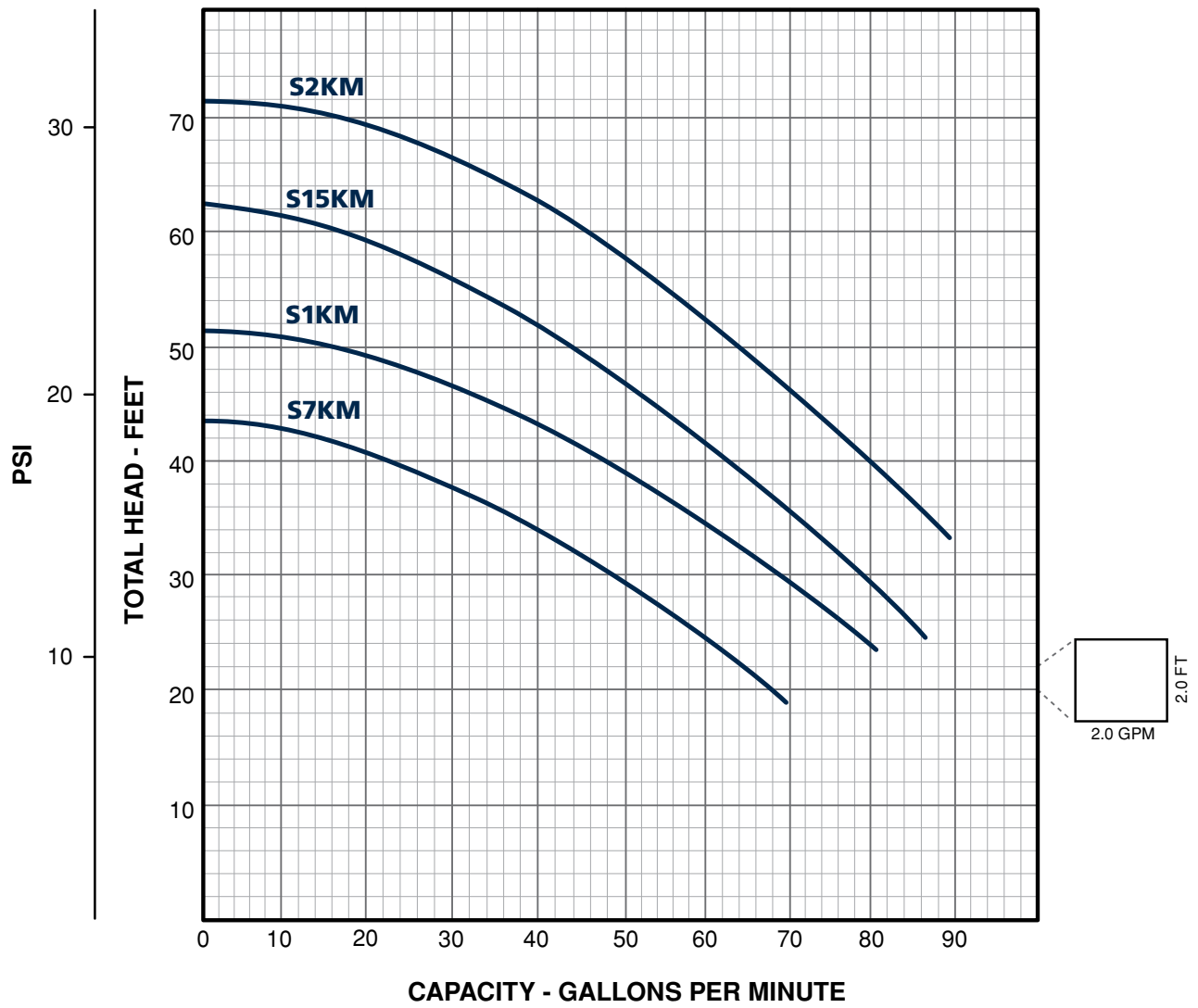

Non-Submersible Pumps

JCM Series Non-Corrosive Centrifugal Pumps - Features



Features:

- Air-cooled heat sink allows pump to run dry without damage to the shaft seal.
- Floating eye seal between the closed impeller and the pump case maximizes pump efficiency for best flow and pressure.
- Accepts a 1.5" standard union. Union adapter kits must be ordered separately.
- UL and CSA agency listings do not apply to any application other than water applications.

Dimensions	
HP	A
3/4	16-5/8"
1	16-5/8"
1.5	17-1/16"
2	17-1/16"

Note: Dimensions will vary according to motor manufacturer.

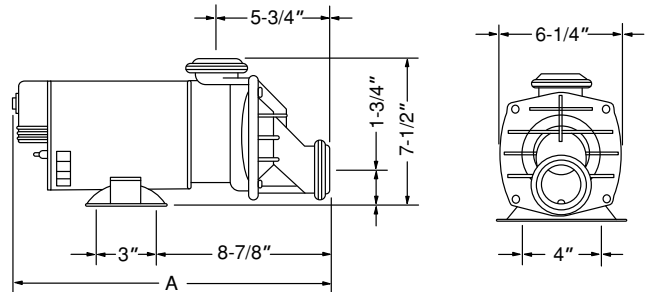

Ordering Information

JCM Series with Straight Union Fit - Single Speed							
Model	HP	Order No.	Discharge x Suction	Voltage	Full Load Amps	Svc. Factor	Weight
S7JCM	3/4	94215696	1-1/2" MNPT x 1-1/2"	115	9.8	1	22
S1JCM	1	94215704	1-1/2" MNPT x 1-1/2"	115	9.8	1	24
S15JCM	1.5	94216587	1-1/2" MNPT x 1-1/2"	115	12.4	1	26
S2JCM	2	94215522	1-1/2" MNPT x 1-1/2"	115/230	16.8/8.4	1	35

JCM Series with Straight Union Fit - Single Speed with Built-In Air Switch & 3' Cord with Standard 3 Prong Plug							
Model	HP	Order No.	Discharge x Suction	Voltage	Full Load Amps	Svc. Factor	Weight
S7JCM-A3	3/4	94216405	1-1/2" MNPT x 1-1/2"	115	10.5	1	22
S1JCM-A3	1	94216421	1-1/2" MNPT x 1-1/2"	115	10.5	1	24
S15JCM-A3	1.5	94216603	1-1/2" MNPT x 1-1/2"	115	12.4	1	26
S2JCM-A3	2	94216447	1-1/2" MNPT x 1-1/2"	115	16.0	1	35

Note: Weight in pounds.

Non-Submersible Pumps

JCM Series Non-Corrosive Centrifugal Pumps

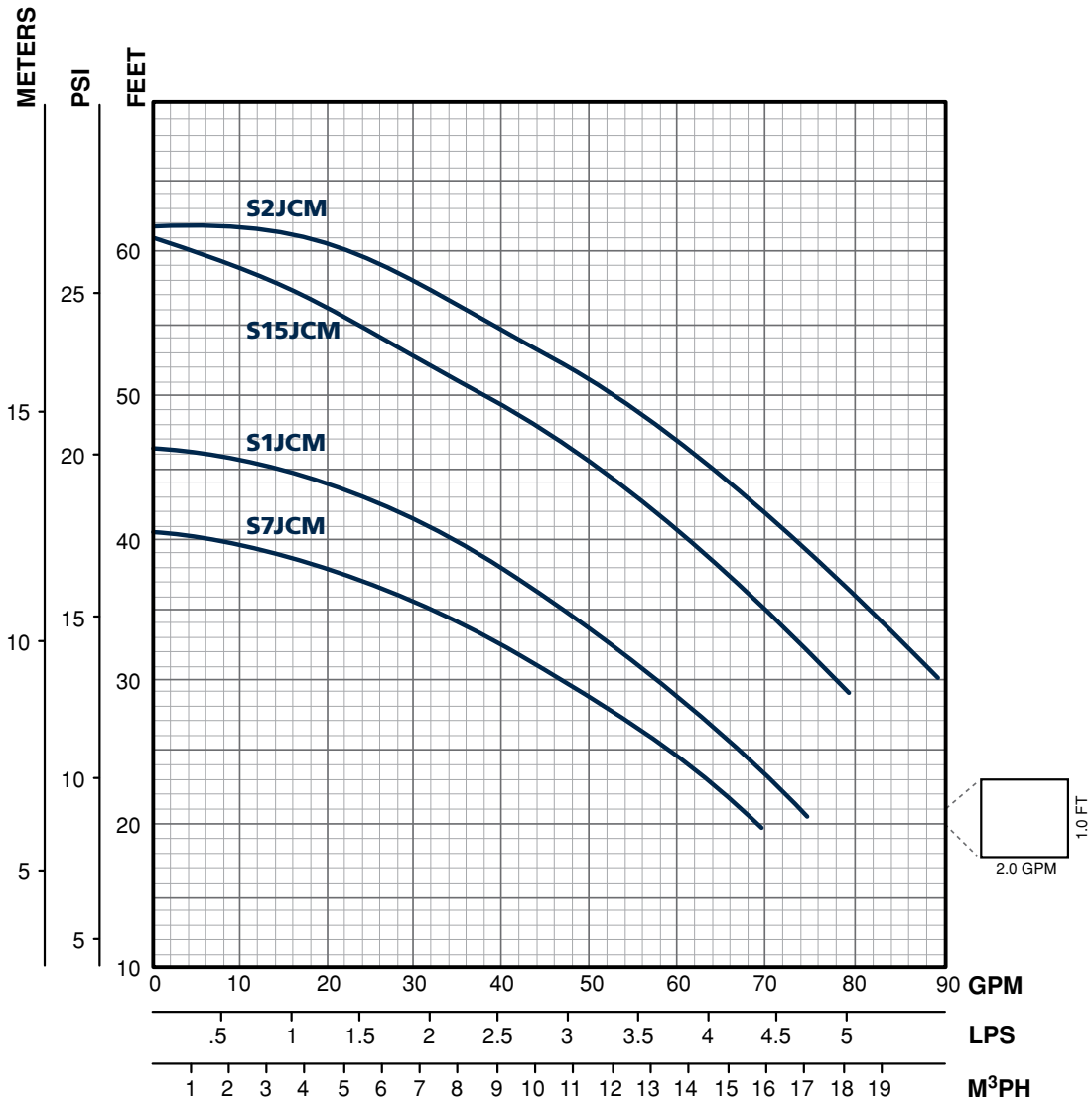

Straight Union	
Model	Order No.
(2) S15UNS Halves	31175608

Note: Must be ordered separately.

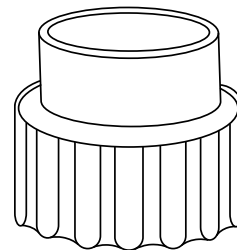

Non-Submersible Pumps

MH Series Horizontal Multi-Stage Centrifugal Pumps



FPS

MH series

The new FPS MH Series, multi-stage booster pump is designed to meet your pressure boosting needs. The stainless steel construction offers high performance in a wide variety of applications. The MH Series is offered in three flow rates and five different horsepower sizes in 1-phase or 3-phase to make sure you have the right pump to fit your application.

Features:

- All 300 series stainless steel wetted components.
- Viton® mechanical shaft seal for added chemical resistance.
- Powered by high quality, industry proven, UL778 approved indoor/outdoor square flange motors.
- Available in 3 flow rates: 15, 30, and 45 gpm.
- 5 motor hp size options in 1-phase or 3-phase.
- High pressure capabilities – 140 psi.
- Able to pump fluids at temperatures up to 225 °F.
- Can operate in suction lift installation up to 10 feet.

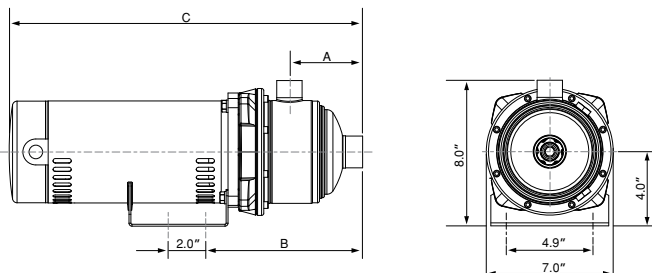

Single-Phase Dimensions				
GPM	Stage	A	B	C
15	2	4.06	8.75	16.75
	3	4.06	8.75	17.50
	4	5.00	9.69	19.07
	5	5.94	10.64	20.81
	6	6.89	11.58	22.59
30	2	4.06	8.75	17.50
	3	4.06	8.75	19.00
	4	5.00	9.69	20.70
	5	5.94	10.64	21.64
45	2	4.65	9.34	19.67
	3	4.65	9.34	20.50

Three-Phase Dimensions				
GPM	Stage	A	B	C
15	2	4.06	8.75	16.97
	3	4.06	8.75	17.62
	4	5.00	9.69	18.92
	5	5.94	10.64	20.78
	6	6.89	11.58	22.56
30	2	4.06	8.75	17.62
	3	4.06	8.75	18.85
	4	5.00	9.69	20.67
	5	5.94	10.64	21.61
45	2	4.65	9.34	19.64
	3	4.65	9.34	20.47

Note: Dimensions will vary according to motor manufacturer.

Viton® is a registered trademark of E.I. du Pont de Nemours and Company

Applications:

- Pressure Boosting
- Water Transfer
- Turf Irrigation
- Residential Lawn Sprinkler Systems
- Wash Down Applications
- Commercial Water Features
- Fountains
- Cisterns
- Reverse Osmosis
- Aeration

Non-Submersible Pumps

MH Series Pumps - Ordering Information

(See pgs. 2-3 for model number explanation)

Single-Phase

GPM	Discharge x Suction	HP	Stage	Voltage	Model No.	Order No.	Wt.
15	1" x 1-1/4"	0.5	2	115/230	15FMH05S2	96061500	22
		0.75	3	115/230	15FMH07S3	96061501	25
		1	4	115/230	15FMH1S4	96061502	29
		1.5	5	115/230	15FMH15S5	96061503	35
		2	6	115/230	15FMH2S6	96061504	40
30	1" x 1-1/4"	0.75	2	115/230	30FMH07S2	96063000	25
		1	3	115/230	30FMH1S3	96063001	33
		1.5	4	115/230	30FMH15S4	96063002	37
		2	5	115/230	30FMH2S5	96063003	41
45	1-1/4" x 1-1/2"	1.5	2	115/230	45FMH15S2	96064500	33
		2	3	115/230	45FMH2S3	96064501	39

Three-Phase

GPM	Discharge x Suction	HP	Stage	Voltage	Model No.	Order No.	Wt.
15	1" x 1-1/4"	0.5	2	208-230/460	15FMH05S2-T	96061510	24
		0.75	3	208-230/460	15FMH07S3-T	96061511	24
		1	4	208-230/460	15FMH1S4-T	96061512	29
		1.5	5	208-230/460	15FMH15S5-T	96061513	34
		2	6	208-230/460	15FMH2S6-T	96061514	42
30	1" x 1-1/4"	0.75	2	208-230/460	30FMH07S2-T	96063010	24
		1	3	208-230/460	30FMH1S3-T	96063011	33
		1.5	4	208-230/460	30FMH15S4-T	96063012	36
		2	5	208-230/460	30FMH2S5-T	96063013	43
45	1-1/4" x 1-1/2"	1.5	2	208-230/460	45FMH15S2-T	96064510	32
		2	3	208-230/460	45FMH2S3-T	96064511	41

Note: Weight in pounds.

Non-Submersible Pumps

MH Series Pumps - 15 GPM

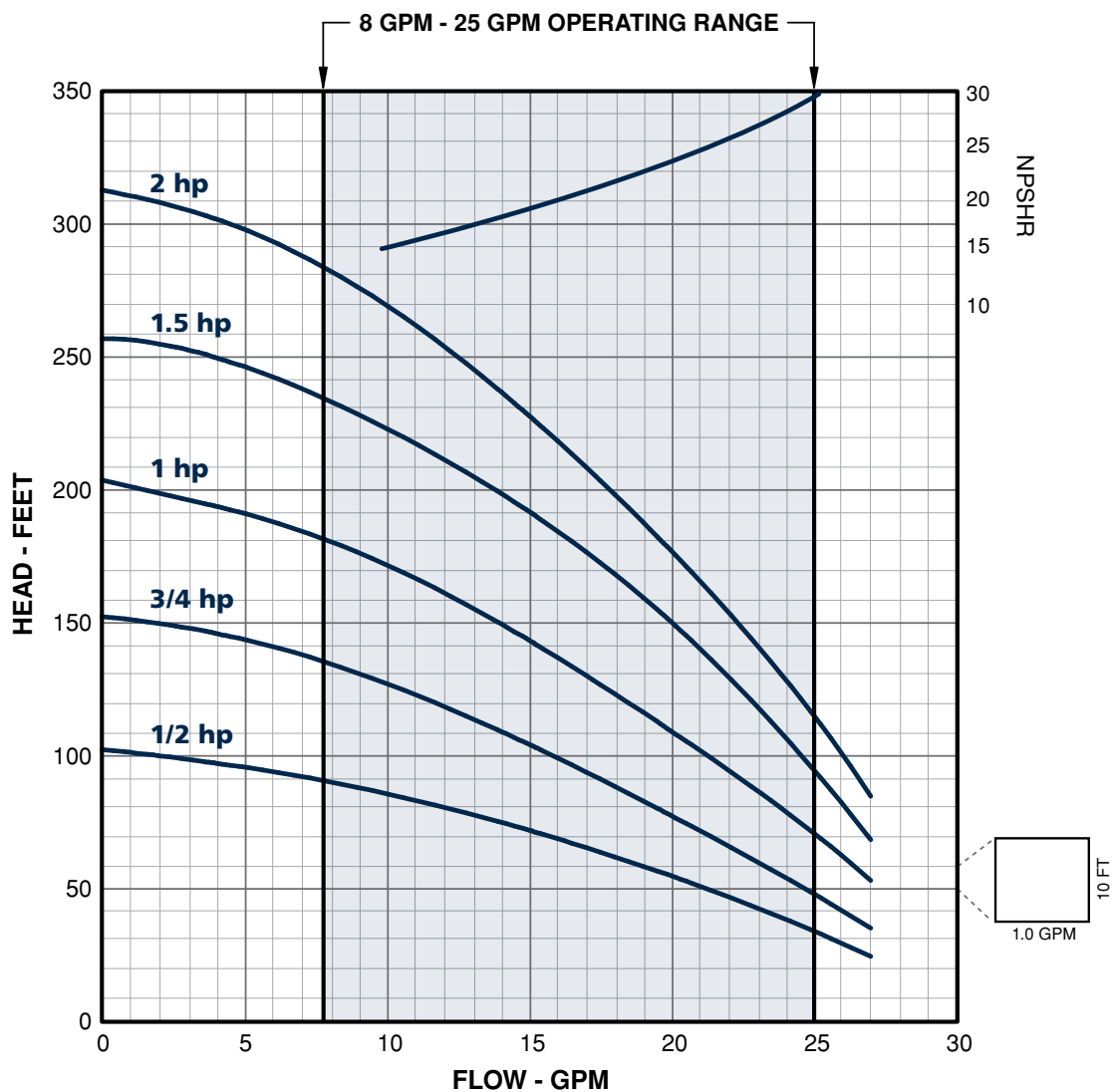

HP	Capacities - GPM																				Shut-off Head (PSI)				
	Total Head - Feet																								
	50	60	70	80	90	100	110	120	130	140	150	160	170	180	190	200	210	220	230	240		250	260	270	
1/2	21	18	15	12	8	1																			44
3/4	25	23	21	19	18	16	14	12	9	6	1														66
1		26	25	24	23	21	20	18	17	15	14	12	10	8	5	1									88
1.5			27	26	25	25	24	23	22	21	20	19	18	16	15	14	12	10	9	6	4				111
2					27	26	25	25	24	23	22	21	21	20	19	18	17	16	15	14	12	11	10		135

Non-Submersible Pumps

MH Series Pumps - 30 GPM

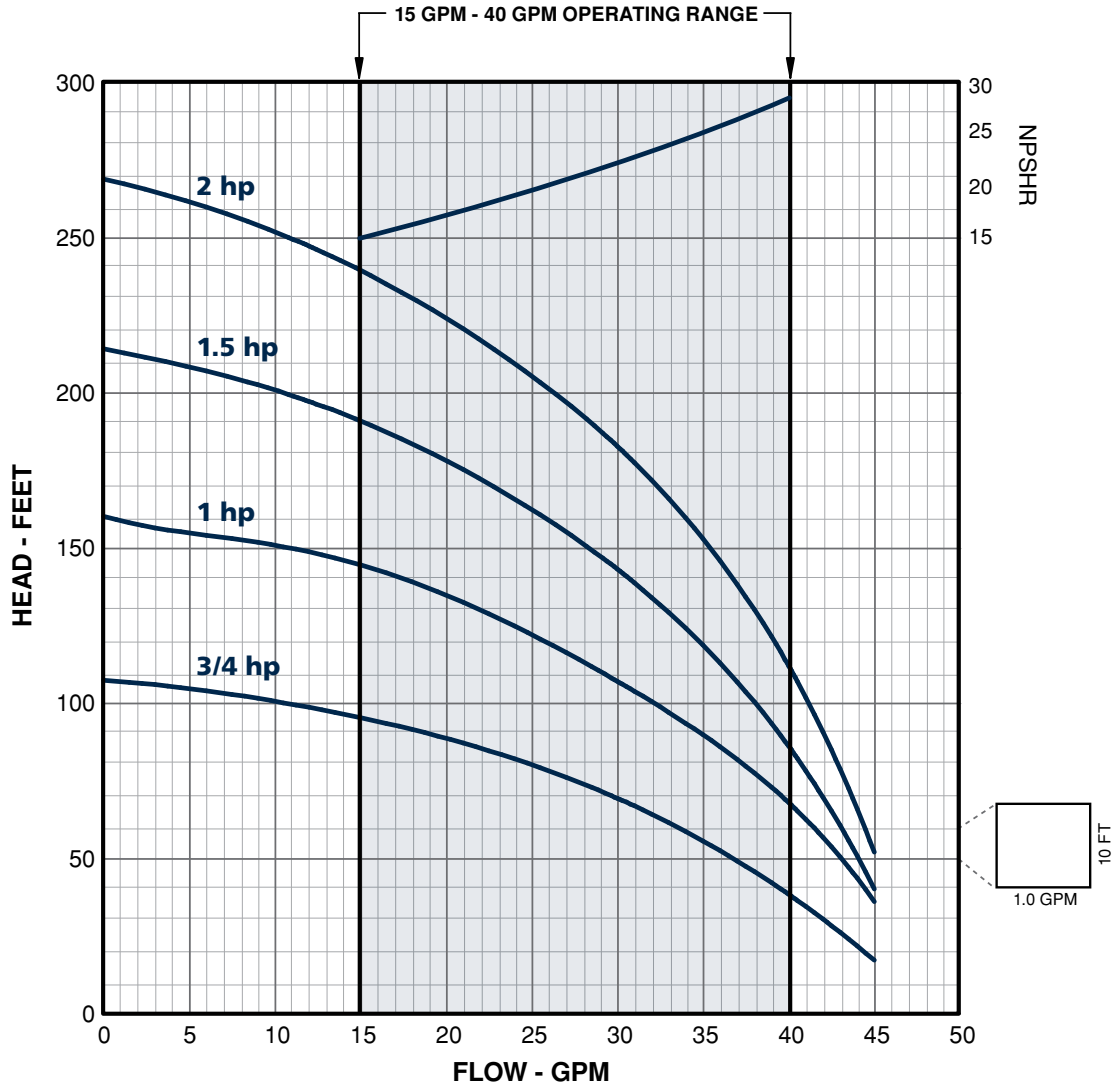

HP	Capacities - GPM																			Shut-off Head (PSI)	
	Total Head - Feet																				
	50	60	70	80	90	100	110	120	130	140	150	160	170	180	190	200	210	220	230		240
3/4	37	33	30	25	19	10															47
1	43	41	40	37	35	32	29	26	22	17	11										69
1.5	44	43	42	41	39	38	36	35	33	31	28	26	23	19	15	10	3				93
2		44	44	43	42	41	40	39	38	37	35	34	32	30	28	26	24	21	18	15	116

Non-Submersible Pumps

MH Series Pumps - 45 GPM

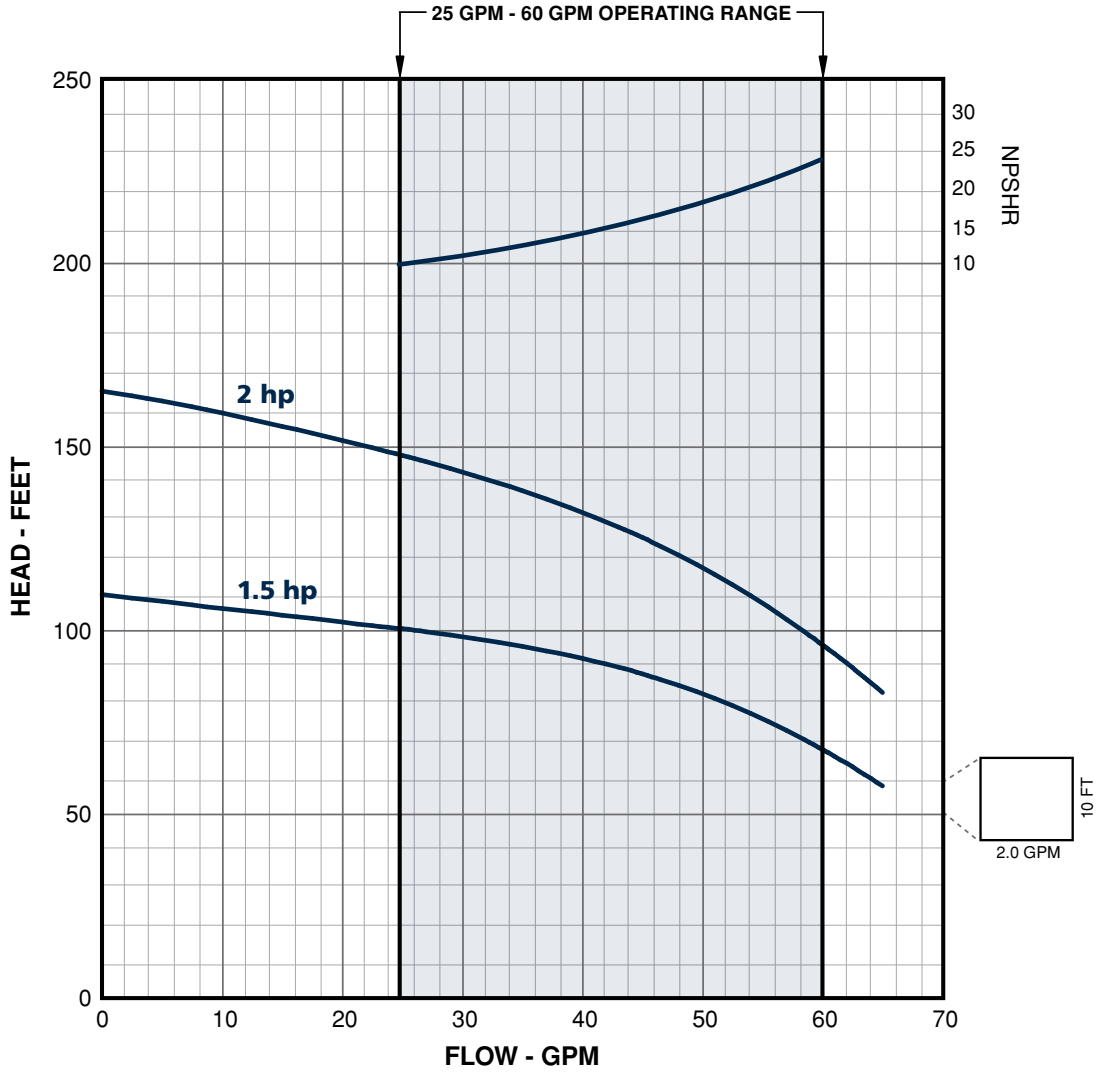

HP	Capacities - GPM											Shut-off Head (PSI)
	Total Head - Feet											
	60	70	80	90	100	110	120	130	140	150	160	
1.5	64	59	52	43	26							47
2				62	58	54	48	42	33	22	9	71

Non-Submersible Pumps

BT4 Series Booster Pumps - Features



CSA ENC 3
COF CSA 3



C US
CSA 108
UL 778

Applications:

- Boosting water pressure from either city mains or private water systems.
- Pressure washing buildings and floors.
- Poultry houses.
- Spray cooling equipment.
- Lawn and crop irrigation.
- Evaporative cooling system/misters.
- Water circulation.
- General purpose pumping.
- Reverse osmosis - stainless steel BT4.
- Filtration - stainless steel BT4.

Note: 3 hp BT4 pumps are for indoor installations only. They are not rated for outdoor installations.

FPS

BT4 series

Cast Iron Features:

- Designed for boosting water pressure from a variety of sources including municipal and private water systems.
- Stainless steel discharge head on all models.
- Cast iron motor bracket with a rugged support foot for horizontal or vertical mounting and a handle for portability of the unit.
- 1" suction and 1" discharge are the same across the entire line, simplifying installation and maintenance.
- The booster pump is built by Franklin Electric's patented (U.S.) Patent 7,290,984) Tri-Seal floating stage system, for maximum efficiency, longevity and performance.
- Assembled with the highest quality materials of construction, such as Celcon® for impellers, Noryl® for the diffusers and 300 series stainless steel for the hub, eye seals, shaft, and shell.
- Easily serviced through a back pull-out design, which leaves all plumbing and the pump undisturbed in their original location.
- Industry proven square flange motors.
- Single-phase: 1/3 through 2 hp motors are dual voltage, set to run with either 115 V or 230 V incoming power, while 3 hp are 230 V only.
- Shut-off pressures up to 270 psi, flow rates from 5 to 25 gpm, and temperatures up to 120 °F / 49 °C.

Stainless Steel Features:

Includes all of the cast iron features above plus:

- Stainless steel models:
 - Viton® mechanical seal for corrosive fluids
 - Three-phase also available: 1/2 through 3 hp motors are dual voltage set to run with either 208-230 V or 460 V incoming power.
- Stainless steel motor bracket with a rugged support foot for horizontal or vertical mounting, and a handle for portability of the unit.
- Designed for industrial applications.

Celcon® is a registered trademark of the Celanese Corporation.

Noryl® is a registered trademark of G.E.

Viton® is a registered trademark of Dupont Dow Elastomers.

Non-Submersible Pumps

BT4 Series Booster Pumps - Ordering Information

(See pgs. 2-3 for model number explanation)

Single-Phase Stainless Steel (With Viton® mechanical seal)

GPM	HP	Discharge x Suction	Voltage	Model No.	Order No.	Wt.
5	1/3	1" x 1"	115/230	5FBT03S4	95830505	33
	1/2	1" x 1"	115/230	5FBT05S4	95830510	37
	3/4	1" x 1"	115/230	5FBT07S4	95830515	41
	1	1" x 1"	115/230	5FBT1S4	95830520	46
7	1/2	1" x 1"	115/230	7FBT05S4	95830710	37
	3/4	1" x 1"	115/230	7FBT07S4	95830715	40
	1	1" x 1"	115/230	7FBT1S4	95830720	46
	1.5	1" x 1"	115/230	7FBT15S4	95830725	53
10	1/2	1" x 1"	115/230	10FBT05S4	95831010	37
	3/4	1" x 1"	115/230	10FBT07S4	95831015	39
	1	1" x 1"	115/230	10FBT1S4	95831020	45
	1.5	1" x 1"	115/230	10FBT15S4	95831025	52
	2	1" x 1"	115/230	10FBT2S4	95831030	56
15	3/4	1" x 1"	115/230	15FBT07S4	95831515	39
	1	1" x 1"	115/230	15FBT1S4	95831520	44
	1.5	1" x 1"	115/230	15FBT15S4	95831525	49
	2	1" x 1"	115/230	15FBT2S4	95831530	55
20	3/4	1" x 1"	115/230	20FBT07S4	95832015	39
	1	1" x 1"	115/230	20FBT1S4	95832020	44
	1.5	1" x 1"	115/230	20FBT15S4	95832025	51
	2	1" x 1"	115/230	20FBT2S4	95832030	55
	3	1" x 1"	230	20FBT3S4	95832035	67
25	1	1" x 1"	115/230	25FBT1S4	95832520	44
	1.5	1" x 1"	115/230	25FBT15S4	95832525	48
	2	1" x 1"	115/230	25FBT2S4	95832530	54
	3	1" x 1"	230	25FBT3S4	95832535	66

Viton® is a registered trademark of Dupont Dow Elastomers.

Single-Phase Cast Iron

GPM	HP	Discharge x Suction	Voltage	Model No.	Order No.	Wt.
5	1/3	1" x 1"	115/230	5FBT03C4	95870501	36
	1/2	1" x 1"	115/230	5FBT05C4	95880505	40
	3/4	1" x 1"	115/230	5FBT07C4	95880510	43
	1	1" x 1"	115/230	5FBT1C4	95880515	49
7	1/2	1" x 1"	115/230	7FBT05C4	95880705	40
	3/4	1" x 1"	115/230	7FBT07C4	95880710	43
	1	1" x 1"	115/230	7FBT1C4	95880715	48
	1.5	1" x 1"	115/230	7FBT15C4	95880720	56
10	1/2	1" x 1"	115/230	10FBT05C4	95881005	39
	3/4	1" x 1"	115/230	10FBT07C4	95881010	42
	1	1" x 1"	115/230	10FBT1C4	95881015	48
	1.5	1" x 1"	115/230	10FBT15C4	95881020	55
	2	1" x 1"	115/230	10FBT2C4	95881025	59
15	3/4	1" x 1"	115/230	15FBT07C4	95881510	41
	1	1" x 1"	115/230	15FBT1C4	95881515	47
	1.5	1" x 1"	115/230	15FBT15C4	95881520	52
	2	1" x 1"	115/230	15FBT2C4	95881525	58
20	3/4	1" x 1"	115/230	20FBT07C4	95882010	41
	1	1" x 1"	115/230	20FBT1C4	95882015	47
	1.5	1" x 1"	115/230	20FBT15C4	95882020	54
	2	1" x 1"	115/230	20FBT2C4	95882025	58
	3	1" x 1"	230	20FBT3C4	95882035	70
25	1	1" x 1"	115/230	25FBT1C4	95882515	46
	1.5	1" x 1"	115/230	25FBT15C4	95882520	51
	2	1" x 1"	115/230	25FBT2C4	95882525	57
	3	1" x 1"	230	25FBT3C4	95882535	69

Note: Weight in pounds.

Non-Submersible Pumps

BT4 Series Booster Pumps - Ordering Information

(See pgs. 2-3 for model number explanation)

Three-Phase Stainless Steel

GPM	HP	Discharge x Suction	Voltage	Model No.	Order No.	Wt.
5	1/2	1" x 1"	208-230/460	5FBT05S4-T	95830555	37
	3/4	1" x 1"	208-230/460	5FBT07S4-T	95830560	41
	1	1" x 1"	208-230/460	5FBT1S4-T	95830565	46
7	1/2	1" x 1"	208-230/460	7FBT05S4-T	95830755	37
	3/4	1" x 1"	208-230/460	7FBT07S4-T	95830760	40
	1	1" x 1"	208-230/460	7FBT1S4-T	95830765	46
	1.5	1" x 1"	208-230/460	7FBT15S4-T	95830770	53
10	1/2	1" x 1"	208-230/460	10FBT05S4-T	95831055	37
	3/4	1" x 1"	208-230/460	10FBT07S4-T	95831060	39
	1	1" x 1"	208-230/460	10FBT1S4-T	95831065	45
	1.5	1" x 1"	208-230/460	10FBT15S4-T	95831070	52
	2	1" x 1"	208-230/460	10FBT2S4-T	95831075	56
15	3/4	1" x 1"	208-230/460	15FBT07S4-T	95831560	39
	1	1" x 1"	208-230/460	15FBT1S4-T	95831565	44
	1.5	1" x 1"	208-230/460	15FBT15S4-T	95831570	49
	2	1" x 1"	208-230/460	15FBT2S4-T	95831575	55
20	3/4	1" x 1"	208-230/460	20FBT07S4-T	95832060	39
	1	1" x 1"	208-230/460	20FBT1S4-T	95832065	44
	1.5	1" x 1"	208-230/460	20FBT15S4-T	95832070	51
	2	1" x 1"	208-230/460	20FBT2S4-T	95832075	55
	3	1" x 1"	208-230/460	20FBT3S4-T	95832080	67
25	1	1" x 1"	208-230/460	25FBT1S4-T	95832565	44
	1.5	1" x 1"	208-230/460	25FBT15S4-T	95832570	48
	2	1" x 1"	208-230/460	25FBT2S4-T	95832575	54
	3	1" x 1"	208-230/460	25FBT3S4-T	95832580	66

Note: Weight in pounds.

BT4 Pump End:

GPM	HP	Discharge x Suction	Model No.	Order No.	Wt.
5	1/3	1" x 1"	5BT03S4-PE	95920507	18
	1/2	1" x 1"	5BT05S4-PE	95920509	19
	3/4	1" x 1"	5BT07S4-PE	95920512	20
	1	1" x 1"	5BT1S4-PE	95920515	21
7	1/2	1" x 1"	7BT05S4-PE	95920708	18
	3/4	1" x 1"	7BT07S4-PE	95920710	19
	1	1" x 1"	7BT1S4-PE	95920714	20
	1.5	1" x 1"	7BT15S4-PE	95920719	24
10	1/2	1" x 1"	10BT05S4-PE	95921007	18
	3/4	1" x 1"	10BT07S4-PE	95921008	19
	1	1" x 1"	10BT1S4-PE	95921011	20
	1.5	1" x 1"	10BT15S4-PE	95921015	23
	2	1" x 1"	10BT2S4-PE	95921018	24
15	3/4	1" x 1"	15BT07S4-PE	95921506	18
	1	1" x 1"	15BT1S4-PE	95921508	19
	1.5	1" x 1"	15BT15S4-PE	95921512	20
	2	1" x 1"	15BT2S4-PE	95921515	23
20	3/4	1" x 1"	20BT07S4-PE	95922005	18
	1	1" x 1"	20BT1S4-PE	95922007	19
	1.5	1" x 1"	20BT15S4-PE	95922010	20
	2	1" x 1"	20BT2S4-PE	95922012	23
	3	1" x 1"	20BT3S4-PE	95922015	24
25	1	1" x 1"	25BT1S4-PE	95922506	18
	1.5	1" x 1"	25BT15S4-PE	95922508	19
	2	1" x 1"	25BT2S4-PE	95922510	20
	3	1" x 1"	25BT3S4-PE	95922513	24

Notes: All weights in pounds. 56Z motor size frame. BT4 pump ends are stainless steel construction.

Non-Submersible Pumps

BT4 Series Booster Pumps - 5 GPM

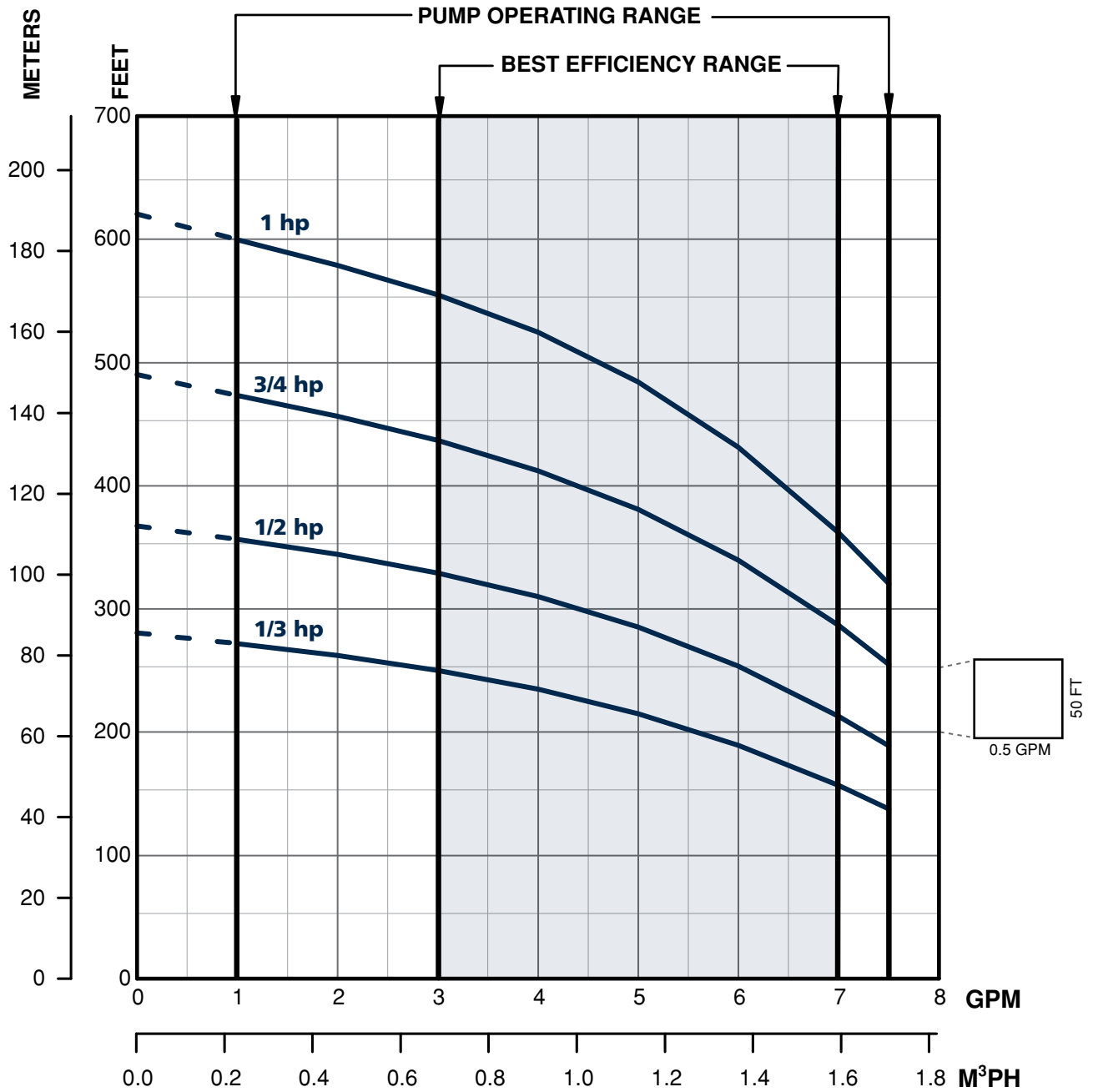

Non-Submersible Pumps

BT4 Series Booster Pumps - 7 GPM

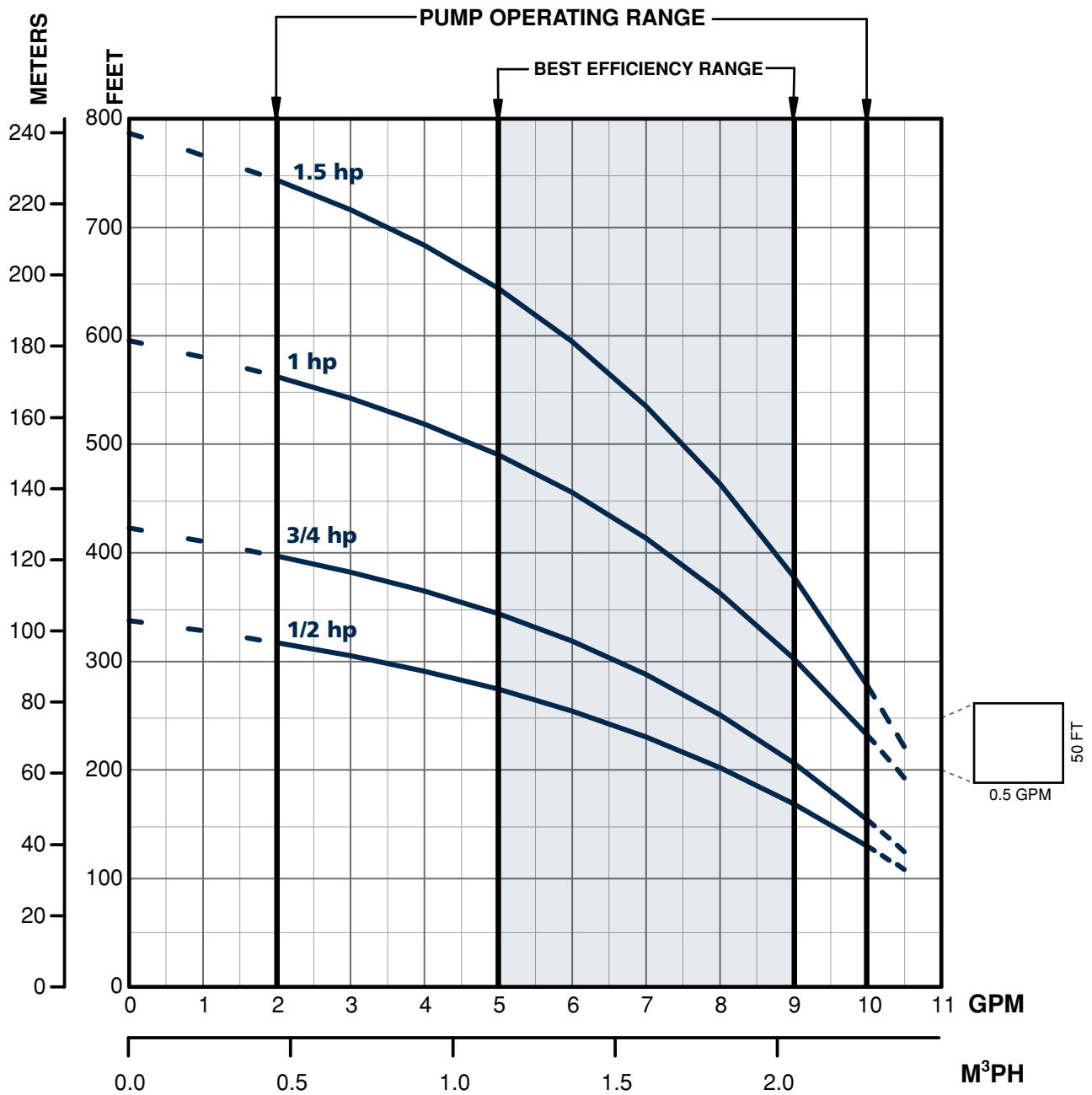

Non-Submersible Pumps

BT4 Series Booster Pumps - 10 GPM

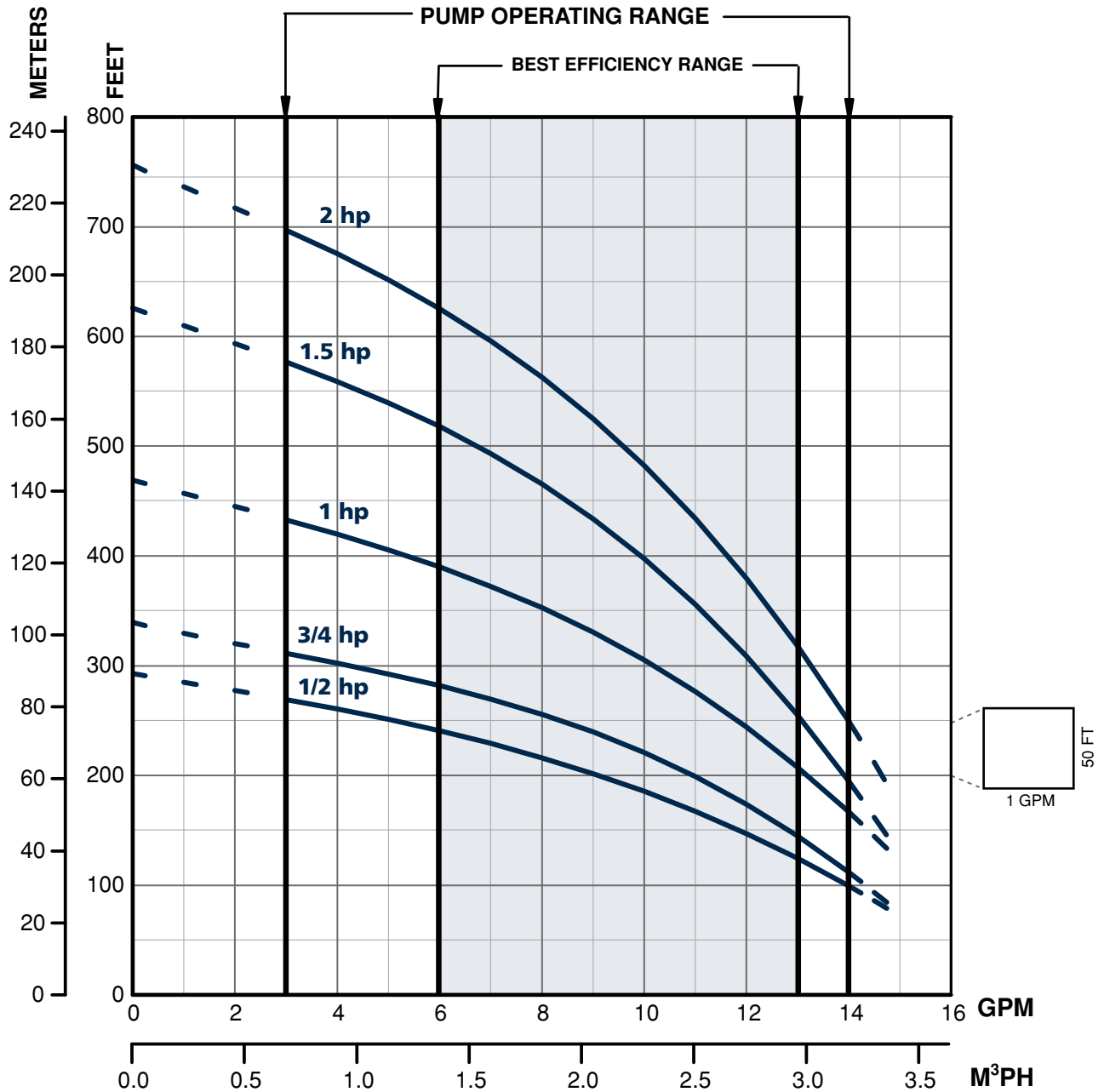

Non-Submersible Pumps

BT4 Series Booster Pumps - 15 GPM

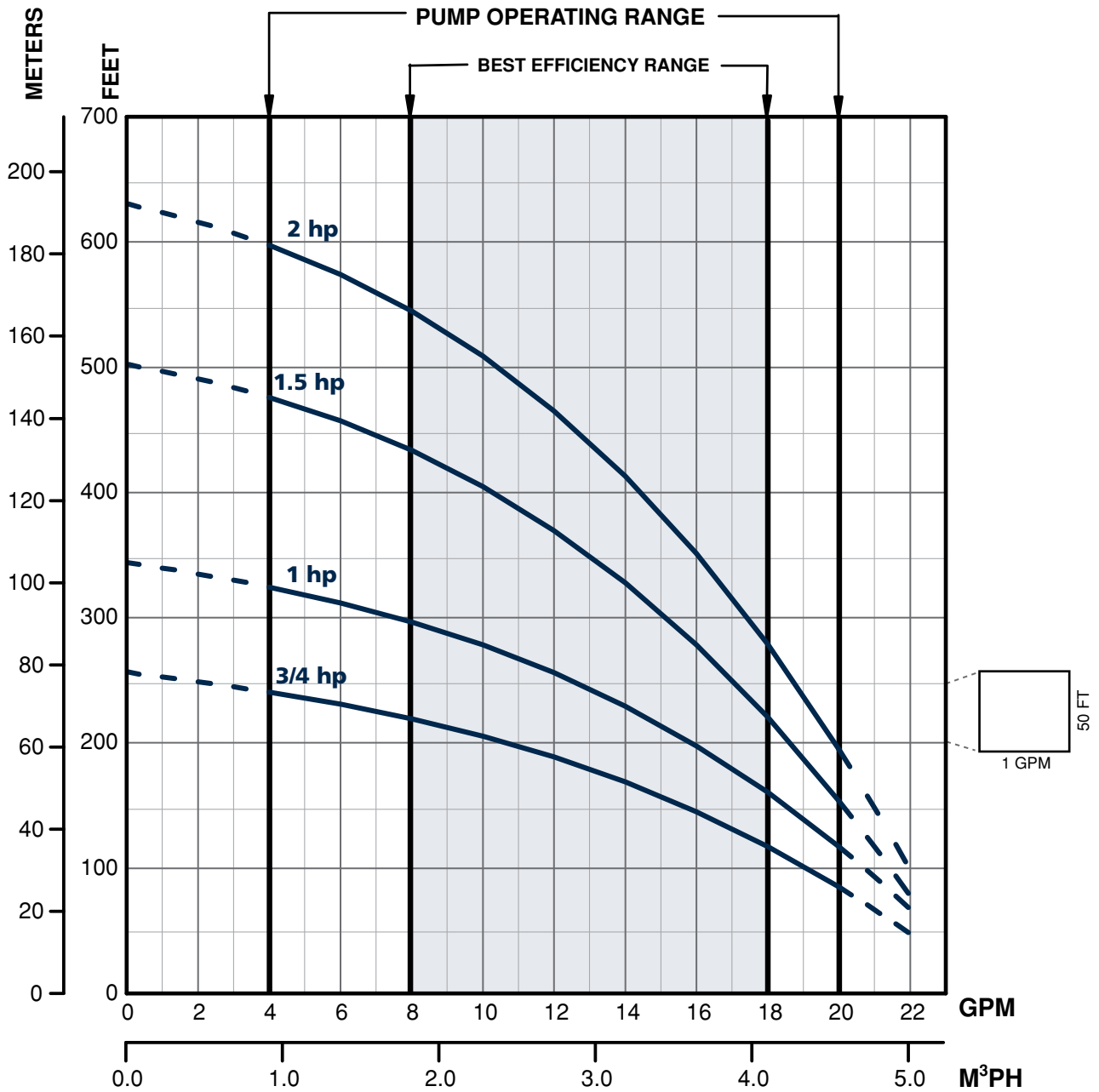

Non-Submersible Pumps

BT4 Series Booster Pumps - 20 GPM

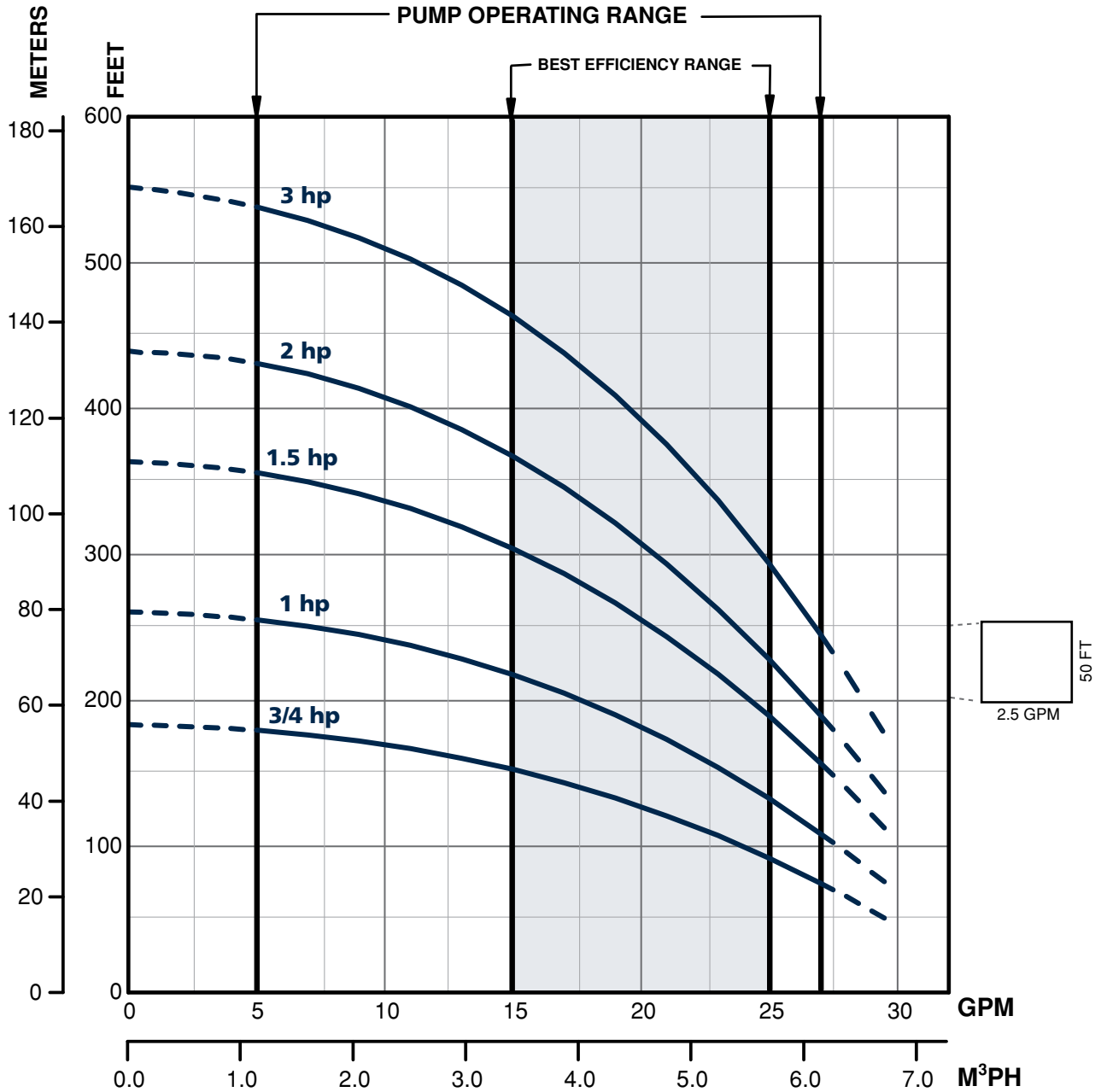

Non-Submersible Pumps

BT4 Series Booster Pumps - 25 GPM

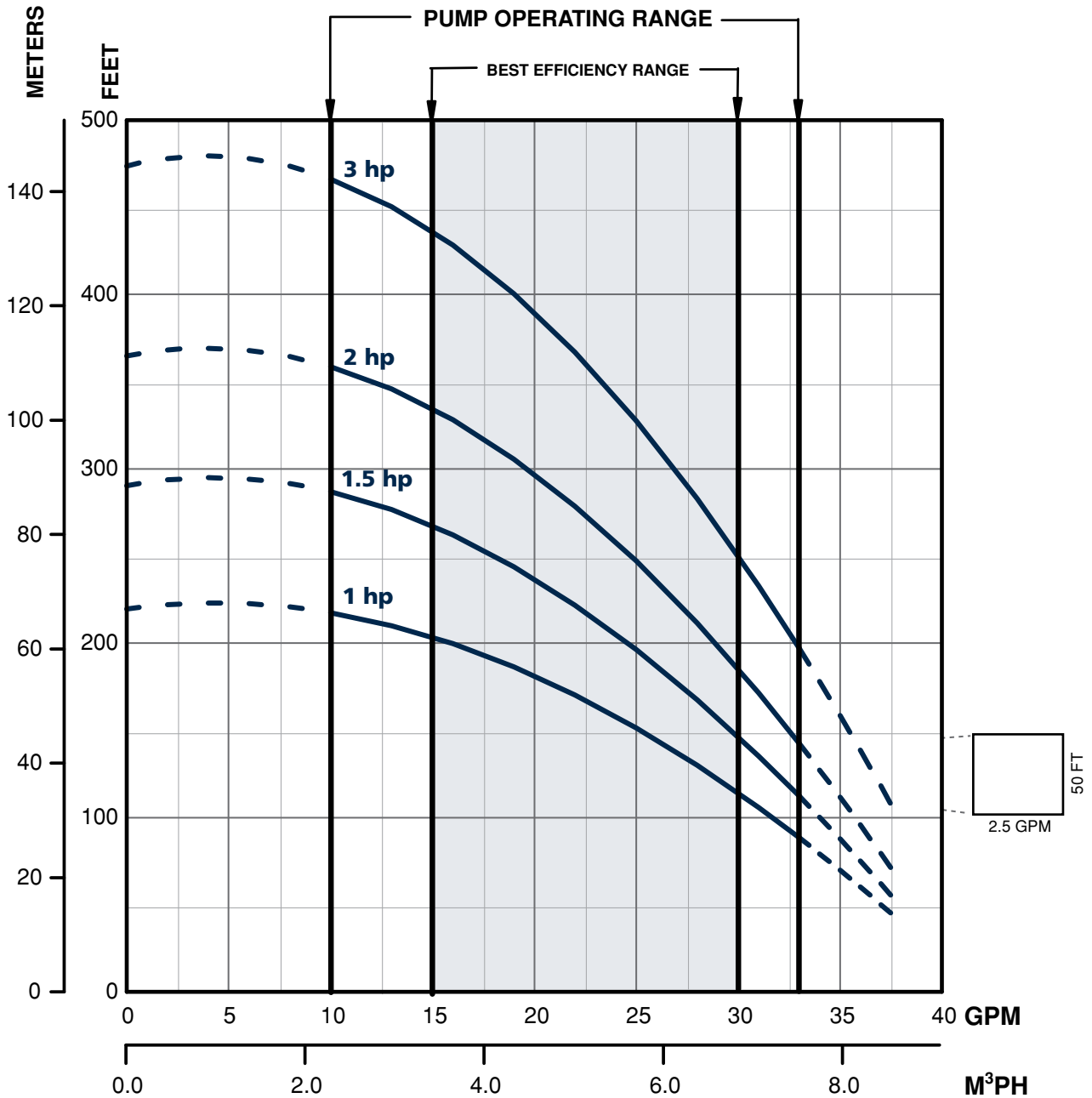

Non-Submersible Pumps

BT4 Series Booster Pumps

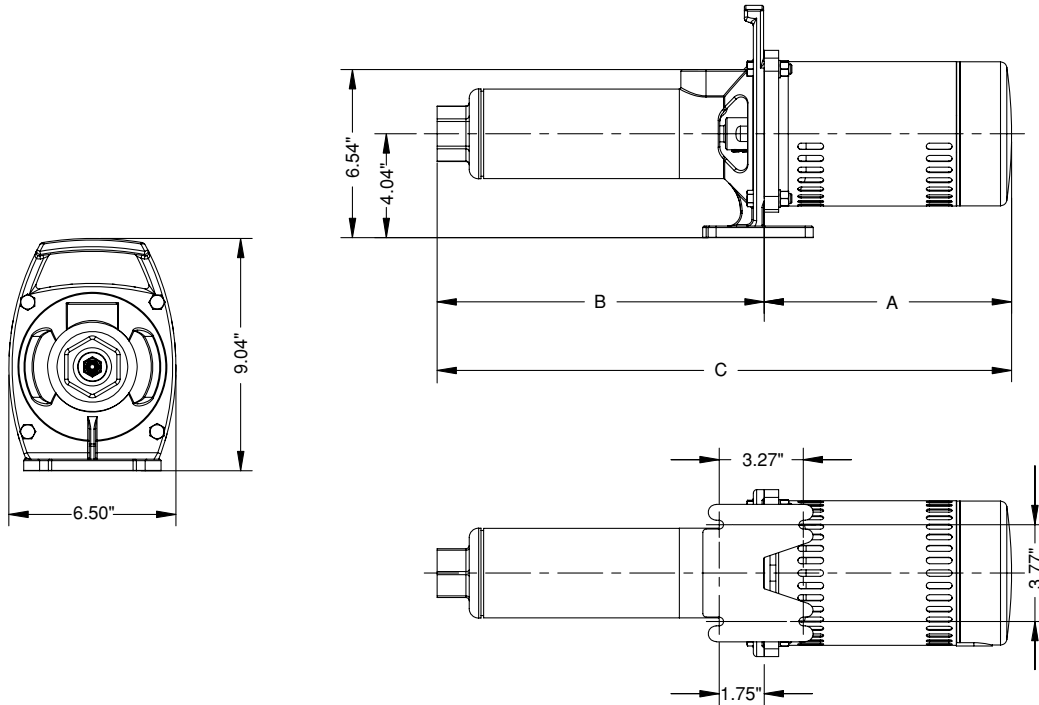

Single-Phase Stainless Steel & Cast Iron:

GPM	HP	Stage	A	B	C
5	1/3	7	9.63"	13.49"	23.12"
	1/2	9	10.38"	15.14"	25.52"
	3/4	12	11.00"	17.60"	28.60"
	1	15	11.88"	20.06"	31.94"
7	1/2	8	10.38"	14.31"	24.69"
	3/4	10	11.00"	15.96"	26.69"
	1	14	11.88"	19.24"	31.12"
	1.5	19	12.63"	23.35"	35.98"
10	1/2	7	10.38"	14.07"	24.45"
	3/4	8	11.00"	14.98"	25.98"
	1	11	11.88"	17.69"	29.57"
	1.5	15	12.63"	21.31"	33.94"
	2	18	12.63"	24.02"	36.65"
15	3/4	6	11.00"	13.17"	24.17"
	1	8	11.88"	14.98"	26.86"
	1.5	12	12.63"	18.59"	31.22"
	2	15	12.63"	21.31"	23.94"
20	3/4	5	11.00"	13.87"	24.87"
	1	7	11.88"	16.31"	28.19"
	1.5	10	12.63"	19.99"	32.62"
	2	12	12.63"	22.43"	35.06"
	3	15	13.18"	26.11"	39.29"
25	1	6	11.88"	15.09"	26.97"
	1.5	8	12.63"	17.54"	30.17"
	2	10	12.63"	19.99"	32.62"
	3	13	13.18"	23.66"	36.84"

Three-Phase Stainless Steel:

GPM	HP	Stage	A	B	C
5	1/2	9	9.85"	15.14"	24.99"
	3/4	12	10.50"	17.60"	28.10"
	1	15	10.85"	20.03"	30.88"
7	1/2	8	9.85"	14.00"	23.85"
	3/4	10	10.50"	14.31"	24.81"
	1	14	10.85"	15.96"	26.81"
	1.5	19	11.85"	23.35"	35.20"
10	1/2	7	9.85"	14.07"	23.92"
	3/4	8	10.50"	14.98"	25.48"
	1	11	10.85"	17.69"	28.54"
	1.5	15	11.85"	21.31"	33.16"
	2.0	18	12.60"	24.02"	36.62"
15	3/4	6	10.50"	13.17"	23.67"
	1	8	10.85"	14.98"	25.83"
	1.5	12	11.85"	18.59"	30.44"
	2	15	12.60"	21.31"	33.91"
20	3/4	5	10.50"	13.87"	24.37"
	1	7	10.85"	16.31"	27.16"
	1.5	10	11.85"	19.99"	31.84"
	2	12	12.60"	22.43"	35.03"
	3	15	12.69"	26.11"	38.80"
25	1	6	10.85"	15.09"	25.94"
	1.5	8	11.85"	17.54"	29.39"
	2	10	12.60"	19.99"	32.59"
	3	13	12.69"	23.66"	36.35"

SubDrive Inline 1100 Constant Pressure Systems - Features



SubDrive Inline 1100

Franklin Electric's SubDrive Inline 1100 provides constant pressure for both private wells and municipal/city water systems.

Features:

- A complete and packaged system.
 - Pump, motor, drive, and pressure switch in one box
- Small and compact design.
 - Fits into small areas, even between floor joists.
- Stainless steel construction.
 - Made for years of operation.
- Simple and easy installation.
 - Step-by-step illustrated instructions.
- Quiet and cool operation.
 - Integrated motor design allows water to flow around it.
- NEMA 4 electronics enclosure.
- Multiple mounting configurations.
 - Lets you install the unit where you need it: horizontal, vertical & even upside down.
- Product power rating: 1.2 hp, 0.9 kW.
- Shipping weight: 50 lbs, 22.7 kg.
- Built in system protections guard the Inline unit from many common failure modes including: surge protection, voltage underload, locked pump, open circuit, short circuit, and overheated controller.

Applications:

- Boosted and constant water pressure from water storage/cistern systems
- Homes - both in private and municipal applications
- General pressure boosting
- Sprinkler systems
- Farming and commercial wash down systems

Ordering Information

Model Description	Order No.	Input Voltage	Input Phase
25SDIL1100N4 ¹	90401101	230	Single
Drive Assembly	305707901	230	Single
Pump Motor Assembly	305707902	230	Single
Mounting Feet	305707903	N/A	N/A
Pressure Switch	305707906	N/A	N/A
Pressure Tank (2-gallon)	305707910	N/A	N/A
Fastener Kit	305707904	N/A	N/A
Pressure Switch Cable	305707905	N/A	N/A
Overpressure Switch ²	305707909	N/A	N/A
Overpressure Switch Cable ²	305707908	N/A	N/A
Overpressure Switch & Cable Combo ²	305707912	N/A	N/A

¹ Includes pump, motor, drive, pressure switch, and all cables.

² Overpressure switch is sold as an accessory and is not required for normal operation.

Non-Submersible Pumps

SubDrive Inline 1100 Contant Pressure Systems

Performance Curve

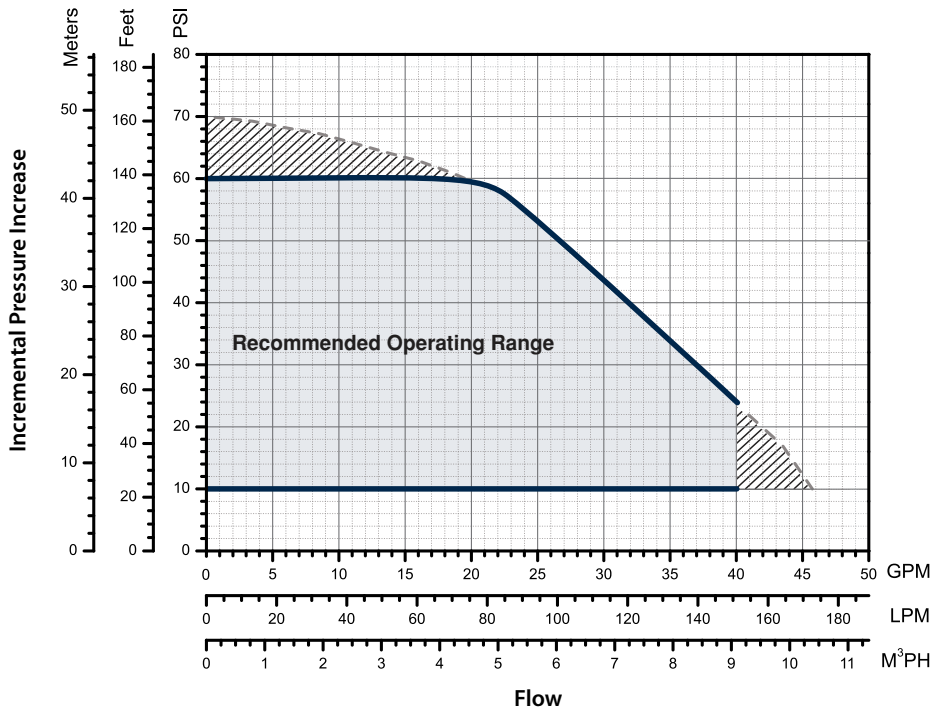

Note: Running outside of 'Recommended Operating Range' for short periods of time is permissible.

System Components

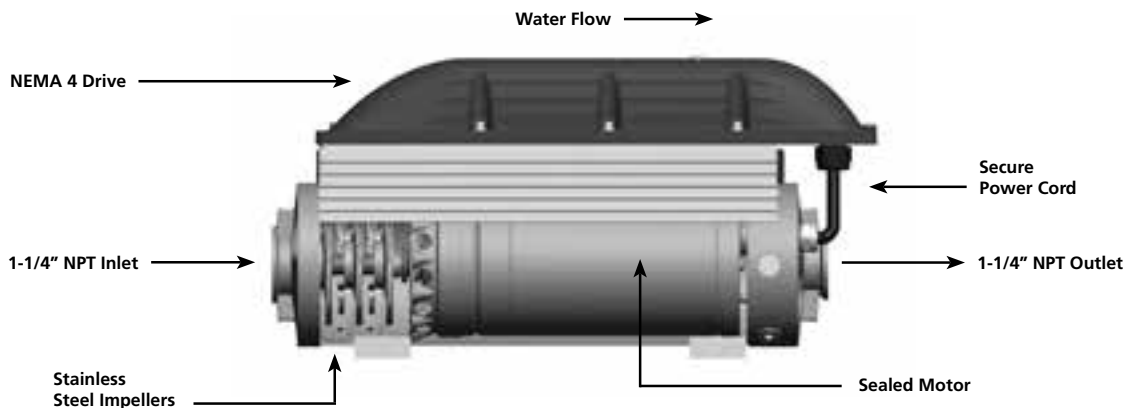

Non-Submersible Pumps

SubDrive Inline 1100 Constant Pressure Systems

Typical Installation

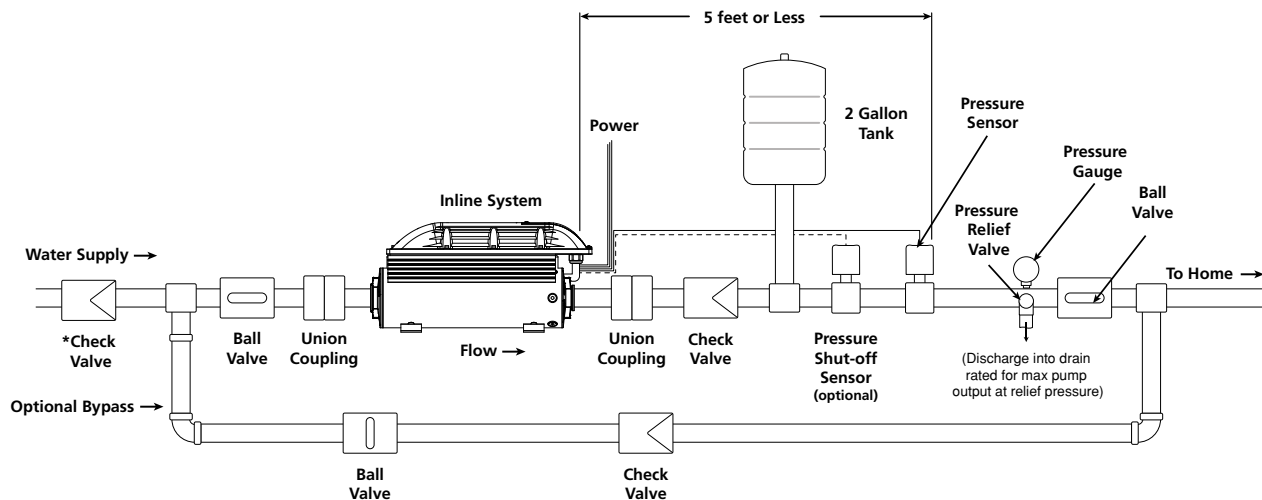

***NOTICE:** If system plumbing does not have a backflow prevention device, a check valve is required on the incoming water supply line.

Note: These optional components are shown in a typical installation diagram. They should be used at the installer's discretion as required for particular applications.

Dimensions

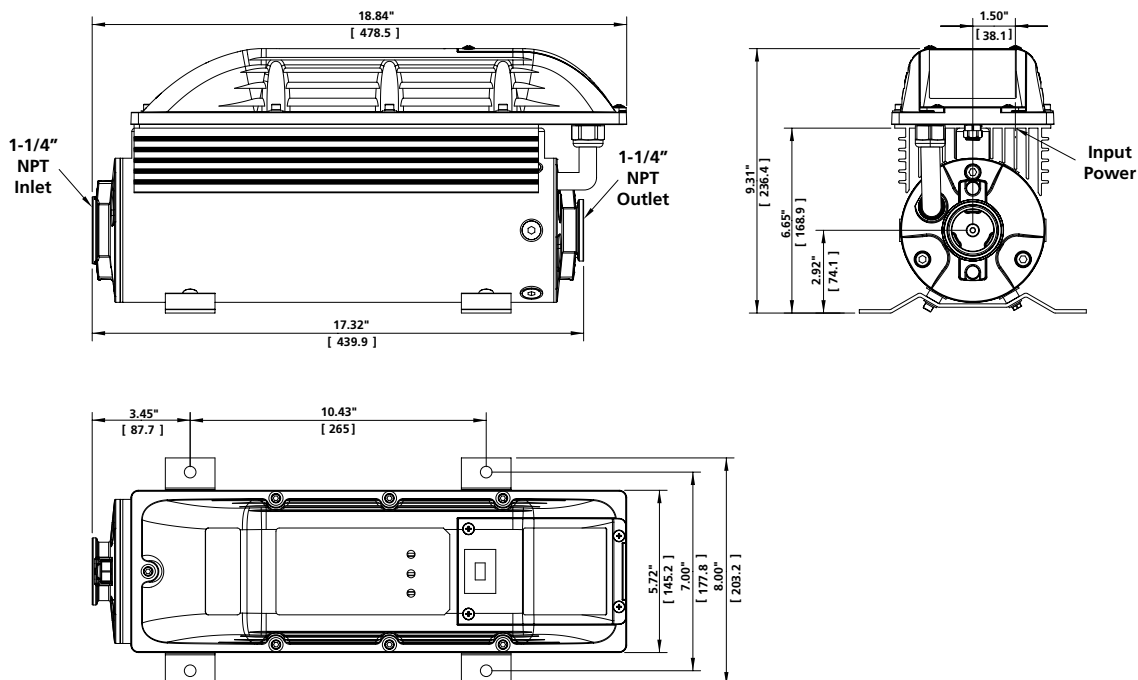

Motors, Drives, Controls & Protection

4" Submersible Motors - 2-Wire Models

HP (kW)	Description						Motor Model	Stock Status	Downward Thrust Rating
	W/PH	Construction	Volts	HZ	S.F.	Lead in motor			
1/3 hp 0.25 kW	2-WIRE	WATER WELL	115	60	1.75		244 502 01--S		300 LBS (1500 N)
			115	60	1.75	YES	244 502 90--S	YES	
			230	60	1.75		244 503 01--S		
			230	60	1.75	YES	244 503 90--S	YES	
		POLLUTION RECOVERY	115	60	1.75		244 502 09--S		
			230	60	1.75		244 503 09--S		
1/2 hp 0.37 kW	2-WIRE	WATER WELL	115	60	1.60		244 504 01--S		300 LBS (1500 N)
			115	60	1.60	YES	244 504 90--S	YES	
			220	50	1.00		244 555 01--S		
			230	60	1.60		244 505 01--S		
			230	60	1.60	YES	244 505 90--S	YES	
		POLLUTION RECOVERY	115	60	1.60		244 504 09--S		
230	60		1.60		244 505 09--S				
3/4 hp 0.55 kW	2-WIRE	WATER WELL	220	50	1.00		244 557 01--S		300 LBS (1500 N)
			230	60	1.50		244 507 01--S		
			230	60	1.50	YES	244 507 90--S	YES	
		POLLUTION RECOVERY	230	60	1.50		244 507 09--S		
1 hp 0.75 kW	2-WIRE	WATER WELL	220	50	1.00		244 558 12--S		650 LBS (3000 N)
			230	60	1.40		244 508 12--S		
			230	60	1.40	YES	244 508 90--S	YES	
		POLLUTION RECOVERY	230	60	1.40		244 508 23--S		
1.5 hp 1.1 kW	2-WIRE	WATER WELL	220	50	1.00		244 359 12--S		650 LBS (3000 N)
			230	60	1.30		244 309 12--S		
			230	60	1.30	YES	244 309 90--S	YES	
		POLLUTION RECOVERY	230	60	1.30		244 309 23--S		

Notes:

1. Pack Designation: --S = Single Pack, available in any quantity. All 3 hp motors are single-packed.
2. Contact factory for lead time for non-stocked items.
3. Pallet packs available but not shown. Please contact customer service for availability.

Motors, Drives, Controls & Protection

4" Submersible Motors - 3-Wire Models

HP (KW)	Description						Motor Model	Control Box Model	Stock Status	Downward Thrust Rating
	W/PH	Construction	Volts	HZ	S.F.	Lead in motor				
1/3 hp 0.25 kW	3-WIRE	WATER WELL	115	60	1.75		214 502 44--S	280 102 49		300 LBS (1500 N)
			115	60	1.75	YES	214 502 90--S	280 102 49	YES	
			220	50	1.00		214 553 41--S	280 353 01		
			230	60	1.75		214 503 44--S	280 103 49		
			230	60	1.75	YES	214 503 90--S	280 103 49	YES	
		POLLUTION RECOVERY	115	60	1.75		214 502 49--S	280 102 49		
			230	60	1.75		214 503 49--S	280 103 49		
1/2 hp 0.37 kW	3-WIRE	WATER WELL	115	60	1.60		214 504 44--S	280 104 49		300 LBS (1500 N)
			115	60	1.60	YES	214 504 90--S	280 104 49	YES	
			220	50	1.00		214 555 41--S	280 355 01	YES	
			230	60	1.60		214 505 44--S	280 105 49		
			230	60	1.60	YES	214 505 90--S	280 105 49	YES	
		POLLUTION RECOVERY	115	60	1.60		214 504 49--S	280 104 49		
			230	60	1.60		214 505 49--S	280 105 49		
3/4 hp 0.55 kW	3-WIRE	WATER WELL	220	50	1.00		214 557 41--S	280 357 01	YES	300 LBS (1500 N)
			230	60	1.50		214 507 44--S	280 107 49		
			230	60	1.50	YES	214 507 90--S	280 107 49	YES	
		POLLUTION RECOVERY	230	60	1.50		214 507 49--S	280 107 49		
		SERIES 600M	230	60	1.50	YES	214 507 0600--S		YES	
1 hp 0.75 kW	3-WIRE	WATER WELL	220	50	1.00		214 558 19--S	280 358 01	YES	650 LBS (3000 N)
			230	60	1.40		214 508 12--S	280 108 49		
			230	60	1.40	YES	214 508 90--S	280 108 49	YES	
		POLLUTION RECOVERY	230	60	1.40		214 508 23--S	280 108 49		
		SERIES 600M	230	60	1.40	YES	214 508 0610--S		YES	
1.5 hp 1.1 kW	3-WIRE	WATER WELL	220	50	1.00		224 350 19--S	282 350 81	YES	650 LBS (3000 N)
			230	60	1.30		224 300 19--S	282 300 81	YES	
			230	60	1.30	YES	224 300 92--S	282 300 81	YES	
		POLLUTION RECOVERY	230	60	1.30		224 300 23--S	282 300 81		
		SERIES 600M	230	60	1.30	YES	224 300 0610--S		YES	
2 hp 1.5 kW	3-WIRE	WATER WELL	220	50	1.00		224 351 19--S	282 351 81	YES	650 LBS (3000 N)
			230	60	1.25		224 301 19--S	282 301 81	YES	
			230	60	1.25	YES	224 301 92--S	282 301 81	YES	
		POLLUTION RECOVERY	230	60	1.25		224 301 23--S	282 301 81		
		SERIES 600M	230	60	1.25	YES	224 301 0610--S		YES	
3 hp 2.2 kW	3-WIRE	WATER WELL	220	50	1.00		224 352 25	282 352 81	YES	900 LBS (4000 N)
			230	60	1.15		224 302 25	282 302 81		
			230	60	1.15	YES	224 302 26	282 302 81	YES	
		SERIES 600M	230	60	1.15	YES	224 302 0620		YES	

Notes:

1. Pack Designation: --S = Single Pack, available in any quantity. All 3 hp motors are single-packed.
2. Contact factory for lead time for non-stocked items.
3. Pallet packs available but not shown. Please contact customer service for availability.

Motors, Drives, Controls & Protection

4" Submersible Motors - Three-Phase Models

HP (KW)	Description						Model	Stock Status	Downward Thrust Rating	
	W/PH	Construction	Volts	HZ	S.F.	Lead in Motor				
½ hp 0.37 kW	3-PHASE	WATER WELL	200	60	1.60		234 501 41--S		300 LBS (1500 N)	
			200	60	1.60	YES	234 501 92--S			
			220	50	1.00		234 551 41--S			
			230	60	1.60		234 511 41--S			
			230	60	1.60	YES	234 511 92--S			
			380/415	50	1.00		234 561 31--S	YES		
			460	60	1.60		234 521 31--S			
			460	60	1.60	YES	234 521 94--S			
		POLLUTION RECOVERY	200	60	1.60		234 501 49--S			
			230	60	1.60		234 511 49--S			
			460	60	1.60		234 521 49--S			
¾ hp 0.55 kW	3-PHASE	WATER WELL	200	60	1.50		234 502 41--S		300 LBS (1500 N)	
			200	60	1.50	YES	234 502 92--S			
			220	50	1.00		234 552 41--S			
			230	60	1.50		234 512 41--S			
			230	60	1.50	YES	234 512 92--S			
			380/415	50	1.00		234 562 31--S	YES		
			460	60	1.50		234 522 31--S			
			460	60	1.50	YES	234 522 94--S			
		POLLUTION RECOVERY	200	60	1.50		234 502 49--S			
			230	60	1.50		234 512 49--S			
			460	60	1.50		234 522 49--S			
		SERIES 600M	230	60	1.50	YES	234 512 0600--S	YES		
			460	60	1.50	YES	234 522 0600--S			
		1 hp 0.75 kW	3-PHASE	WATER WELL	200	60	1.40			234 503 19--S
200	60				1.40	YES	234 503 92--S			
220	50				1.00		234 553 41--S			
230	60				1.40		234 513 19--S			
230	60				1.40	YES	234 513 92--S	YES		
380/415	50				1.00		234 563 31--S	YES		
460	60				1.40		234 523 16--S			
460	60				1.40	YES	234 523 94--S	YES		
POLLUTION RECOVERY	200			60	1.40		234 503 23--S			
	230			60	1.40		234 513 23--S			
	460			60	1.40		234 523 23--S			
SERIES 600M	230			60	1.40	YES	234 513 0610--S	YES		
	460			60	1.40	YES	234 523 0610--S			

Notes:

1. Pack Designation: --S = Single Pack, available in any quantity. All 3 hp motors are single-packed.
2. Contact factory for lead time for non-stocked items.
3. Pallet packs available but not shown. Please contact customer service for availability.

Motors, Drives, Controls & Protection

4" Submersible Motors - Three-Phase Models

HP (KW)	Description						Model	Stock Status	Downward Thrust Rating
	W/PH	Construction	Volts	HZ	S.F.	Lead in Motor			
1.5 hp 1.1 kW	3-PHASE	WATER WELL	200	60	1.30		234 504 19--S		650 LBS (3000 N)
			200	60	1.30	YES	234 504 92--S	YES	
			220	50	1.00		234 554 19--S		
			230	60	1.30		234 514 19--S		
			230	60	1.30	YES	234 514 92--S	YES	
			460/380	60/50	1.30/1.00		234 524 16--S		
			460/380	60/50	1.30/1.00	YES	234 524 94--S	YES	
			575	60	1.30		234 534 16--S		
			575	60	1.30	YES	234 534 94--S	YES	
		POLLUTION RECOVERY	200	60	1.30		234 504 23--S		
			230	60	1.30		234 514 23--S		
			460/380	60/50	1.30/1.00		234 524 23--S		
		SERIES 600M	230	60	1.30	YES	234 514 0610--S	YES	
			460/380	60	1.30/1.00	YES	234 524 0610--S		
2 hp 1.5 kW	3-PHASE	WATER WELL	200	60	1.25		234 305 16--S		650 LBS (3000 N)
			200	60	1.25	YES	234 305 92--S	YES	
			220	50	1.00		234 355 19--S		
			230	60	1.25		234 315 16--S	YES	
			230	60	1.25	YES	234 315 92--S	YES	
			460/380	60/50	1.25/1.00		234 325 16--S	YES	
			460/380	60/50	1.25/1.00	YES	234 325 94--S	YES	
			575	60	1.25		234 335 16--S		
			575	60	1.25	YES	234 335 94--S	YES	
		POLLUTION RECOVERY	200	60	1.25		234 305 23--S		
			230	60	1.25		234 315 23--S		
			460/380	60/50	1.25/1.00		234 325 23--S		
		SERIES 600M	230	60	1.25	YES	234 315 0610--S	YES	
			460/380	60	1.25/1.00	YES	234 325 0610--S		
3 hp 2.2 kW	3-PHASE	WATER WELL	200	60	1.15		234 306 25		900 LBS (4000 N)
			200	60	1.15	YES	234 306 26	YES	
			220	50	1.00		234 356 25		
			230	60	1.15		234 316 25		
			230	60	1.15	YES	234 316 26	YES	
			380	60	1.15		234 346 25		
			380	60	1.15	YES	234 346 26	YES	
			460/380	60/50	1.15/1.00		234 326 25		
			460/380	60/50	1.15/1.00	YES	234 326 26	YES	
			575	60	1.15		234 336 25		
			575	60	1.15	YES	234 336 26	YES	
		SERIES 600M	230	60	1.15	YES	234 316 0620		
			460/380	60	1.15/1.00	YES	234 326 0620		

Motors, Drives, Controls & Protection

4" Submersible Motors - Super Stainless Models

4-Inch Super Stainless Motor Specifications

Hz	Ph	Hp Range	kW Range	Poles	RPM	Max. Ambient Temp.	Duty Rating
60	2-Wire	1/3 - 1.5	0.25 - 1.1	2	3450	86 °F / 30 °C	Continuous
50	2-Wire	1/2 - 1.5	0.37 - 1.1	2	2875	86 °F / 30 °C	Continuous
60	3-Wire	1/3 - 3	0.25 - 2.2	2	3450	86 °F / 30 °C	Continuous*
50	3-Wire	1/3 - 3	0.25 - 2.2	2	2875	86 °F / 30 °C	Continuous*
60	Three-Phase	1/3 - 3	0.37 - 2.2	2	3450	86 °F / 30 °C	Continuous*
50	Three-Phase	1/3 - 3	0.37 - 2.2	2	2875	86 °F / 30 °C	Continuous*

4-Inch Pollution Recovery Motor Specifications

Hz	Ph	Hp Range	kW Range	Poles	RPM	Max. Ambient Temp.	Duty Rating
60	2-Wire	1/3 - 1.5	0.25 - 1.1	2	3450	86 °F / 30 °C	Continuous
50	2-Wire	1/2 - 1.5	0.37 - 1.1	2	2875	86 °F / 30 °C	Continuous
60	3-Wire	1/3 - 2	0.25 - 1.5	2	3450	86 °F / 30 °C	Continuous*
50	3-Wire	1/3 - 2	0.25 - 1.5	2	2875	86 °F / 30 °C	Continuous*
60	Three-Phase	1/2 - 2	0.37 - 1.5	2	3450	86 °F / 30 °C	Continuous*
50	Three-Phase	1/2 - 2	0.37 - 1.5	2	2875	86 °F / 30 °C	Continuous*

* 3 hp motors require 0.25 ft/sec flow past motor.

4-Inch Construction Materials

Component	Construction Type	
	Standard Water Well	Pollution Recovery
Castings	304 SS over Iron	304 SS over Iron
Stator Shell	301 SS	301 SS
Shaft Extension	17-4 SS or 303 SS	303 SS
Fasteners	305 SS or 302 SS	316 SS
Seal Cover	Acetal	Tefzel®
Seal	Nitrile Rubber Lip	Viton®
Diaphragm	Nitrile Rubber	Viton®
Slinger	Nitrile Rubber	Viton®
Lead Wire (or Cable)	XLPE	Lead not furnished with motor
Lead Potting	Epoxy	Lead not furnished with motor
Lead Jam Nut	303 SS	Lead not furnished with motor

Specifications subject to change without notice. Contact Franklin Electric if current material types are required for bid specifications.

Viton® is a registered trademark of DuPont Dow Elastomers.

Tefzel® is a registered trademark of E.I. du Pont Nemours and Company.

Motors, Drives, Controls & Protection

4" Submersible Motors - High Thrust Models

HP (KW)	Description						Model	Stock Status	Downward Thrust Rating
	Construction	PH	Volts	HZ	S.F.	Lead in Motor			
1.5 hp 1.1 kW	WATER WELL	1	230	60	1.30		224 300 8600		1500 LBS (6500 N)
		3	200	60	1.30		234 504 8600		
		3	230	60	1.30		234 514 8600		
		3	460/380	60/50	1.30/1.00		234 524 8600		
		3	575	60	1.30		234 534 8600		
	316 SS	1	230	60	1.30	YES	224 300 8502		
		3	200	60	1.30	YES	234 504 8502		
		3	230	60	1.30	YES	234 514 8502		
		3	460/380	60/50	1.30/1.00	YES	234 524 8502		
		3	575	60	1.30	YES	234 534 8502		
2 hp 1.5 kW	WATER WELL	1	230	60	1.25	YES	224 301 8602		1500 LBS (6500 N)
		3	200	60	1.25		234 305 8600		
		3	230	60	1.25		234 315 8600		
		3	460/380	60/50	1.25/1.00		234 325 8600		
		3	575	60	1.25		234 335 8600		
	SAND FIGHTER	1	230	60	1.15	YES	224 301 8802		
	316 SS	1	230	60	1.25	YES	224 301 8502		
		3	200	60	1.25	YES	234 305 8502		
		3	230	60	1.25	YES	234 315 8502		
		3	460/380	60/50	1.25/1.00	YES	234 325 8502		
		3	575	60	1.25	YES	234 335 8502		
	OIL STRIPPER	1	230	60	1.25	YES	224 301 8702		
		3	230	60	1.25	YES	234 315 8702		
		3	460/380	60/50	1.25/1.00	YES	234 325 8702		

Motors, Drives, Controls & Protection

4" Submersible Motors - High Thrust Models

HP (KW)	Description						Model	Stock Status	Downward Thrust Rating
	Construction	PH	Volts	HZ	S.F.	Lead in Motor			
3 hp 2.2 kW	WATER WELL	1	220	50	1.00		224 352 8600		1500 LBS (6500 N)
		1	230	60	1.15		224 302 8600		
		1	230	60	1.15	YES	224 302 8602		
		3	200	60	1.15		234 306 8600		
		3	200	60	1.15	YES	234 306 8602		
		3	220	50	1.00		234 356 8600		
		3	230	60	1.15		234 316 8600		
		3	230	60	1.15	YES	234 316 8602		
		3	380	60	1.15		234 346 8600		
		3	380	60	1.15	YES	234 346 8602		
		3	460/380	60/50	1.15/1.00		234 326 8600		
		3	460/380	60/50	1.15/1.00	YES	234 326 8602		
		3	575	60	1.15		234 336 8600		
	3	575	60	1.15	YES	234 336 8602			
	COALBEAD METHANE	3	200	60	1.15	YES	234 306 8902		
		3	230	60	1.15	YES	234 316 8902		
		3	460/380	60/50	1.15/1.00	YES	234 326 8902	YES	
		3	575	60	1.15	YES	234 336 8902		
		3	380	60	1.15	YES	234 346 8902		
	SAND FIGHTER	1	230	60	1.15	YES	224 302 8802	YES	
		3	200	60	1.15	YES	234 306 8802		
		3	230	60	1.15	YES	234 316 8802	YES	
		3	460/380	60/50	1.15/1.00	YES	234 326 8802	YES	
		3	575	60	1.15	YES	234 336 8802		
		3	380	60	1.15	YES	234 346 8802		
	SERIES 600M	1	230	60	1.15	YES	224 302 0630	YES	
		3	230	60	1.15	YES	234 316 0630	YES	
		3	460/380	60	1.15/1.00	YES	234 326 0630		
	316 SS	1	230	60	1.15	YES	224 302 8502		
		3	200	60	1.15	YES	234 306 8502		
		3	230	60	1.15	YES	234 316 8502		
		3	460/380	60/50	1.15/1.00	YES	234 326 8502		
		3	575	60	1.15	YES	234 336 8502		
	OIL STRIPPER	1	230	60	1.15	YES	224 302 8702		
		3	230	60	1.15	YES	234 316 8702		
		3	460/380	60/50	1.15/1.00	YES	234 326 8702		
4 hp 3 kW	WATER WELL	3	460/415-380	60/50	1.15/1.00		234 395 8600		
		3	460/415-380	60/50	1.15/1.00	YES	234 395 8602		

Motors, Drives, Controls & Protection

4" Submersible Motors - High Thrust Models

HP (KW)	Description						Model	Stock Status	Downward Thrust Rating
	Construction	PH	Volts	HZ	S.F.	Lead in Motor			
5 hp 3.7 kW	WATER WELL	1	220	50	1.00		224 353 8600	YES	1500 LBS (6500 N)
		1	230	60	1.15		224 303 8600		
		1	230	60	1.15	YES	224 303 8602	YES	
		3	200	60	1.15		234 307 8600		
		3	200	60	1.15	YES	234 307 8602	YES	
		3	220	50	1.00		234 357 8600		
		3	230	60	1.15		234 317 8600		
		3	230	60	1.15	YES	234 317 8602	YES	
		3	380	60	1.15		234 347 8600		
		3	380	60	1.15	YES	234 347 8602		
		3	460/380	60/50	1.15/1.00		234 327 8600	YES	
		3	460/380	60/50	1.15/1.00	YES	234 327 8602	YES	
		3	575	60	1.15		234 337 8600		
	3	575	60	1.15	YES	234 337 8602	YES		
	COALBED METHANE	3	200	60	1.15	YES	234 307 8902		
		3	230	60	1.15	YES	234 317 8902		
		3	460/380	60/50	1.15/1.00	YES	234 327 8902	YES	
		3	575	60	1.15	YES	234 337 8902		
		3	380	60	1.15	YES	234 347 8902		
	SAND FIGHTER	1	230	60	1.15	YES	224 303 8802	YES	
		3	200	60	1.15	YES	234 307 8802		
		3	230	60	1.15	YES	234 317 8802	YES	
		3	460/380	60/50	1.15/1.00	YES	234 327 8802	YES	
		3	575	60	1.15	YES	234 337 8802		
		3	380	60	1.15	YES	234 347 8802		
	SERIES 600M	1	230	60	1.15	YES	224 303 0630	YES	
		3	230	60	1.15	YES	234 317 0630	YES	
		3	460/380	60	1.15/1.00	YES	234 327 0630		
	316 SS	1	230	60	1.15	YES	224 303 8502		
		3	200	60	1.15	YES	234 307 8502		
3		230	60	1.15	YES	234 317 8502			
3		460/380	60/50	1.15/1.00	YES	234 327 8502			
OIL STRIPPER	3	575	60	1.15	YES	234 337 8502			
	1	230	60	1.15	YES	224 303 8702			
	3	230	60	1.15	YES	234 317 8702			
	3	460/380	60/50	1.15/1.00	YES	234 327 8702			
	5.5 hp 4 kW	WATER WELL	3	460/380	60/50	1.15/1.00		234 397 8600	1500 LBS (6500 N)
			3	460/380	60/50	1.15/1.00	YES	234 397 8602	

Motors, Drives, Controls & Protection

4" Submersible Motors - High Thrust Models

HP (KW)	Description						Model	Stock Status	Downward Thrust Rating
	Construction	PH	Volts	HZ	S.F.	Lead in Motor			
7.5 hp 5.5 kW	WATER WELL	3	200	60	1.15		234 308 8600		1500 LBS (6500 N)
		3	200	60	1.15	YES	234 308 8602	YES	
		3	220	50	1.00		234 358 8600		
		3	230	60	1.15		234 318 8600		
		3	230	60	1.15	YES	234 318 8602	YES	
		3	380	60	1.15		234 348 8600		
		3	380	60	1.15	YES	234 348 8602	YES	
		3	460/380	60/50	1.15/1.00		234 328 8600	YES	
		3	460/380	60/50	1.15/1.00	YES	234 328 8602	YES	
		3	575	60	1.15		234 338 8600		
	3	575	60	1.15	YES	234 338 8602	YES		
	COALBED METHANE	3	200	60	1.15	YES	234 308 8904		
		3	230	60	1.15	YES	234 318 8904		
		3	460/380	60/50	1.15/1.00	YES	234 328 8904	YES	
		3	575	60	1.15	YES	234 338 8904		
		3	380	60	1.15	YES	234 348 8904		
	SAND FIGHTER	3	200	60	1.15	YES	234 308 8802		
		3	230	60	1.15	YES	234 318 8802	YES	
		3	460/380	60/50	1.15/1.00	YES	234 328 8802	YES	
		3	575	60	1.15	YES	234 338 8802		
	316 SS	3	380	60	1.15	YES	234 348 8802		
		3	200	60	1.15	YES	234 308 8502		
		3	230	60	1.15	YES	234 318 8502		
		3	460/380	60/50	1.15/1.00	YES	234 328 8502		
OIL STRIPPER	3	575	60	1.15	YES	234 338 8502			
	3	230	60	1.15	YES	234 318 8702			
10 hp 7.5 kW	WATER WELL	3	380	60	1.15	YES	234 549 8602		
		3	460/380	60/50	1.15/1.00	YES	234 595 8602	YES	
		3	575	60	1.15	YES	234 598 8602	YES	
	COALBED METHANE	3	380	60	1.15	YES	234 549 8904		
		3	460/380	60/50	1.15/1.00	YES	234 595 8904	YES	
		3	575	60	1.15	YES	234 598 8904		
	SAND FIGHTER	3	380	60	1.15	YES	234 549 8802		
		3	460/380	60/50	1.15/1.00	YES	234 595 8802	YES	
		3	575	60	1.15	YES	234 598 8802		
	316 SS	3	460/380	60/50	1.15/1.00	YES	234 595 8502		
		3	460/380	60/50	1.15/1.00	YES	234 595 8802		
	OIL STRIPPER	3	460/380	60/50	1.15/1.00	YES	234 595 8802		
15 hp 11.25 kW	COALBED METHANE	3	460/380-415	60/50	1.15/1.00		234 626 8994		3500 LBS

Motors, Drives, Controls & Protection

4" Submersible Motors - High Thrust Models

4-Inch High Thrust Motor Specifications

Hz	Ph	Hp Range	kW Range	Poles	RPM	Max. Ambient Temp.	Duty Rating
60	1	1.5 - 5	1.1 - 3.7	2	3450	86 °F / 30 °C	Continuous at 0.25 ft/sec flow past motor
50	1	1.5 - 5	1.1 - 3.7	2	2875	86 °F / 30 °C	Continuous at 0.25 ft/sec flow past motor
60	3	1.5 - 10	1.1 - 7.5	2	3450	86 °F / 30 °C	Continuous at 0.25 ft/sec flow past motor
50	3	1.5 - 10	1.1 - 7.5	2	2875	86 °F / 30 °C	Continuous at 0.25 ft/sec flow past motor

NOTE: Not all ratings available in all construction options.

4-Inch High Thrust Construction Materials

Component	Construction Type		
	Standard Water Well	Coalbed Methane	Sand Fighter™
Top Castings	303 SS	303 SS	303 SS
Bottom Castings	303 SS Over Painted Cast Iron	303 SS Over Painted Cast Iron	303 SS Over Painted Cast Iron
Stator Shell	301 SS	301 SS	301 SS
Stator Ends	Low Carbon Steel	Low Carbon Steel	Low Carbon Steel
Shaft Extension	17-4 SS	17-4 SS	17-4 SS
Fasteners	300 Series SS	300 Series SS	300 Series SS
Seal Cover	Acetal	Sintered Bronze	Sintered Bronze
Seal	Nitrile Rubber Lip	Sand Fighter™ SiC/ SiC Mech Seal	Sand Fighter SiC/ SiC Mech Seal
Diaphragm	Nitrile Rubber	Nitrile Rubber	Nitrile Rubber
Diaphragm Cup	316 SS	316 SS	316 SS
Diaphragm Spring	316 SS	316 SS	316 SS
Diaphragm Cover	Gray Iron	Gray Iron	304 SS
Slinger	Nitrile Rubber	Nitrile Rubber	Nitrile Rubber
Lead Wire (or Cable)	XLPE*	XLPE*	XLPE*
Lead Potting	Epoxy	Epoxy	Epoxy
Lead Screws / Clamp	316 SS	316 SS	316 SS
Filter	Delrin & Polyester	Delrin & Polyester	Delrin & Polyester

Component	Construction Type	
	Chemical (316 STNLS)	Oil Stripper
Top Casting	316 SS	316 SS
Bottom Casting	316 SS	316 SS
Stator Shell	316 SS	316 SS
Stator Ends	316 SS	316 SS
Shaft Extension	17-4 SS	17-4 SS
Fasteners	316 SS	316 SS
Seal Cover	316 SS	316 SS
Seal	Sand Fighter SiC Mech Seal	Sand Fighter Viton®
Diaphragm	Nitrile Rubber	Viton®
Diaphragm Cup	316 SS	316 SS
Diaphragm Spring	316 SS	316 SS
Diaphragm Cover	316 SS	316 SS
Slinger	Nitrile Rubber	Viton®
Lead Wire (or Cable)	XLPE*	XLPE*
Lead Potting	Epoxy	Epoxy
Lead Screws / Clamp	316 SS	316 SS
Filter	316 SS Plug	316 SS Plug

* Removable type, factory-installed in 60 Hz and dual frequency rated water well motors. Consult catalog for additional leads.

Specifications subject to change without notice. Contact Franklin Electric if current material types are required for bid specifications.

Viton® is a registered trademark of DuPont Dow Elastomers.

Motors, Drives, Controls & Protection

4" Submersible Motors - Leads & Cabels

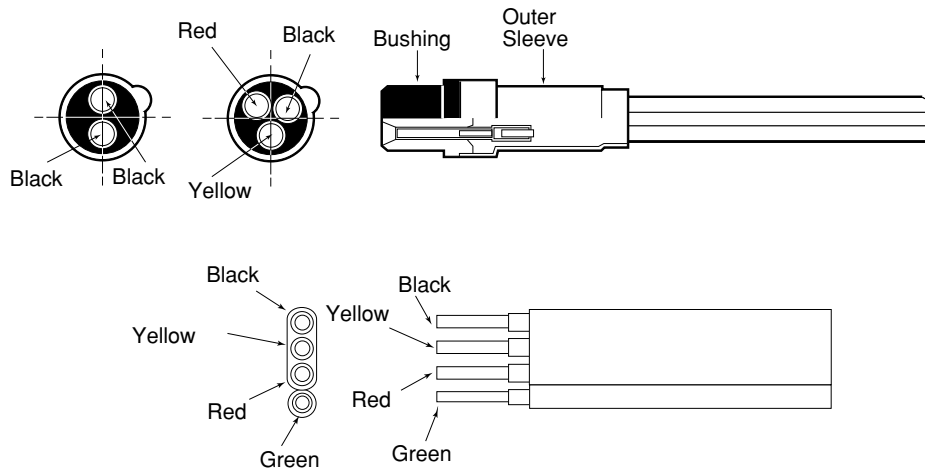

Wire	Construction	Material	Lead Length		Wire Size	Grounded	Jam Nut Model	Clamp Style Model
			IN / FT	M				
2W	Individual	Nitrile*	48 in	1.2	AWG 14	No	152 328 905	N/A
	Individual	Nitrile*	100 in	2.5	AWG 14	No	152 328 906	N/A
	Individual	XLPE	48 in	1.2	AWG 14	Yes	152 552 905	N/A
	Individual	XLPE	100 in	2.5	AWG 14	Yes	152 552 906	N/A
3W	Individual	XLPE	48 in	1.2	AWG 14	Yes	152 553 905	152 735 911
	Individual	XLPE	100 in	2.5	AWG 14	Yes	152 553 906	152 735 941
	Individual	Nitrile*	48 in	1.2	AWG 14	No	152 255 901	N/A
	Individual	Nitrile*	100 in	2.5	AWG 14	No	152 255 902	152 744 902
	Individual	Nitrile*	160 in	4.0	AWG 14	No	152 255 904	152 744 904
	Individual	Nitrile*	30 ft	9.1	AWG 14	No	152 255 906	152 744 906
	Individual	Nitrile*	50 ft	15.2	AWG 14	No	152 255 907	152 744 907
	Individual	Nitrile*	100 ft	30.5	AWG 14	No	152 255 910	152 744 910
	Individual	Nitrile*	150 ft	45.7	AWG 14	No	152 255 912	N/A
	Individual / Dbl Conn	XLPE	48 in	1.2	AWG 14	Yes	152 570 901	N/A
	Individual / Dbl Conn	XLPE	100 in	2.5	AWG 14	Yes	152 570 902	N/A

* Nitrile material not for use in potable water.

Notes:

1. Refer to Franklin Application Installation Maintenance (AIM) manual for accurate cable sizing.
2. MOTOR WARRANTY IS VOID if Franklin-supplied leads are not used.

Submersible Motor Protection - Pumptec Family

Pumptec Single-Phase Protection Devices

Applications

These protection devices are designed to protect Franklin Electric single-phase motors from the various conditions listed below.



QD Pumptec is designed to easily plug into any Franklin QD Relay Control Box.

	QD Pumptec	Pumptec	Pumptec-Plus
Air or Gas Locked Pump (Cavitation)	■	■	■
Broken Shaft or Coupling	■	■	■
Clogged Well Screen	■	■	■
Drop in Water Level	■	■	■
Faulty Check Valve		■	■
High Voltage	■	■	■
Low Voltage	■	■	■
Low Yield Wells	■	■	■
Rapid Cycling		■	■
Water Logged Tank		■	■
Worn Pump Parts	■	■	■

QD Pumptec

Exclusively designed for Franklin QD Relay Control Boxes, QD Pumptec is a solid state sensing device that monitors motor load and incoming power to automatically shut off a Franklin single-phase, 3-wire motor when related fault conditions are detected. QD Pumptec easily plugs into 3-wire Franklin QD Control Boxes with no additional wiring or tools required.

Pumptec

Pumptec is a microcomputer-based device that monitors motor load and power line conditions to provide protection against dry well conditions, waterlogged tanks, and abnormal line voltage conditions. Pumptec interrupts power to the motor whenever the load drops quickly or below a preset level. Indicator lights provide complete system status.

Pumptec-Plus

The Pumptec-Plus solid state pump protection system is designed for 1/2 to 5 hp single-phase submersible pump motors. Pumptec-Plus protects against a variety of fault conditions. Run and fault lights make diagnosis quick and easy. Push button Snap Shot™ calibration makes Pumptec-Plus simple to install and an effective troubleshooting tool.

Motors, Drives, Controls & Protection

Submersible Motor Protection - Pumptec Family

Single-Phase Electronic Protection Device Specifications

Product	HP Range	KW Range	Volts	HZ	Reset Time	Agency Approvals
Pumptec w/IR Control	1/3 - 1.5	0.25 - 1.1	115/230	60/50	Adjustable (2-120 Minutes)	UL/cUL Listed
Pumptec-Plus	1/2 - 5.0	0.37 - 3.7	230	60	Adjustable (1-240 Minutes or Manual)	UL/cUL Listed
Pumptec-Plus	1/2 - 5.0	0.37 - 3.7	220	50	Adjustable (1-240 Minutes or Manual)	UL/cUL Listed
QD Pumptec	1/3 - 1.0	0.25 - 0.75	230	60	Adjustable (2-240 Minutes)	UL/cUL Listed

Models

Product	Description				Model	Stock Status
	PH	HP	Volts	HZ		
Pumptec w/IR Control	1	1/3 - 1.5	115/230	60/50	580 002 0600	Yes
Pumptec-Plus	1	1/2 - 5.0	230	60	580 006 0100	Yes
	1	1/2 - 5.0	220	50	580 006 0500	Yes
QD Pumptec	1	1/3 - 1.0	230	60	580 007 0600	Yes

Single-Phase Protection Devices

Product	Shipping Weight		Motor Carton Size (in inches)
	LBS	KG	
Pumptec w/IR Control	3	1.3	5.25 x 8.875 x 3.25
Pumptec-Plus	7	3.1	8.25 x 11.25 x 6.25
QD Pumptec	<1	<0.05	4.25 x 2.375 x 2.25

QD Pumptec

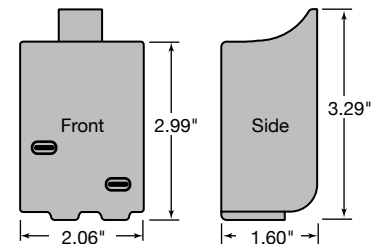

Pumptec IR

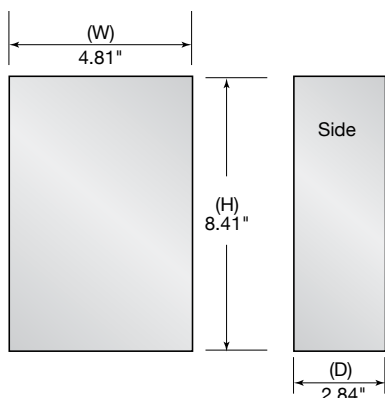

Pumptec-Plus

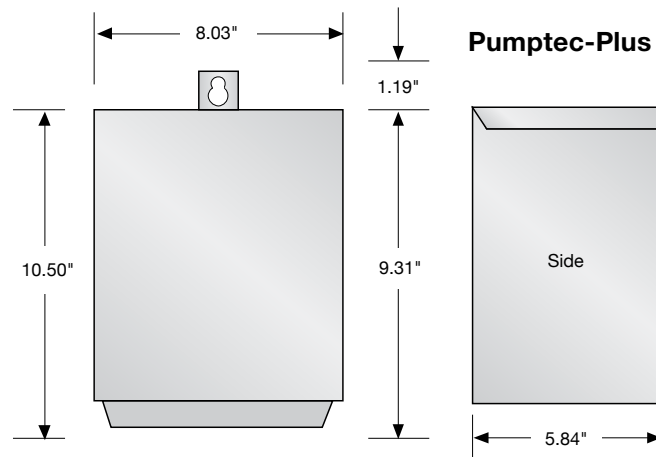

Constant Pressure Drives - SubDrive/MonoDrive



Applications:

Franklin Electric's constant pressure controllers use state-of-the-art technology to provide constant water pressure through variable speed control of submersible water well pumps.

Features — All Controllers:

- Constant water pressure with a wide range of settings (25 to 80 psi)
- NEMA 3R (Outdoor), NEMA 4 (Outdoor) and NEMA 1 (indoor) and NEMA 0 enclosures
- Easy installation
- Soft start feature prevents water hammer and increases motor life
- Works with small pressure tanks or existing larger tanks
- Smart Reset® technology allows well recovery before restarting the pump
- Single-phase input power with three-phase motor performance (SubDrive models)
- Excellent radio frequency interference shielding
- UL and cUL listed
- Built-in diagnostics and protection
 - Surge protection
 - Underload
 - Undervoltage
 - Locked pump
 - Open circuit
 - Short circuit
 - Overheated controller

Motors, Drives, Controls & Protection

Constant Pressure Drives - SubDrive/MonoDrive

Features — MonoDrive & MonoDriveXT:

- Selectable hp rating: MonoDrive (½, ¾ and 1 hp), MonoDriveXT (1.5 and 2 hp)
- Easy installation – remove the 3-wire control box and install the MonoDrive
- Can retrofit existing systems – no need to pull the pump
- NEMA 4 & NEMA 1 enclosure
- Single-phase, 3-wire Franklin Electric motor

Features — SubDrive2W:

- Selectable hp rating: (½, ¾ and 1 hp)
- Easy retrofit installation – remove the pressure switch and install the SubDrive2W
- Can retrofit existing systems – no need to pull the pump or motor
- NEMA 3R enclosure
- Single-phase, 2-wire Franklin Electric motor

Constant Pressure Controls Specifications

		MonoDrive	MonoDriveXT
Model No. (Enclosure*)	(N1)	587 020 3110	587 020 4110
	(N4)	587 020 3114	587 020 4114

Input (From Power Source)

Voltage	190-260 V 1-phase	190-260 V 1-phase
Frequency	60/50 Hz	60/50 Hz
Max Amps (RMS)	5.7 A (½ hp), 8.7 A (¾ hp), 11 A (1 hp)	13 A (1.5 hp), 16 A (2 hp)
Power Factor	1 (Constant)	1 (Constant)

Output (To Motor)

Voltage	Variable/1-phase	Variable/1-phase
Frequency	Variable (30-60 Hz)	Variable (30-60 Hz)
Max Amps (RMS)	4.0 A (½ hp), 6.6 A (¾ hp), 9.0 A (1 hp)	10 A (1.5 hp), 12 A (2 hp)

For Use With

Pump Rating	½, ¾ or 1 hp (Selectable)	1.5 or 2 hp (Selectable)
Motor Rating	½, ¾ or 1 hp, 230 VAC (1-phase)	1.5 or 2 hp, 230 VAC (1-phase)
Pressure Sensor (Included)	External	External
Controller Weight	(N1)	15 lbs (7 kg)
	(N4)	24 lbs (11 kg)
Carton Size (H x W x D)	(N1)	16½ x 12¾ x 9" 41.9 x 31.4 x 22.9 cm
	(N4)	17½ x 16¾ x 11¾" 44.5 x 41.6 x 28.9 cm
Shipping Weight	(N1)	19 lbs (9 kg)
	(N4)	30 lbs (14 kg)

*N1 = NEMA 1 (Indoors), N4 = NEMA 4 (Outdoors), N3R = NEMA 3R (Outdoors)

		SubDrive2W
Model No. (Enclosure*)	(N3R)	587 020 3223

Input (From Power Source)

Voltage	230 V (+/- 10%) 1-phase
Frequency	60/50 Hz
Max Amps (RMS)	<14A
Power Factor	N/A

Output (To Motor)

Voltage	Variable/1-phase/FE Motor
Frequency	Variable (30-60 Hz)
Max Amps (RMS)	6.0 A (½ hp), 8.0 A (¾ hp), 9.8 A (1 hp)

For Use With

Pump Rating	½, ¾ or 1 hp (Selectable)
Motor Rating	½, ¾ or 1 hp, 230 VAC (1-phase), 60 Hz
Pressure Sensor (Included)	External
Controller Weight	15 lbs (7 kg)
Carton Size (H x W x D)	12¼ x 16½ x 9" 31.1 x 41.9 x 22.9 cm
Shipping Weight	18 lbs (8 kg)

Motors, Drives, Controls & Protection

Constant Pressure Drives - SubDrive/MonoDrive

Features — SubDrive75, SubDrive100, SubDrive150 & SubDrive300:

- Works with a standard three-phase Franklin Electric submersible motor
- NEMA 4 & NEMA 1 enclosure
- Three-phase performance with single-phase input
 - High starting torque
 - More efficient
 - Smooth running

Constant Pressure Controls Specifications

		SubDrive75	SubDrive100	SubDrive150	SubDrive300
Model No.	(N1)	587 020 3380	587 020 4100	587 020 4150	N/A
(Enclosure*)	(N4)	587 020 3384	587 020 4104	587 020 4154	587 020 6300

Input (From Power Source)

Voltage	190-260 V 1-Phase	190-260 V 1-Phase	190-260 V 1-Phase	220-260 V 1-Phase
Frequency	60/50 Hz	60/50 Hz	60/50 Hz	60/50 Hz
Max Amps (RMS)	11 A	19 A	23 A	36 A
Power Factor	1 (Constant)	1 (Constant)	1 (Constant)	1 (Constant)

Output (To Motor)

Voltage	Variable/3-Phase	Variable/3-Phase	Variable/3-Phase	Variable/3-Phase
Frequency	Variable (30-80 Hz)	Variable (30-80 Hz)	Variable (30-80 Hz)	Variable (30-80 Hz)
Max Amps (RMS)	5.9 A	8.1 A	10.9 A	17.8 A

For Use With

Pump Rating		¾, 1 or 1.5 hp (Selectable)	1, 1.5 or 2 hp (Selectable)	1.5, 2 or 3 hp (Selectable)	3 or 5 hp (Selectable)
Motor Rating		1.5 hp, 230 VAC (3-Phase)	2 hp, 230 VAC (3-Phase)	3 hp, 230 VAC (3-Phase)	5 hp, 230 VAC (3-Phase)
Pressure Sensor (Included)		External	External	External	External
Controller Weight	(N1)	15 lbs (7 kg)	18 lbs (8 kg)	18 lbs (8 kg)	N/A
	(N4)	24 lbs (11 kg)	28 lbs (13 kg)	28 lbs (13 kg)	35 lbs (16 kg)
Carton Size (H x W x D)	(N1)	16½ x 12¾ x 9" 41.9 x 31.4 x 22.9 cm	16½ x 12¾ x 9" 41.9 x 31.4 x 22.9 cm	16½ x 12¾ x 9" 41.9 x 31.4 x 22.9 cm	N/A
	(N4)	17½ x 16¾ x 11¾" 44.5 x 41.6 x 28.9 cm	17½ x 16¾ x 11¾" 44.5 x 41.6 x 28.9 cm	17½ x 16¾ x 11¾" 44.5 x 41.6 x 28.9 cm	19¾ x 17½ x 14¼" 50.5 x 44.5 x 36.2 cm
Shipping Weight	(N1)	19 lbs (9 kg)	21 lbs (10 kg)	21 lbs (10 kg)	N/A
	(N4)	31 lbs (14 kg)	35 lbs (16 kg)	35 lbs (16 kg)	41 lbs (19 kg)

*N1 = NEMA 1 (Indoors), N4 = NEMA 4 (Outdoors)

Motors, Drives, Controls & Protection

Constant Pressure Drives - SubDrive/MonoDrive

SubDrive300

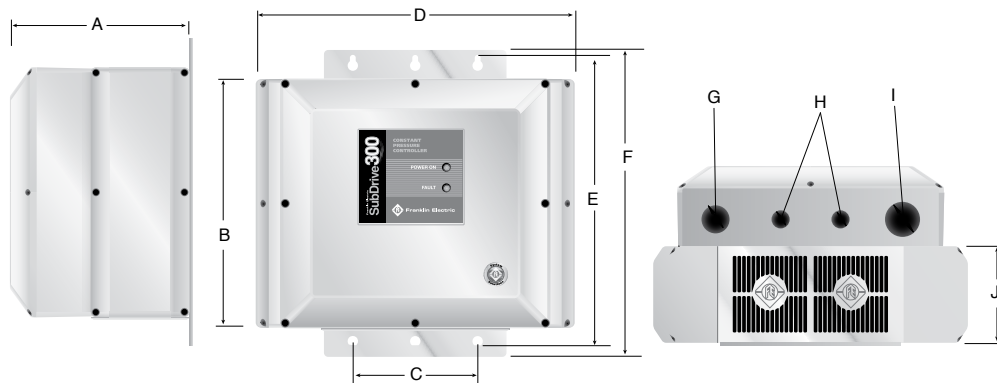

NEMA 4 Dimensions (approximate)

NEMA 4	A	B	C	D	E	F	G	H	I	J
Dimension	8.75" (22.23 cm)	12" (30.48 cm)	6" (15.24 cm)	15.34" (38.96 cm)	14" (35.56 cm)	14.75" (37.47 cm)	1.37" (3.48 cm)	0.885" (2.25 cm)	1.71" (4.34 cm)	4.75" (12.07 cm)
Conduit Size	-	-	-	-	-	-	1	1/2	1/4	-

SubDrive2W

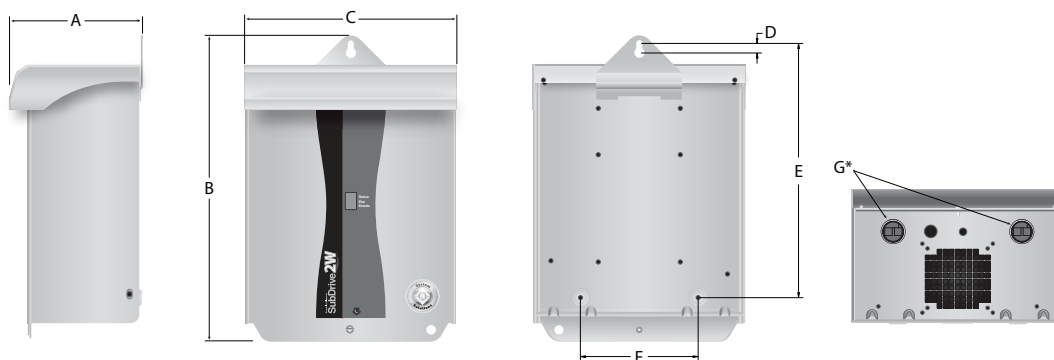

NEMA 3R Dimensions (approximate)

NEMA 3R	A	B	C	D	E	F	G
Dimension	6.20" (15.75 cm)	14.27" (36.25 cm)	9.91" (25.71 cm)	.44" (1.12 cm)	11.87" (30.15 cm)	5.5" (13.97 cm)	.88" / 1.13" (2.24 cm) / (2.87 cm)
Conduit Size	-	-	-	-	-	-	1/2 / 3/4

* Use knock-outs as required.

Motors, Drives, Controls & Protection

Constant Pressure Drives - SubDrive/MonoDrive

SubDrive75/100/150/MonoDrive/MonoDriveXT

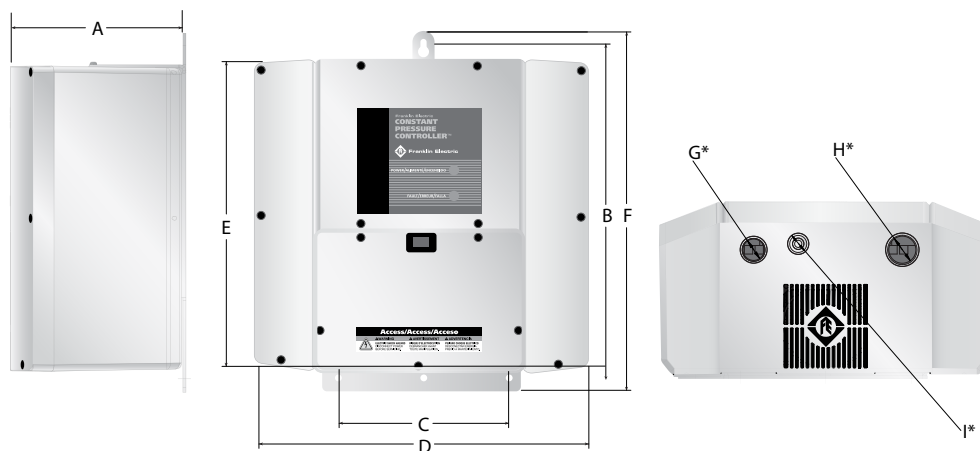

NEMA 4 Dimensions (approximate)

NEMA 4	A	B	C	D	E	F	G	H	I
Dimension	7.25" (18.42 cm)	12.6" (32.0 cm)	7" (17.78 cm)	13.6" (34.5 cm)	12.5" (31.75 cm)	14.8" (37.6 cm)	0.875" / 1.100" (0.22 cm) / (2.80 cm)	1.100" / 1.375" (2.8 cm) / (3.50 cm)	closed / 0.473" / 0.875" closed / (1.20 cm) / (2.22 cm)
Conduit Size	-	-	-	-	-	-	1/2 / 3/4	3/4 / 1	1/2

SubDrive75/100/150/MonoDrive/MonoDriveXT

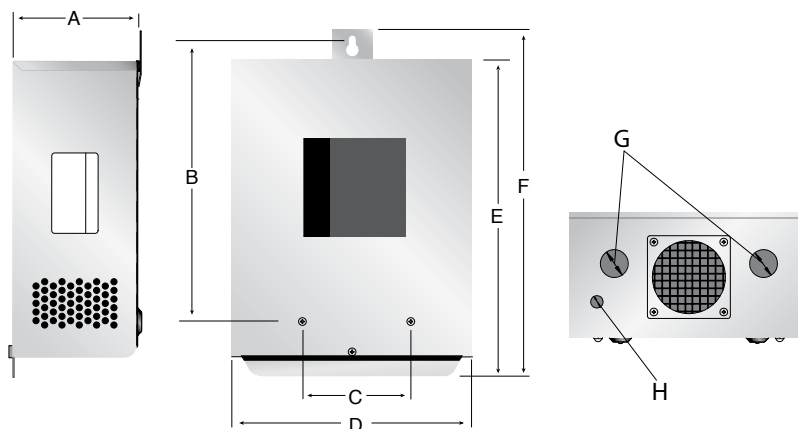

NEMA 1 Dimensions (approximate)

NEMA 1	A	B	C	D	E	F	G	H
Dimension	5.25" (13.34 cm)	11.5" (29.21 cm)	5.5" (13.97 cm)	9.75" (24.77 cm)	12.8" (32.51 cm)	14" (35.56 cm)	1.12" (2.84 cm)	0.5" (1.27 cm)
Conduit Size	-	-	-	-	-	-	3/4	-

* Use knock-outs as required.

Motors, Drives, Controls & Protection

Constant Pressure Drives - SubDrive75 Performance

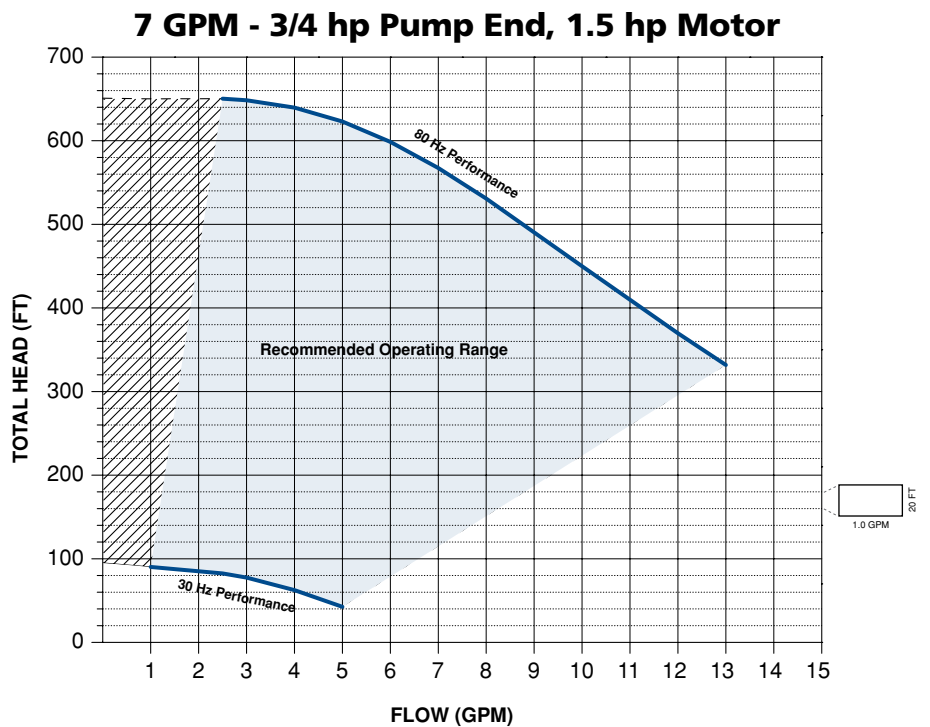
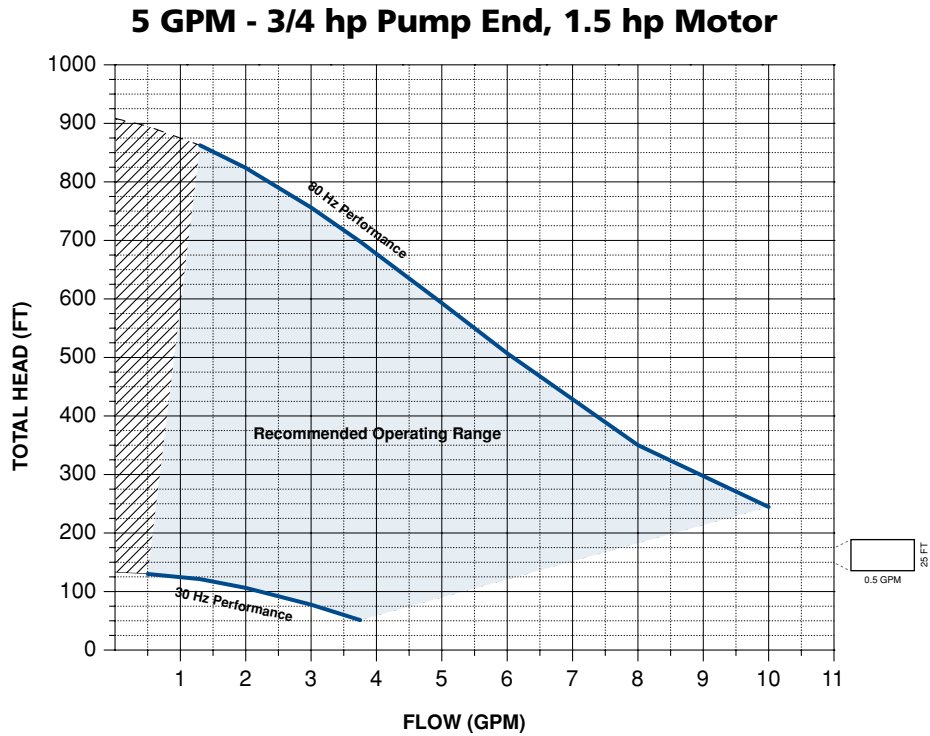

Note: Actual maximum performance of the SubDrive QuickPAK system is power limited by the SubDrive unit. This limit is based on the maximum allowable AMP load of the submersible motor. The result is in some installations an 80 Hz speed may not be attained.

Constant Pressure Drives - SubDrive75 Performance

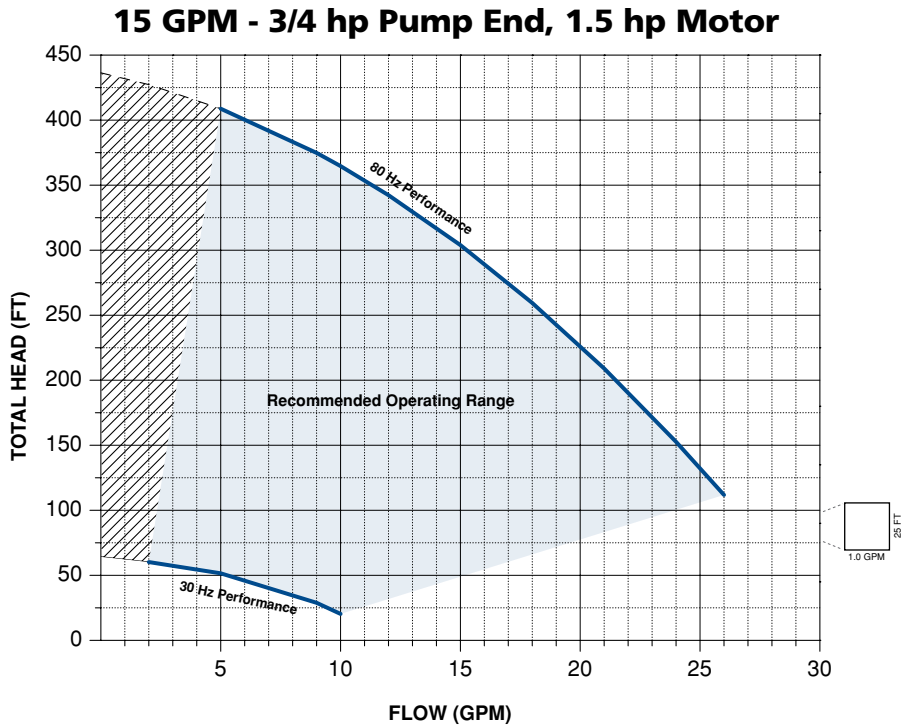
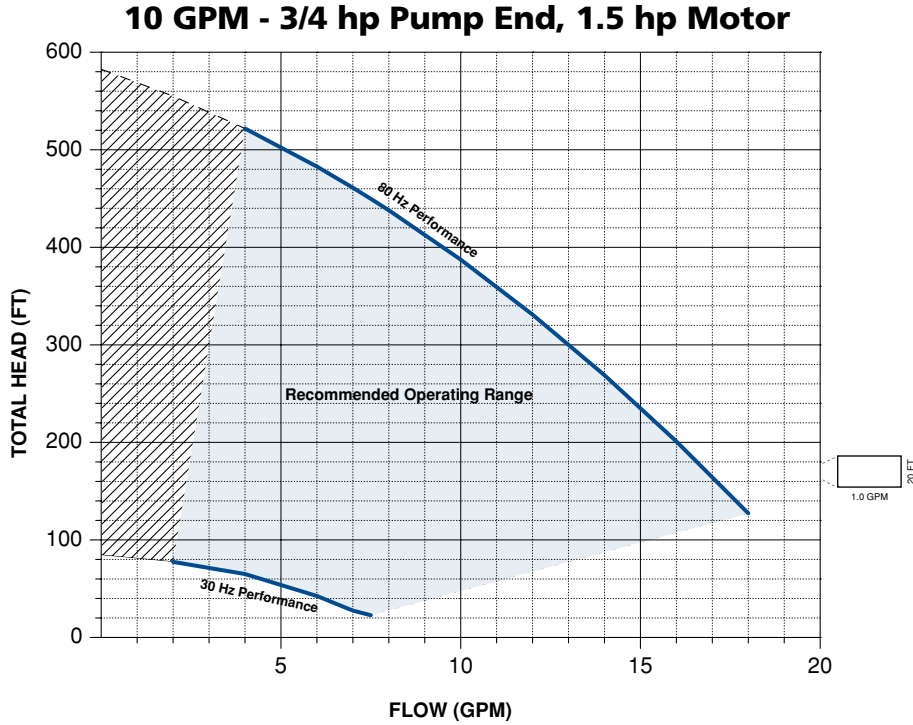

Note: Actual maximum performance of the SubDrive QuickPAK system is power limited by the SubDrive unit. This limit is based on the maximum allowable AMP load of the submersible motor. The result is in some installations an 80 Hz speed may not be attained.

Constant Pressure Drives - SubDrive75 Performance

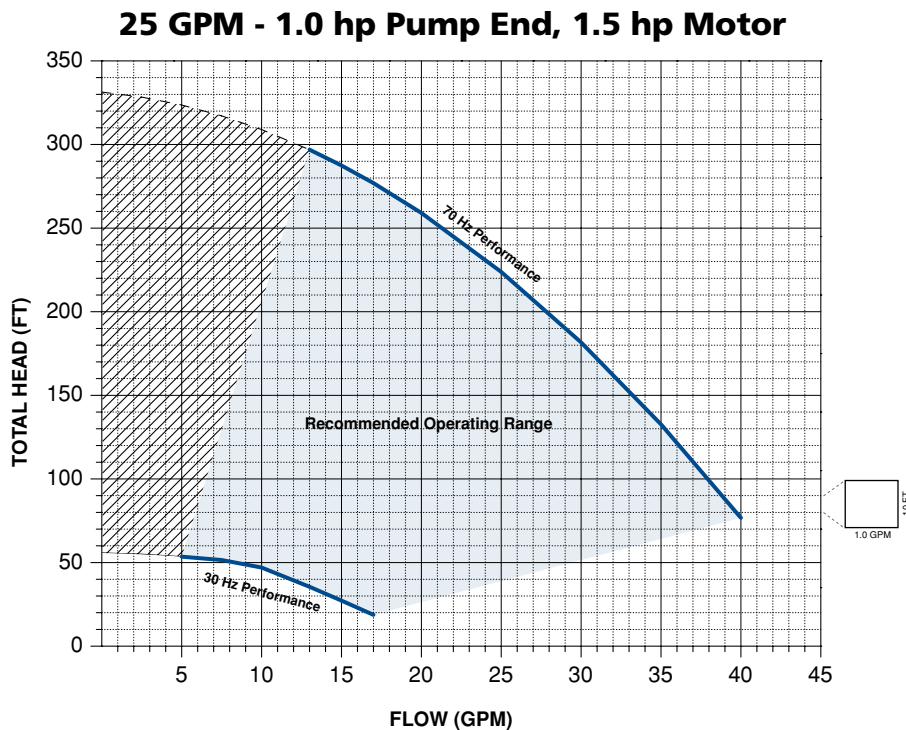
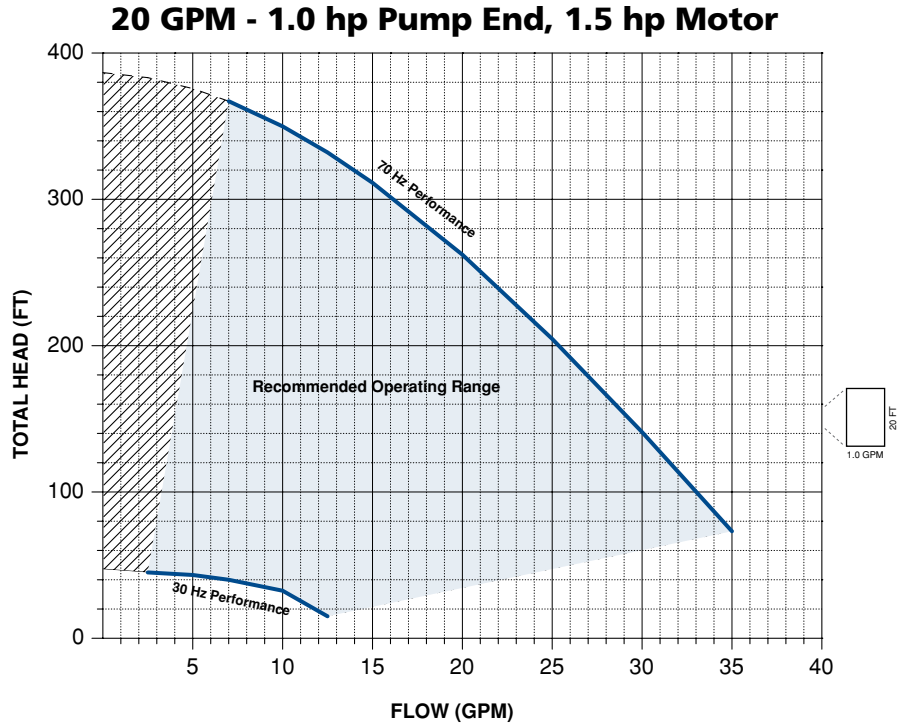

Note: Actual maximum performance of the SubDrive QuickPAK system is power limited by the SubDrive unit. This limit is based on the maximum allowable AMP load of the submersible motor. The result is in some installations an 80 Hz speed may not be attained.

Constant Pressure Drives - SubDrive75 Performance

35 GPM - 1.0 hp Pump End, 1.5 hp Motor

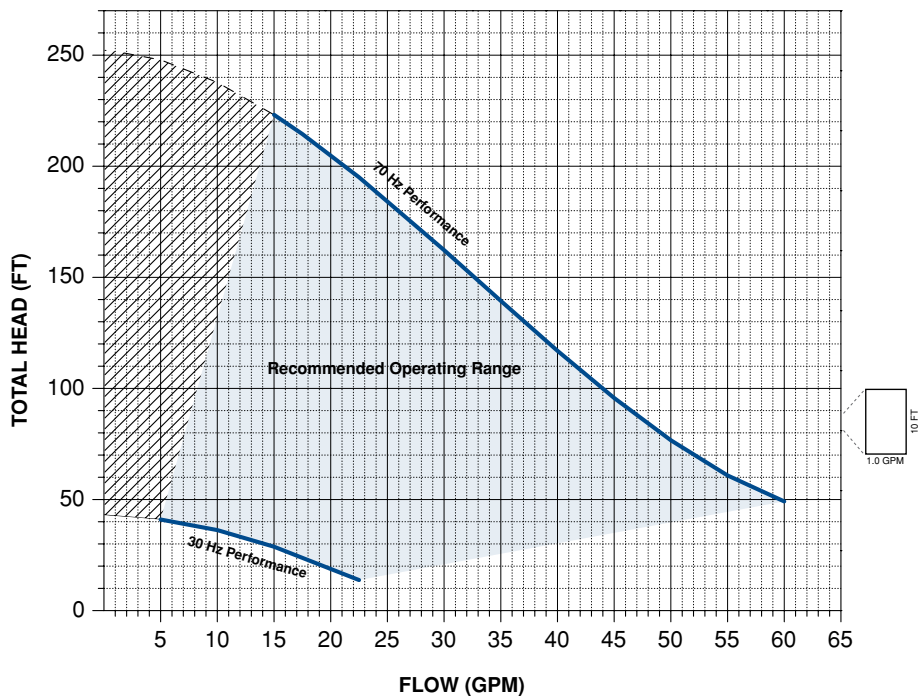

Note: Actual maximum performance of the SubDrive QuickPAK system is power limited by the SubDrive unit. This limit is based on the maximum allowable AMP load of the submersible motor. The result is in some installations an 80 Hz speed may not be attained.

Motors, Drives, Controls & Protection

Constant Pressure Drives - SubDrive100 Performance

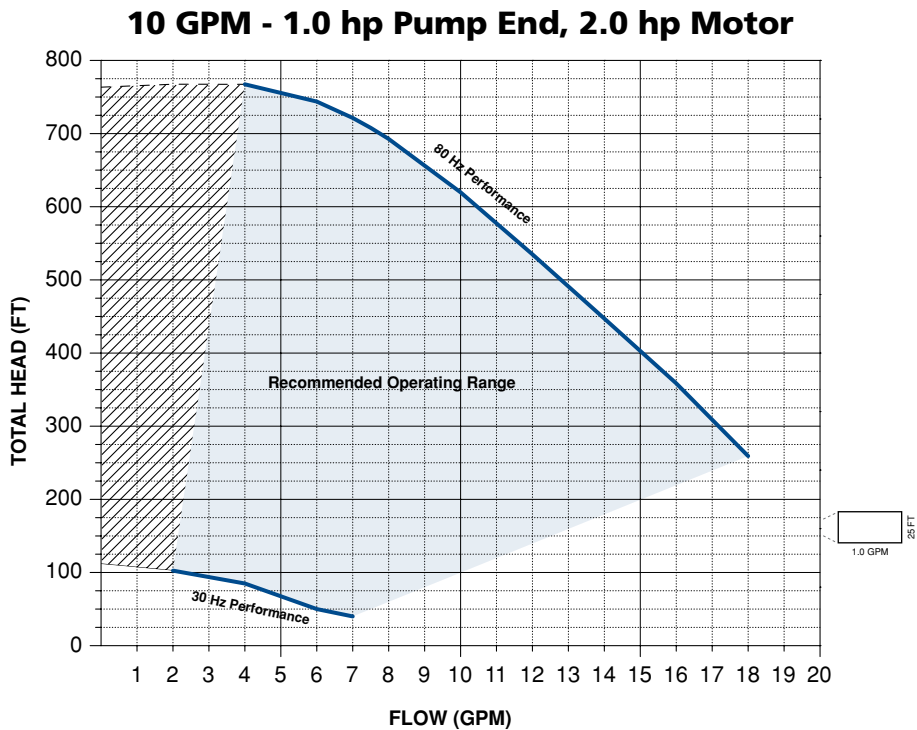
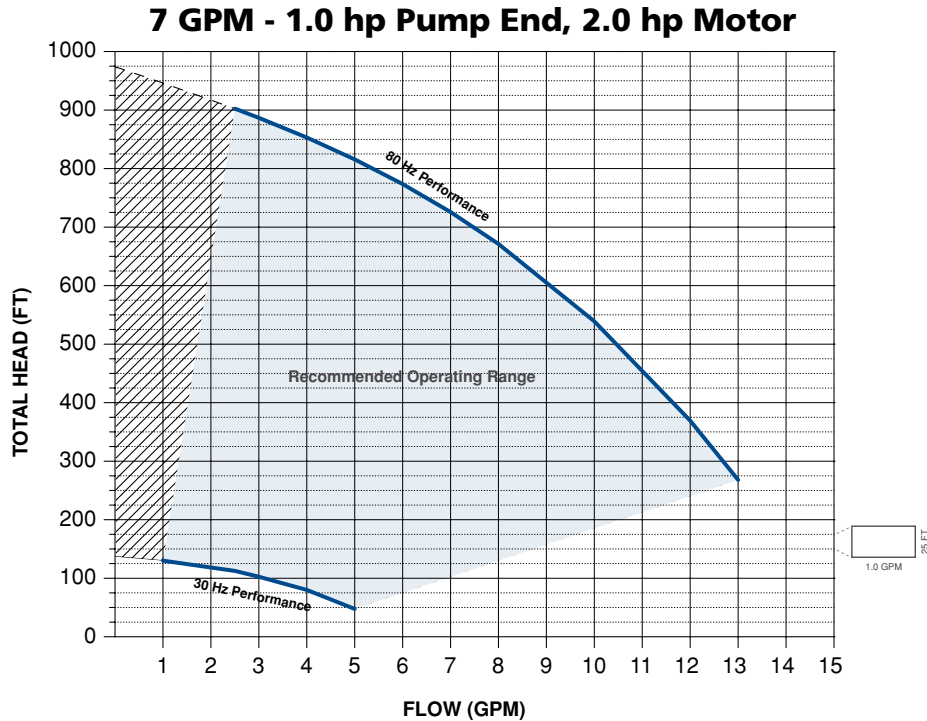

Note: Actual maximum performance of the SubDrive QuickPAK system is power limited by the SubDrive unit. This limit is based on the maximum allowable AMP load of the submersible motor. The result is in some installations an 80 Hz speed may not be attained.

Motors, Drives, Controls & Protection

Constant Pressure Drives - SubDrive100 Performance

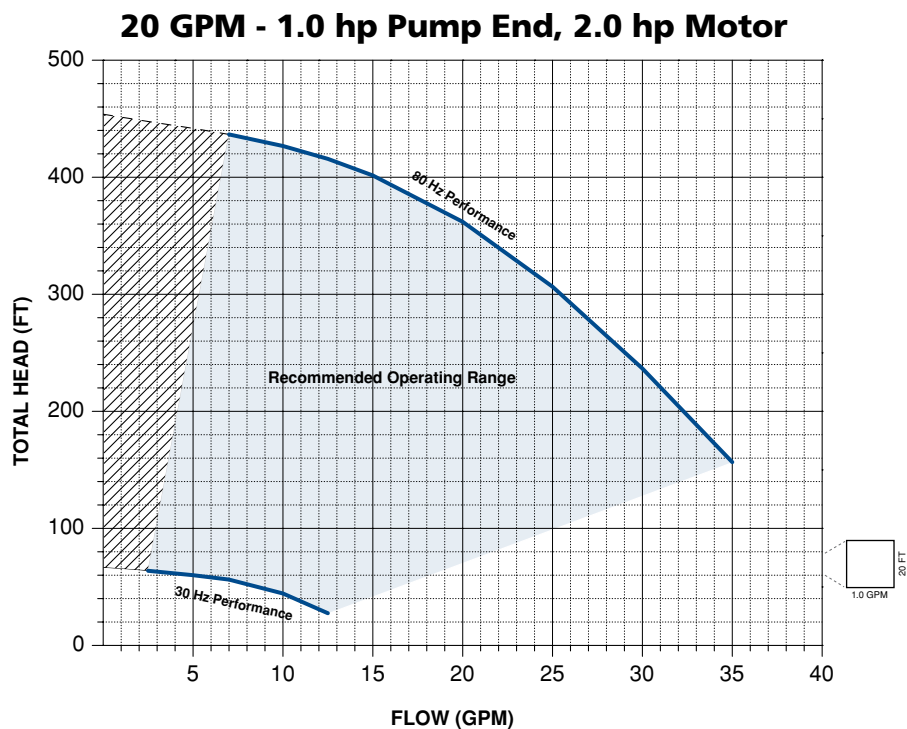
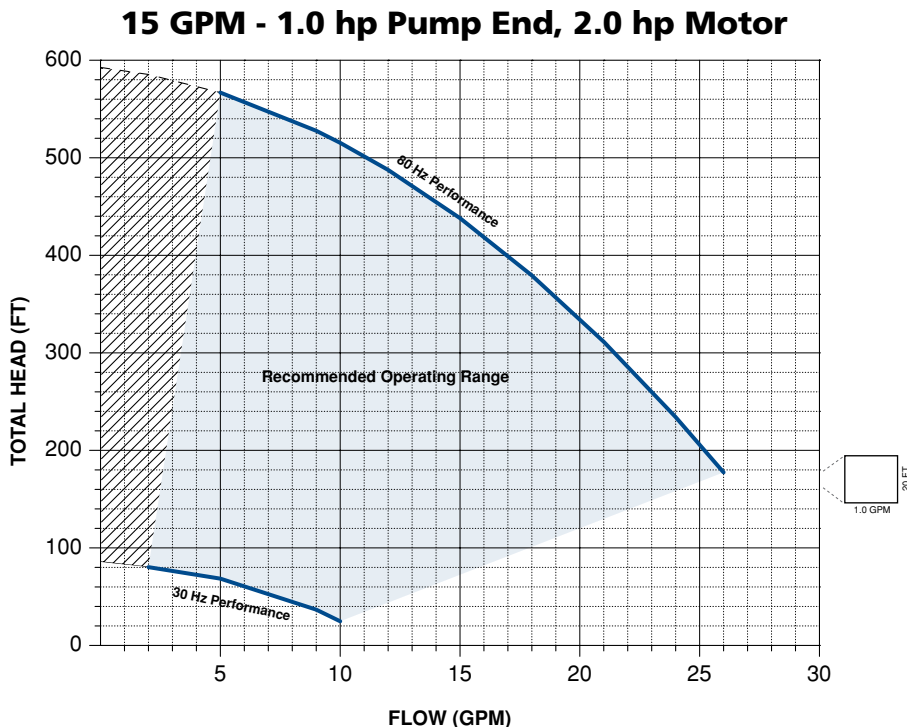

Note: Actual maximum performance of the SubDrive QuickPAK system is power limited by the SubDrive unit. This limit is based on the maximum allowable AMP load of the submersible motor. The result is in some installations an 80 Hz speed may not be attained.

Motors, Drives, Controls & Protection

Constant Pressure Drives - SubDrive100 Performance

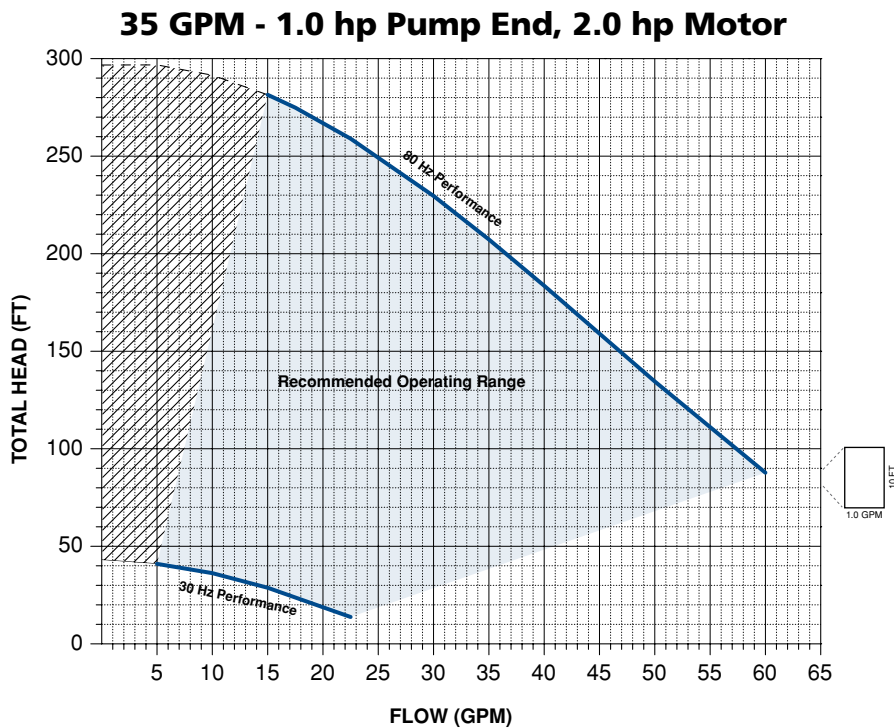
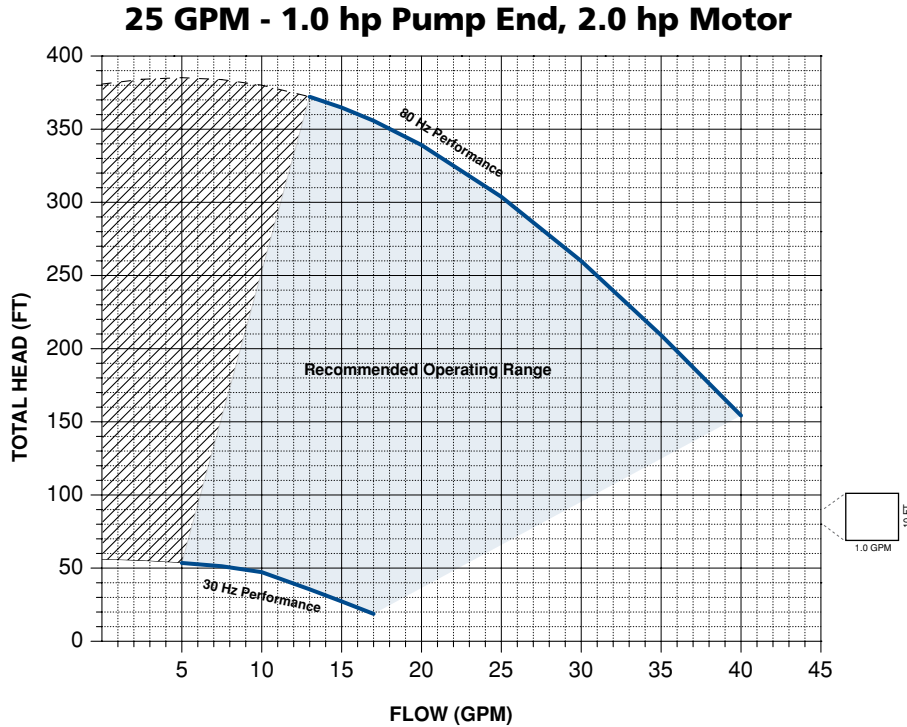

Note: Actual maximum performance of the SubDrive QuickPAK system is power limited by the SubDrive unit. This limit is based on the maximum allowable AMP load of the submersible motor. The result is in some installations an 80 Hz speed may not be attained.

Constant Pressure Drives - SubDrive150 Performance

5 GPM - 1.5 hp Pump End, 3.0 hp Motor

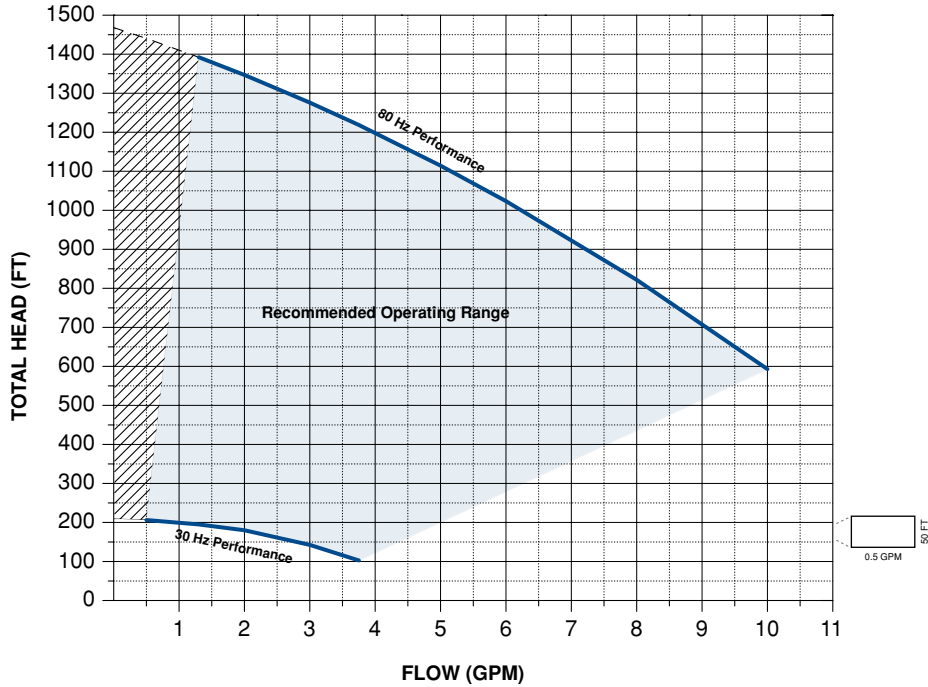

7 GPM - 1.5 hp Pump End, 3.0 hp Motor

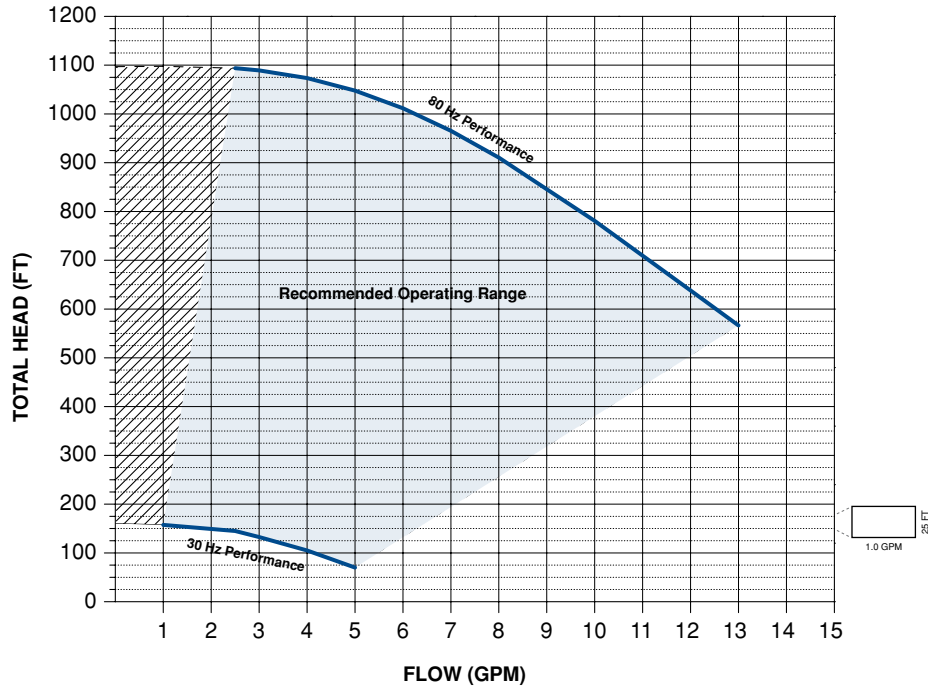

Note: Actual maximum performance of the SubDrive QuickPAK system is power limited by the SubDrive unit. This limit is based on the maximum allowable AMP load of the submersible motor. The result is in some installations an 80 Hz speed may not be attained.

Constant Pressure Drives - SubDrive150 Performance

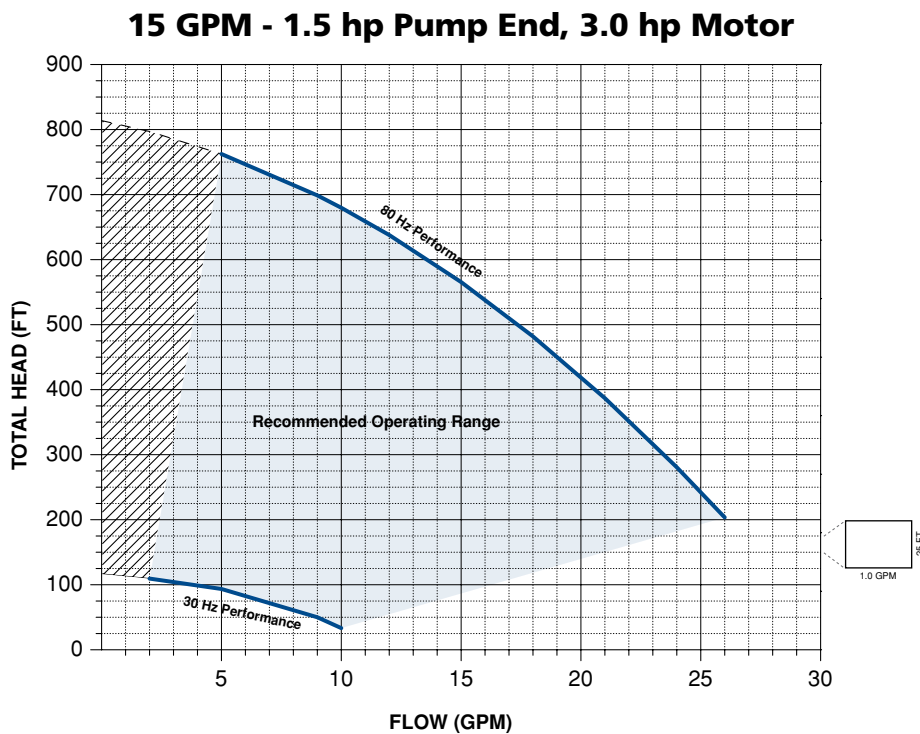
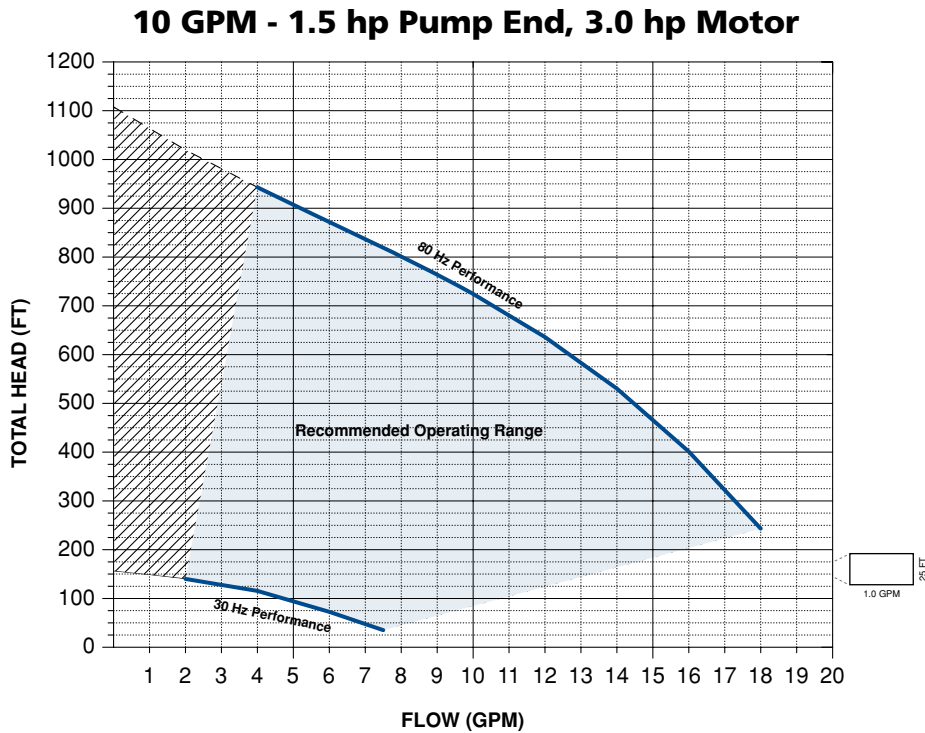

Note: Actual maximum performance of the SubDrive QuickPAK system is power limited by the SubDrive unit. This limit is based on the maximum allowable AMP load of the submersible motor. The result is in some installations an 80 Hz speed may not be attained.

Constant Pressure Drives - SubDrive150 Performance

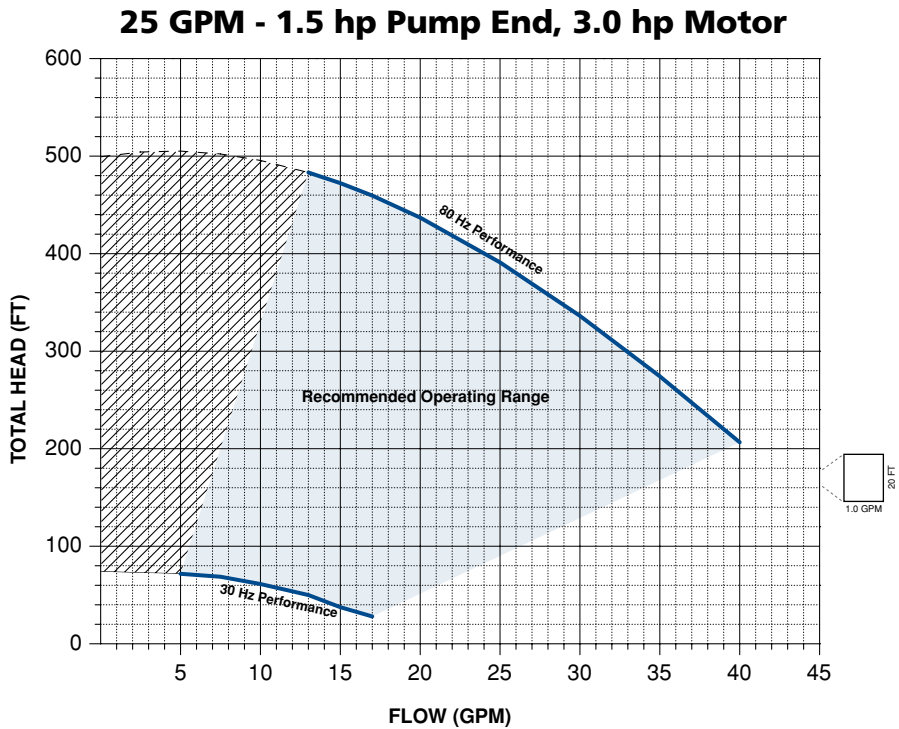
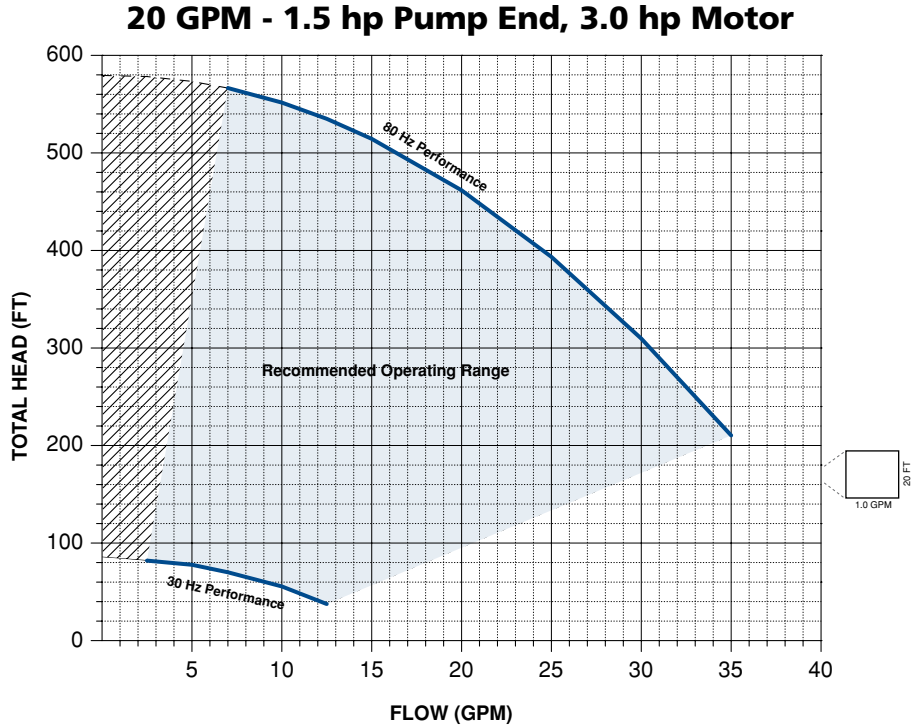

Note: Actual maximum performance of the SubDrive QuickPAK system is power limited by the SubDrive unit. This limit is based on the maximum allowable AMP load of the submersible motor. The result is in some installations an 80 Hz speed may not be attained.

Constant Pressure Drives - SubDrive150 Performance

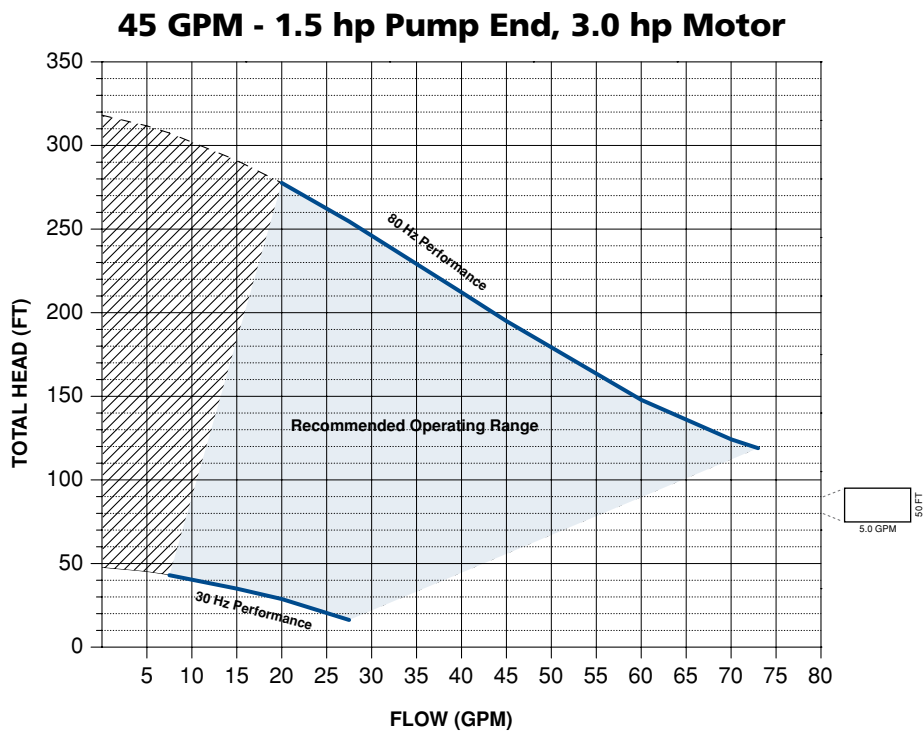
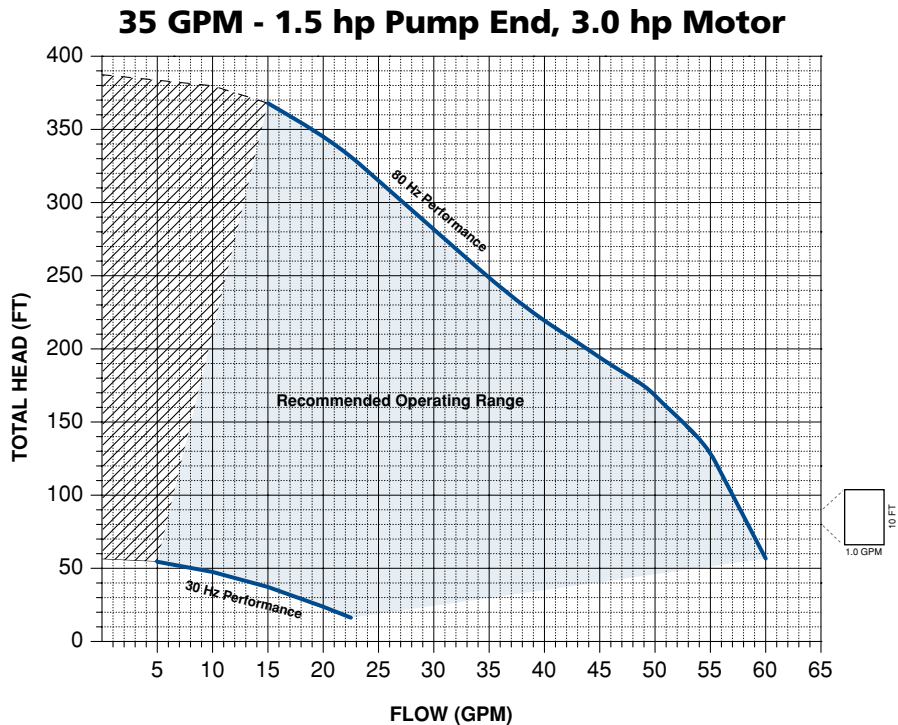

Note: Actual maximum performance of the SubDrive QuickPAK system is power limited by the SubDrive unit. This limit is based on the maximum allowable AMP load of the submersible motor. The result is in some installations an 80 Hz speed may not be attained.

Constant Pressure Drives - SubDrive150 Performance

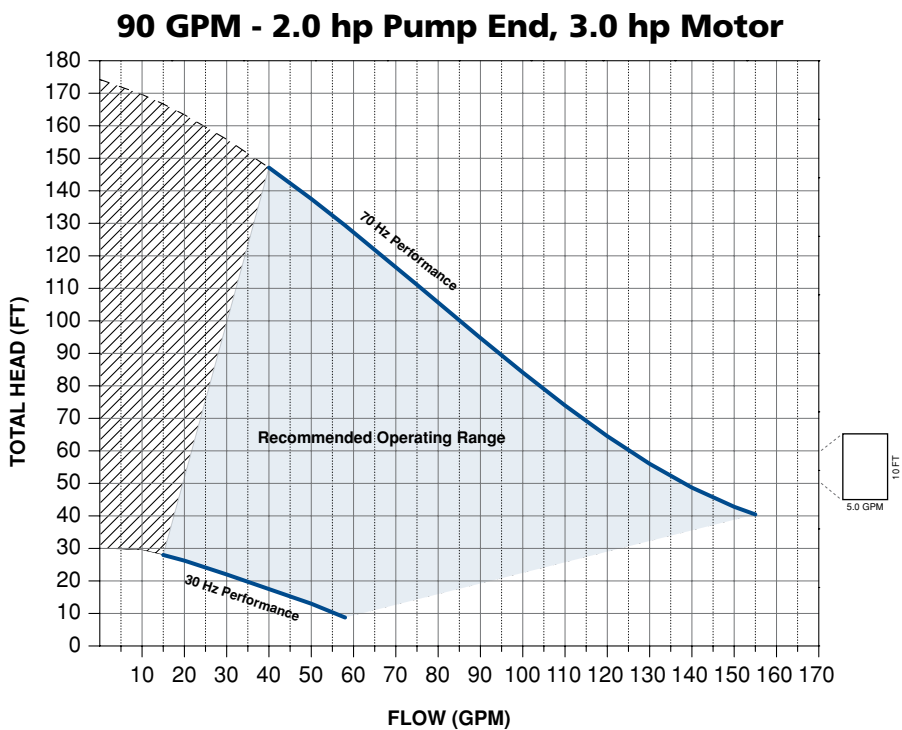
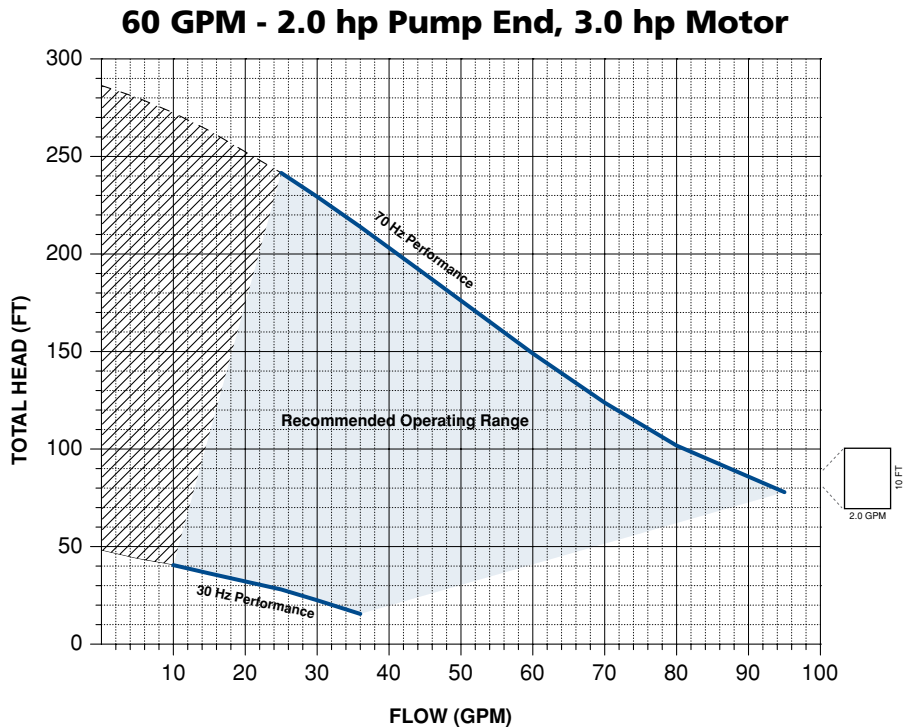

Note: Actual maximum performance of the SubDrive QuickPAK system is power limited by the SubDrive unit. This limit is based on the maximum allowable AMP load of the submersible motor. The result is in some installations an 80 Hz speed may not be attained.

Constant Pressure Drives - SubDrive300 Performance

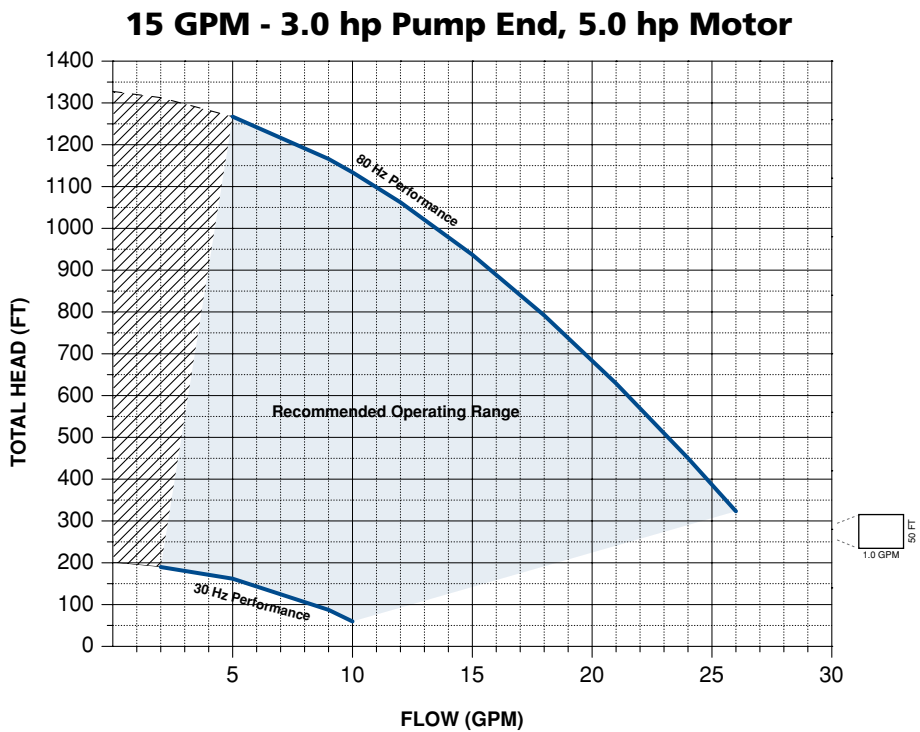
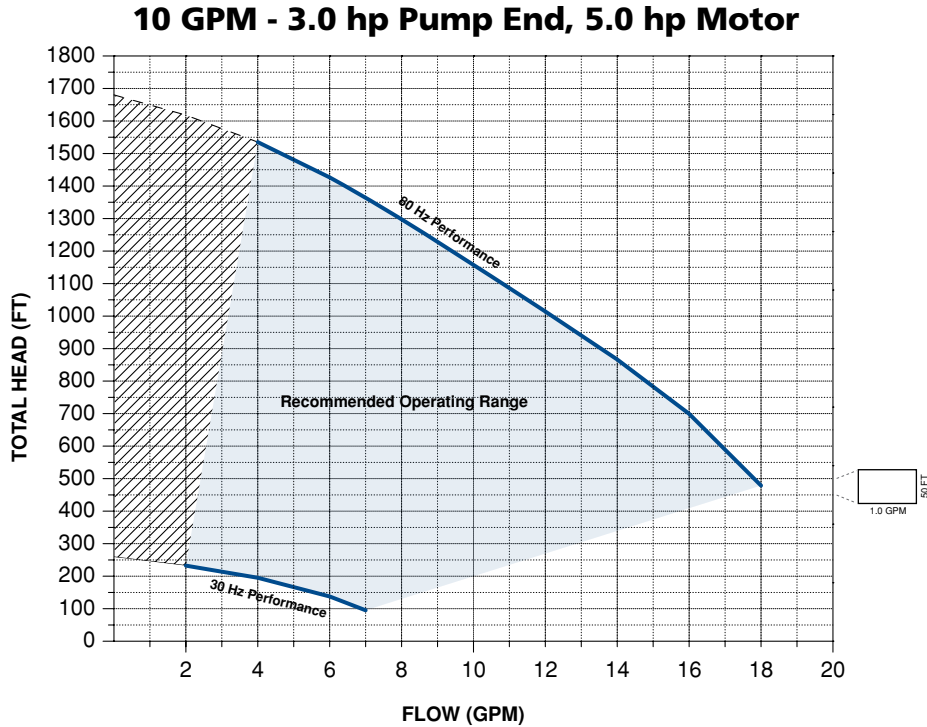

Note: Actual maximum performance of the SubDrive QuickPAK system is power limited by the SubDrive unit. This limit is based on the maximum allowable AMP load of the submersible motor. The result is in some installations an 80 Hz speed may not be attained.

Constant Pressure Drives - SubDrive300 Performance

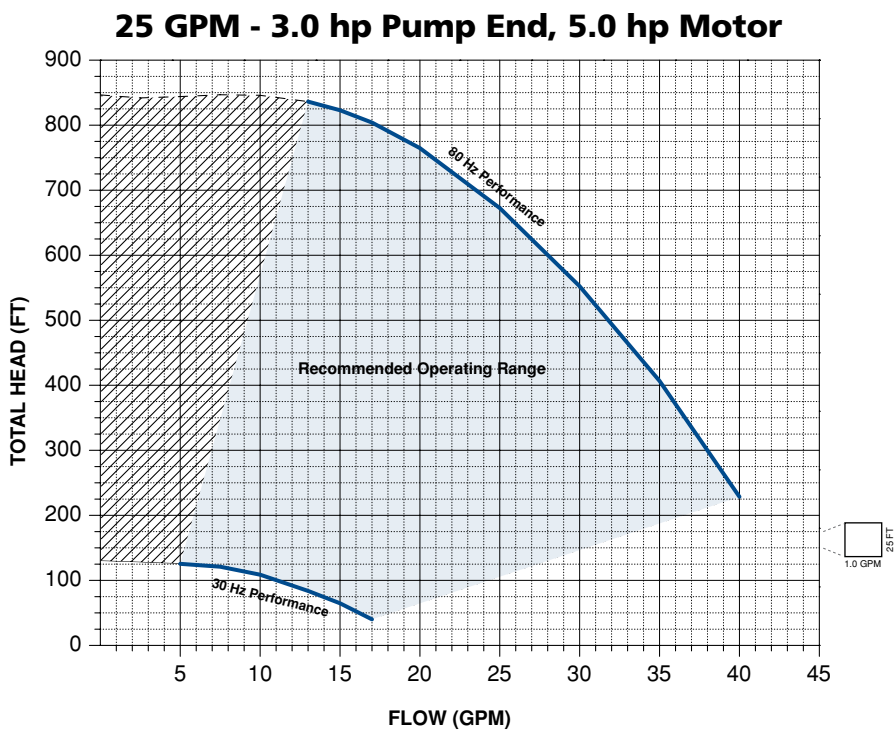
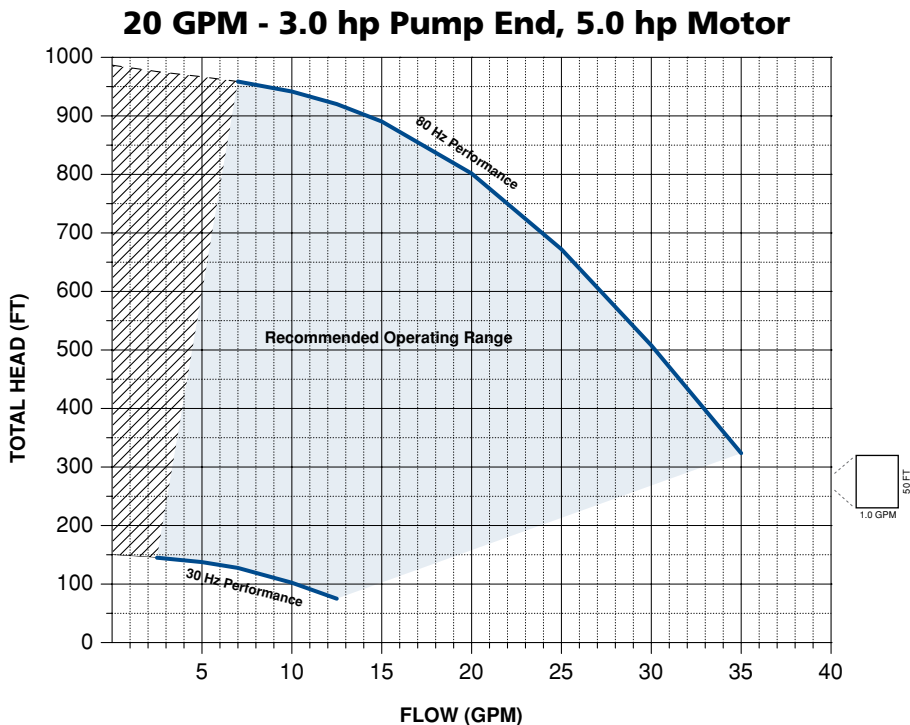

Note: Actual maximum performance of the SubDrive QuickPAK system is power limited by the SubDrive unit. This limit is based on the maximum allowable AMP load of the submersible motor. The result is in some installations an 80 Hz speed may not be attained.

Constant Pressure Drives - SubDrive300 Performance

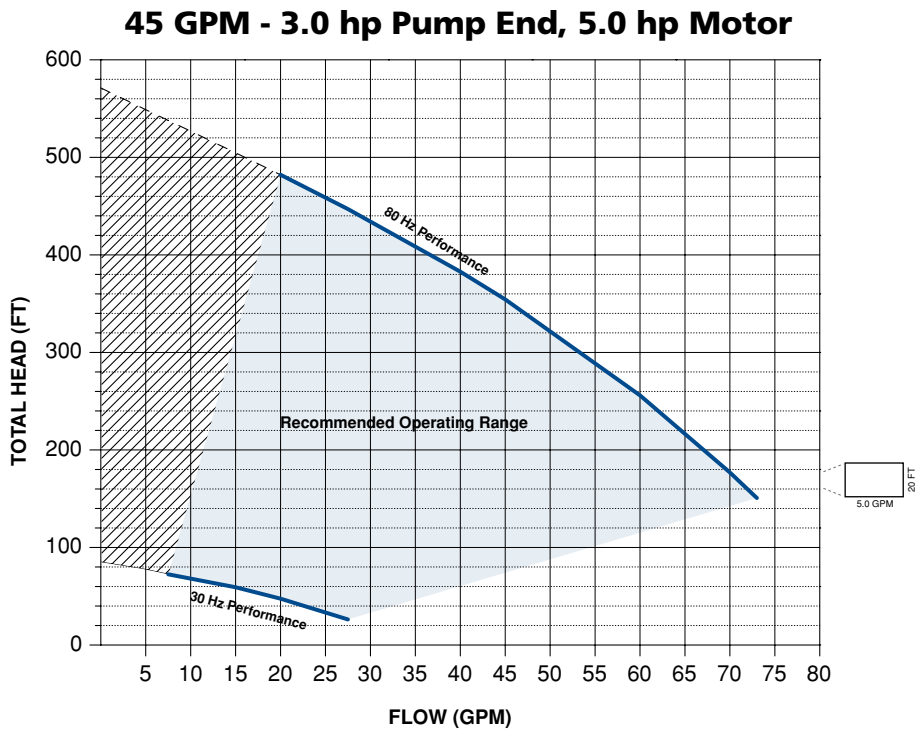
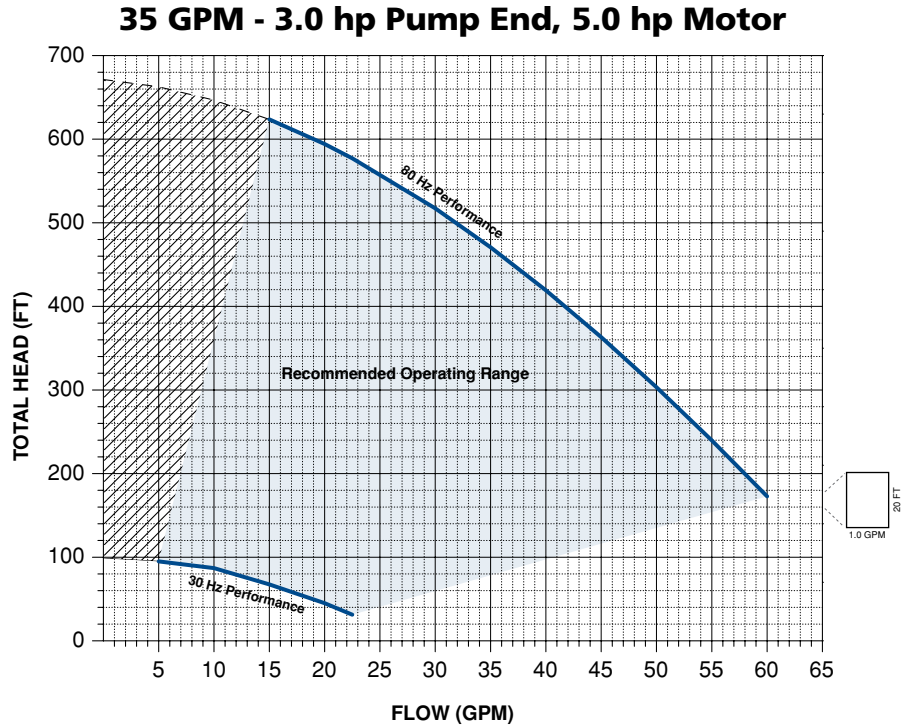

Note: Actual maximum performance of the SubDrive QuickPAK system is power limited by the SubDrive unit. This limit is based on the maximum allowable AMP load of the submersible motor. The result is in some installations an 80 Hz speed may not be attained.

Constant Pressure Drives - SubDrive300 Performance

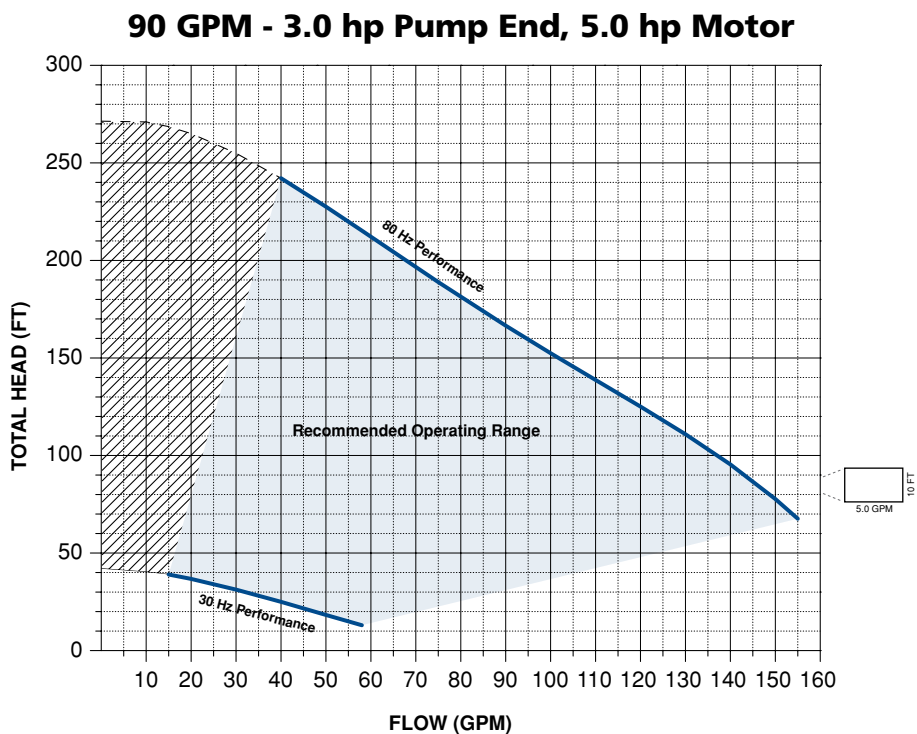
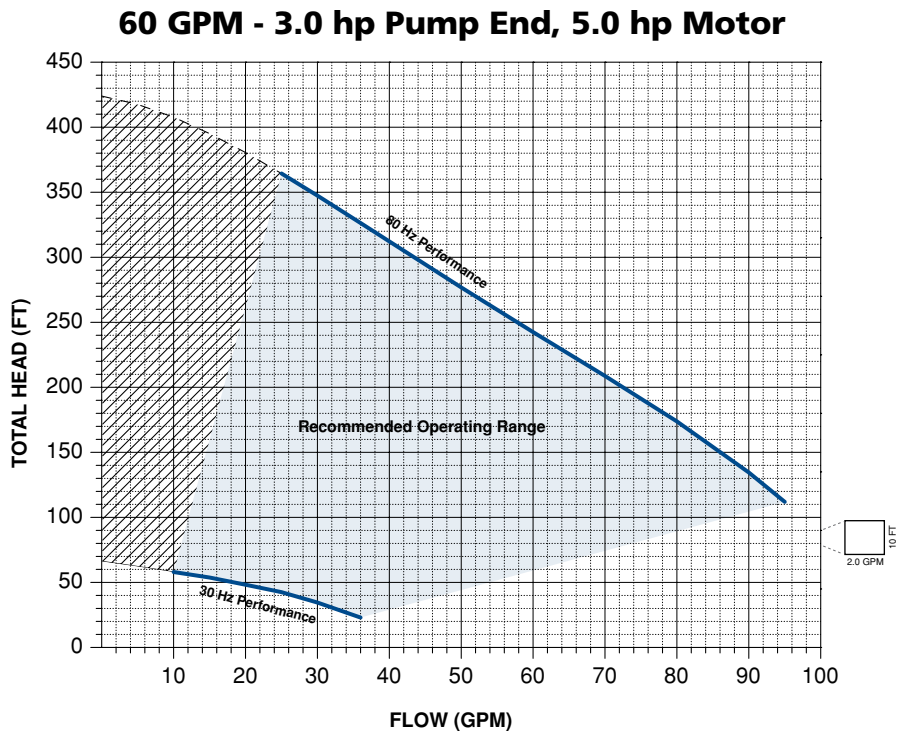

Note: Actual maximum performance of the SubDrive QuickPAK system is power limited by the SubDrive unit. This limit is based on the maximum allowable AMP load of the submersible motor. The result is in some installations an 80 Hz speed may not be attained.

Constant Pressure Controllers - SubDrive Accessories



SubDrive Duplex Alternator

The SubDrive Alternator allows a water system to alternate between two parallel pumps controlled by separate SubDrives or MonoDrives. The user-selected switching interval balances the run time of each pump system to evenly disperse the workload. In addition, when demand exceeds the capacity of one pumping system, the other system comes online to supplement production. The SubDrive Alternator can be used with any SubDrive or MonoDrive controller.

Franklin Part Number: 585 001 2000

Input (From Power Source)	Voltage	115 VAC
	Frequency	60 Hz
Pressure Setting*	Factory Preset	50 psi
	Adjustment Range	25-80 psi
Approximate Controller Size (NEMA 4)	Outer Dimensions	5.8 x 5.8 x 3.6" (14.7 x 14.7 x 9.1 cm)
	Weight	1.3 lbs (0.59 kg)

* Pressure sensors must be set at least 3 psi apart.

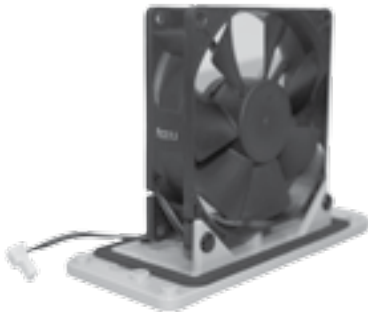

SubDrive/MonoDrive Fan Kits

Installers can remove the fan and make an attempt to clean the fan by removing any particles that may restrict movement. In applications where the fan cannot be cleaned or freed from particles, or is damaged or malfunctioning, the fan replacement kit is an easy and inexpensive fix.

NEMA 4

Controller	Kit Part Number
MonoDrive SubDrive75	225 635 901
MonoDriveXT SubDrive100 SubDrive150	225 635 902
SubDrive300	External cooling fans 225 635 903
	Internal stirring fan 225 635 904

NEMA 1

Controller	Size	Kit Part Number
SubDrive75 and MonoDrive	3.15 in. (80 mm)*	225 635 905
SubDrive75 and MonoDrive	3.62 in. (92 mm)*	225 635 908
SubDrive100/150 and MonoDriveXT	3.15 in. (80 mm)*	225 635 907
SubDrive100/150 and MonoDriveXT	3.62 in. (92 mm)*	225 635 909

* Outside measurement of fan

NEMA 3R

Controller	Kit Part Number
SubDrive2W	225 635 910

Constant Pressure Controllers - SubDrive Accessories

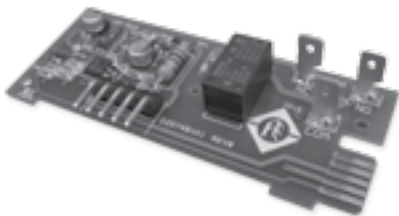

Auxiliary Relay Communications Board

The auxiliary relay communications board is available for use with the SubDrive/MonoDrive NEMA 4 (excluding SubDrive300) constant pressure controllers. The auxiliary relay board provides run-indication relay contacts. The relays can be used to communicate the state of the drive (running or idle) to auxiliary equipment (water treatment) or to utilize multiple sensors (Tank Drawdown Kit).

Franklin Part Number: 225755901

Tank Drawdown Kit

The tank drawdown kit is available for use with the SubDrive/MonoDrive NEMA 4 and the SubDrive300 with an auxiliary relay board installed utilizing the relay contacts. The kit is intended to allow the SubDrive system to utilize water from a tank during low flow applications.

Franklin Part Number: 225770901

Heatsink Cover Kit

The heatsink cover kit is available for use with the SubDrive/MonoDrive NEMA 4 constant pressure controllers. The kit is a grill to protect the top of the unit's heat sink from intrusion from animals or debris when mounted outside.

Franklin Part Number: 225805901

Direct Burial Cable

The direct burial cable kits are for use with the SubDrive/MonoDrive constant pressure controllers as a connection to the pressure sensors. The direct burial cable can be used for applications that require the sensor cable to be buried and extends the allowable length of the pressure sensor connection from 100 ft (30.5 m) to 300 ft (91.5 m).

Description	Franklin Part Number
Direct Burial Kit - 10 ft (3 m)	225800901
Direct Burial Kit - 30 ft (9 m)	225800902
Direct Burial Kit - 100 ft (30.5 m)	225800903

SubDrive2W Air Filter Kit

The Air Filter Kit is available for use with the SubDrive2W NEMA 3R. The kit is designed to allow the SubDrive2W system enclosure to be equipped with air filters that prevent contaminants or debris from entering the electronics.

Franklin Part Number: 225835901

References

Friction Loss

PVC Schedule 80 IPS Plastic Pipe in Feet per 100 feet of pipe

Pipe Size	1/2"		3/4"		1"		1-1/4"		1.5"		2"		2.5"		3"		4"	
	GPM	Head Loss	Vel (ft/s)	Head Loss	Vel (ft/s)	Head Loss	Vel (ft/s)	Head Loss	Vel (ft/s)	Head Loss	Vel (ft/s)	Head Loss	Vel (ft/s)	Head Loss	Vel (ft/s)	Head Loss	Vel (ft/s)	
1	1.87	1.37	0.42	0.74	0.12	0.45	0.03	0.25	0.01	0.18								
2	6.74	2.74	1.52	1.48	0.44	0.89	0.11	0.50	0.05	0.36	0.01	0.22						
3	14.29	4.11	3.21	2.23	0.93	1.34	0.23	0.75	0.10	0.54	0.03	0.33	0.01	0.23				
4	24.34	5.48	5.47	2.97	1.59	1.78	0.39	1.00	0.18	0.73	0.05	0.43	0.02	0.30				
5	36.79	6.85	8.27	3.71	2.40	2.23	0.59	1.25	0.27	0.91	0.08	0.54	0.03	0.38	0.01	0.24		
6	51.57	8.22	11.59	4.45	3.36	2.68	0.82	1.50	0.38	1.09	0.11	0.65	0.04	0.45	0.02	0.29		
7	68.61	9.59	15.43	5.19	4.47	3.12	1.09	1.75	0.50	1.27	0.14	0.76	0.06	0.53	0.02	0.34		
8	87.86	10.96	19.75	5.94	5.73	3.57	1.40	2.00	0.64	1.45	0.18	0.87	0.08	0.61	0.03	0.39		
9	109.27	12.33	24.57	6.68	7.12	4.01	1.74	2.25	0.80	1.63	0.23	0.98	0.01	0.68	0.03	0.44		
10	132.82	13.70	29.86	7.42	8.66	4.46	2.12	2.50	0.97	1.82	0.28	1.09	0.12	0.76	0.04	0.49		
11			35.63	8.16	10.33	4.91	2.53	2.75	1.16	2.00	0.33	1.20	0.14	0.83	0.05	0.53		
12			41.86	8.90	12.14	5.35	2.97	3.00	1.36	2.18	0.39	1.30	0.16	0.91	0.06	0.58		
14			55.69	10.39	16.15	6.24	3.95	3.50	1.81	2.54	0.52	1.52	0.22	1.06	0.07	0.68		
16			71.31	11.87	20.68	7.14	5.06	4.00	2.32	2.90	0.67	1.74	0.28	1.21	0.09	0.78		
18			88.69	13.36	25.72	8.03	6.30	4.50	2.89	3.27	0.83	1.96	0.34	1.36	0.12	0.87		
20			107.80	14.84	31.26	8.92	7.65	5.00	3.51	3.63	1.01	2.17	0.42	1.51	0.14	0.97	0.04	0.56
22					37.29	9.81	9.13	5.50	4.19	3.99	1.20	2.39	0.50	1.67	0.17	1.07	0.04	0.61
24					43.81	10.70	10.72	6.00	4.92	4.36	1.41	2.61	0.59	1.82	0.20	1.17	0.05	0.67
26					50.81	11.60	12.44	6.50	5.71	4.72	1.64	2.83	0.68	1.97	0.23	1.26	0.06	0.73
28					58.29	12.49	14.27	7.00	6.55	5.08	1.88	3.04	0.78	2.12	0.26	1.36	0.07	0.78
30					66.23	13.38	16.21	7.50	7.44	5.45	2.13	3.26	0.89	2.27	0.30	1.46	0.08	0.84
35							21.57	8.75	9.89	6.35	2.84	3.80	1.18	2.65	0.40	1.70	0.10	0.98
40							27.62	10.00	12.67	7.26	3.63	4.35	1.51	3.03	0.51	1.94	0.13	1.12
45							34.36	11.25	15.76	8.17	4.52	4.89	1.88	3.41	0.64	2.19	0.17	1.26
50	0.03	0.62					41.76	12.51	19.16	9.08	5.49	5.44	2.28	3.78	0.77	2.43	0.20	1.40
55	0.03	0.68					49.82	13.76	22.85	9.99	6.55	5.98	2.72	4.16	0.92	2.67	0.24	1.53
60	0.04	0.74					58.53	15.01	26.85	10.89	7.70	6.52	3.20	4.54	1.09	2.91	0.28	1.67
65	0.04	0.80							31.14	11.80	8.93	7.07	3.71	4.92	1.26	3.16	0.33	1.81
70	0.05	0.86							35.72	12.71	10.24	7.61	4.25	5.30	1.45	3.40	0.38	1.95
75	0.06	0.92							40.59	13.62	11.64	8.15	4.83	5.68	1.64	3.64	0.43	2.09
80	0.07	0.98							45.74	14.52	13.12	8.70	5.45	6.06	1.85	3.89	0.48	2.23
85	0.07	1.05							51.18	15.43	14.68	9.24	6.09	6.43	2.07	4.13	0.54	2.37
90	0.08	1.11							56.89	16.34	16.32	9.78	6.77	6.81	2.30	4.37	0.60	2.51
95	0.09	1.17							62.88	17.25	18.03	10.33	7.49	7.19	2.54	4.61	0.66	2.65
100	0.01	1.23							69.15	18.16	19.83	10.87	8.23	7.57	2.80	4.86	0.73	2.79
125	0.15	1.54									29.98	13.59	12.45	9.46	4.23	6.07	1.01	3.49
150	0.21	1.85									42.02	16.31	17.45	11.35	5.93	7.29	1.54	4.19
175	0.28	2.15											23.21	13.25	7.89	8.50	2.05	4.88

Note: Suction velocities should not exceed 8 feet per second. Calculated using Williams and Hazen formula using C = 150.

Friction Loss

Water in Feet per 100 feet of Steel Pipe

GPM	Pipe Size 1/2"			Pipe Size 3/4"			Pipe Size 1"			Pipe Size 1-1/4"			Pipe Size 1-1/2"		
	Actual size 0.622			Actual size 0.824			Actual size 1.049			Actual size 1.38			Actual size 1.61		
	Friction	Vel (ft/sec)	Vel Head (ft)	Friction	Vel (ft/sec)	Vel Head (ft)	Friction	Vel (ft/sec)	Vel Head (ft)	Friction	Vel (ft/sec)	Vel Head (ft)	Friction	Vel (ft/sec)	Vel Head (ft)
1	2.099	1.056	0.017	0.534	0.602	0.006	0.165	0.371	0.002	0.043	0.215	0.001	0.021	0.158	0.000
2	7.577	2.112	0.069	1.929	1.203	0.023	0.596	0.742	0.009	0.157	0.429	0.003	0.074	0.315	0.002
3	16.056	3.168	0.156	4.087	1.805	0.051	1.263	1.114	0.019	0.332	0.644	0.006	0.157	0.473	0.003
4	27.354	4.223	0.277	6.962	2.407	0.090	2.151	1.485	0.034	0.566	0.858	0.011	0.268	0.630	0.006
5	41.352	5.279	0.433	10.525	3.008	0.141	3.252	1.856	0.054	0.856	1.073	0.018	0.404	0.788	0.001
6	57.961	6.335	0.624	14.753	3.610	0.203	4.558	2.227	0.077	1.200	1.287	0.026	0.567	0.946	0.014
7	77.112	7.391	0.849	19.628	4.211	0.276	6.064	2.599	0.105	1.597	1.502	0.035	0.754	1.103	0.019
8	98.747	8.447	1.109	25.134	4.813	0.360	7.765	2.970	0.137	2.045	1.716	0.046	0.966	1.261	0.025
9	122.817	9.503	1.404	31.261	5.415	0.456	9.657	3.341	0.173	2.543	1.931	0.058	1.201	1.418	0.031
10	149.280	10.559	1.733	37.997	6.016	0.563	11.738	3.712	0.214	3.091	2.145	0.072	1.460	1.576	0.039
11	178.099	11.615	2.097	45.332	6.618	0.681	14.004	4.083	0.259	3.688	2.360	0.087	1.742	1.734	0.047
12	209.241	12.670	2.495	53.259	7.220	0.810	16.453	4.455	0.308	4.333	2.574	0.103	2.047	1.891	0.056
13	242.675	13.726	2.928	61.769	7.821	0.951	19.082	4.826	0.362	5.025	2.789	0.121	2.374	2.049	0.065
14	278.376	14.782	3.396	70.856	8.423	1.103	21.889	5.197	0.420	5.764	3.003	0.140	2.723	2.206	0.076
15	316.317	15.838	3.899	80.513	9.025	1.266	24.873	5.568	0.482	6.550	3.218	0.161	3.094	2.364	0.087
16				90.735	9.626	1.440	28.031	5.940	0.548	7.381	3.432	0.183	3.487	2.521	0.099
17				101.517	10.228	1.626	31.362	6.311	0.619	8.258	3.647	0.207	3.901	2.679	0.112
18				112.852	10.829	1.823	34.863	6.682	0.694	9.181	3.861	0.232	4.337	2.837	0.125
19				124.738	11.431	2.031	38.535	7.053	0.773	10.148	4.076	0.258	4.793	2.994	0.139
20				137.168	12.033	2.250	42.375	7.425	0.857	11.159	4.290	0.286	5.271	3.152	0.154
21				150.140	12.634	2.481	46.383	7.796	0.945	12.214	4.505	0.315	5.769	3.309	0.170
22				163.649	13.236	2.723	50.556	8.167	1.037	13.313	4.719	0.346	6.288	3.467	0.187
23				177.691	13.838	2.976	54.894	8.538	1.133	14.455	4.934	0.378	6.828	3.625	0.204
24				192.263	14.439	3.241	59.396	8.909	1.234	15.641	5.148	0.412	7.388	3.782	0.222
25				207.363	15.041	3.516	64.061	9.281	1.339	16.869	5.363	0.447	7.968	3.940	0.241
26				222.985	15.643	3.803	68.887	9.652	1.448	18.140	5.577	0.483	8.569	4.097	0.261
27				239.128	16.244	4.101	73.874	10.023	1.561	19.453	5.792	0.521	9.189	4.255	0.281
28				255.789	16.846	4.411	79.021	10.394	1.679	20.809	6.006	0.561	9.829	4.413	0.303
29				272.965	17.448	4.731	84.327	10.766	1.801	22.206	6.221	0.601	10.489	4.570	0.325
30				290.652	18.049	5.063	89.791	11.137	1.928	23.645	6.435	0.644	11.169	4.728	0.347
32							101.191	11.879	2.193	26.647	6.864	0.732	12.587	5.043	0.395
34							113.215	12.622	2.476	29.813	7.293	0.827	14.082	5.358	0.446
36							125.857	13.364	2.776	33.142	7.722	0.927	15.655	5.673	0.500
38							139.112	14.107	3.093	36.633	8.151	1.033	17.304	5.989	0.557
40							152.975	14.849	3.427	40.283	8.580	1.144	19.028	6.304	0.618
42							167.442	15.592	3.778	44.093	9.009	1.261	20.827	6.619	0.681
44							182.507	16.334	4.147	48.060	9.438	1.384	22.701	6.934	0.747
46							198.168	17.076	4.532	52.184	9.867	1.513	24.649	7.249	0.817
48							214.420	17.819	4.935	56.463	10.296	1.648	26.671	7.564	0.889
50							231.259	18.561	5.355	60.898	10.725	1.788	28.765	7.880	0.965
55							275.904	20.417	6.479	72.654	11.798	2.163	34.319	8.668	1.168
60							324.147	22.274	7.711	85.358	12.870	2.574	40.319	9.456	1.390
65							375.943	24.130	9.049	98.997	13.943	3.021	46.762	10.244	1.631
70							431.249	25.986	10.495	113.561	15.015	3.504	53.641	11.032	1.891
75							490.027	27.842	12.048	129.039	16.088	4.023	60.952	11.820	2.171
80							552.241	29.698	13.708	145.422	17.160	4.577	68.691	12.607	2.470
85							617.860	31.554	15.475	162.701	18.233	5.167	76.853	13.395	2.789
90							686.852	33.410	17.349	180.869	19.305	5.793	85.435	14.183	3.127
95							759.190	35.267	19.331	199.918	20.378	6.454	94.433	14.971	3.484
100							834.846	37.123	21.419	219.840	21.450	7.151	103.843	15.759	3.860
110										262.281	23.595	8.653	123.890	17.335	4.671
120										308.142	25.740	10.298	145.553	18.911	5.559
130										357.380	27.885	12.086	168.811	20.487	6.524
140										409.955	30.030	14.016	193.645	22.063	7.566
150										465.831	32.175	16.090	220.039	23.639	8.685

Note: Suction velocities should not exceed 8 feet per second.

References

Friction Loss

Water in Feet per 100 feet of Steel Pipe



GPM	Pipe Size 2"			Pipe Size 2.5"			Pipe Size 3"			Pipe Size 3.5"		
	Actual size 2.067			Actual size 2.469			Actual size 3.068			Actual size 3.548		
	Friction	Vel (ft/sec)	Vel Head (ft)	Friction	Vel (ft/sec)	Vel Head (ft)	Friction	Vel (ft/sec)	Vel Head (ft)	Friction	Vel (ft/sec)	Vel Head (ft)
2	0.022	0.191	0.001									
3	0.047	0.287	0.001	0.020	0.201	0.001						
4	0.079	0.383	0.002	0.033	0.268	0.001						
5	0.120	0.478	0.004	0.051	0.335	0.002	0.018	0.217	0.001	0.009	0.162	0.000
6	0.168	0.574	0.005	0.071	0.402	0.003	0.025	0.260	0.001	0.012	0.195	0.001
7	0.224	0.670	0.007	0.094	0.469	0.003	0.033	0.304	0.001	0.016	0.227	0.001
8	0.286	0.765	0.009	0.121	0.536	0.004	0.042	0.347	0.002	0.021	0.260	0.001
9	0.356	0.861	0.012	0.150	0.603	0.006	0.052	0.391	0.002	0.026	0.292	0.001
10	0.433	0.957	0.014	0.182	0.670	0.007	0.063	0.434	0.003	0.031	0.325	0.002
11	0.516	1.052	0.017	0.218	0.737	0.008	0.076	0.477	0.004	0.037	0.357	0.002
12	0.607	1.148	0.020	0.256	0.804	0.010	0.089	0.521	0.004	0.044	0.389	0.002
13	0.704	1.244	0.024	0.296	0.871	0.012	0.103	0.564	0.005	0.051	0.422	0.003
14	0.807	1.339	0.028	0.340	0.938	0.014	0.118	0.608	0.006	0.058	0.454	0.003
15	0.917	1.435	0.032	0.386	1.005	0.016	0.134	0.651	0.007	0.066	0.487	0.004
16	1.034	1.531	0.036	0.435	1.072	0.018	0.151	0.694	0.007	0.075	0.519	0.004
17	1.157	1.626	0.041	0.487	1.139	0.020	0.169	0.738	0.008	0.083	0.552	0.005
18	1.286	1.722	0.046	0.542	1.206	0.023	0.188	0.781	0.009	0.093	0.584	0.005
19	1.421	1.818	0.051	0.599	1.273	0.025	0.208	0.825	0.011	0.103	0.617	0.006
20	1.563	1.913	0.057	0.658	1.340	0.028	0.229	0.868	0.012	0.113	0.649	0.007
21	1.711	2.009	0.063	0.720	1.407	0.031	0.250	0.911	0.013	0.123	0.681	0.007
22	1.865	2.105	0.069	0.785	1.474	0.034	0.273	0.955	0.014	0.135	0.714	0.008
23	2.025	2.200	0.075	0.853	1.541	0.037	0.296	0.998	0.015	0.146	0.746	0.009
24	2.191	2.296	0.082	0.923	1.608	0.040	0.321	1.042	0.017	0.158	0.779	0.009
25	2.363	2.391	0.089	0.995	1.675	0.044	0.346	1.085	0.018	0.171	0.811	0.010
26	2.541	2.487	0.096	1.070	1.742	0.047	0.372	1.128	0.020	0.183	0.844	0.011
27	2.724	2.583	0.104	1.148	1.809	0.051	0.399	1.172	0.021	0.197	0.876	0.012
28	2.914	2.678	0.112	1.227	1.876	0.055	0.427	1.215	0.023	0.210	0.909	0.013
29	3.110	2.774	0.120	1.310	1.943	0.059	0.455	1.259	0.025	0.224	0.941	0.014
30	3.312	2.870	0.128	1.395	2.010	0.063	0.485	1.302	0.026	0.239	0.974	0.015
32	3.732	3.061	0.146	1.572	2.144	0.071	0.546	1.389	0.030	0.269	1.038	0.017
34	4.175	3.252	0.164	1.759	2.278	0.081	0.611	1.476	0.034	0.301	1.103	0.019
36	4.642	3.444	0.184	1.955	2.412	0.090	0.679	1.562	0.038	0.335	1.168	0.021
38	5.130	3.635	0.205	2.161	2.546	0.101	0.751	1.649	0.042	0.370	1.233	0.024
40	5.642	3.826	0.228	2.376	2.680	0.112	0.826	1.736	0.047	0.407	1.298	0.026
42	6.175	4.018	0.251	2.601	2.814	0.123	0.904	1.823	0.052	0.446	1.363	0.029
44	6.731	4.209	0.275	2.835	2.948	0.135	0.985	1.910	0.057	0.486	1.428	0.032
46	7.308	4.400	0.301	3.078	3.083	0.148	1.070	1.996	0.062	0.527	1.493	0.035
48	7.908	4.592	0.328	3.331	3.217	0.161	1.158	2.083	0.067	0.571	1.558	0.038
50	8.529	4.783	0.356	3.592	3.351	0.174	1.248	2.170	0.073	0.616	1.623	0.041
55	10.175	5.261	0.430	4.286	3.686	0.211	1.490	2.387	0.089	0.734	1.785	0.050
60	11.955	5.740	0.512	5.035	4.021	0.251	1.750	2.604	0.105	0.863	1.947	0.059
65	13.865	6.218	0.601	5.840	4.356	0.295	2.030	2.821	0.124	1.001	2.109	0.069
70	15.905	6.696	0.697	6.699	4.691	0.342	2.328	3.038	0.143	1.148	2.272	0.080
75	18.072	7.174	0.800	7.612	5.026	0.393	2.646	3.255	0.165	1.304	2.434	0.092
80	20.367	7.653	0.910	8.578	5.361	0.447	2.981	3.472	0.187	1.470	2.596	0.105
85	22.787	8.131	1.028	9.598	5.696	0.504	3.336	3.689	0.212	1.644	2.758	0.118
90	25.331	8.609	1.152	10.669	6.031	0.565	3.708	3.906	0.237	1.828	2.921	0.133
95	27.999	9.088	1.284	11.793	6.366	0.630	4.099	4.123	0.264	2.021	3.083	0.148
100	30.789	9.566	1.422	12.968	6.701	0.698	4.507	4.340	0.293	2.222	3.245	0.164
110	36.733	10.523	1.721	15.472	7.371	0.845	5.377	4.774	0.354	2.651	3.570	0.198
120	43.156	11.479	2.048	18.177	8.041	1.005	6.317	5.208	0.422	3.114	3.894	0.236
130	50.052	12.436	2.404	21.081	8.711	1.180	7.327	5.642	0.495	3.612	4.219	0.277
140	57.416	13.392	2.788	24.183	9.382	1.368	8.405	6.076	0.574	4.144	4.543	0.321
150	65.241	14.349	3.200	27.479	10.052	1.570	9.550	6.510	0.659	4.708	4.868	0.368

Note: Suction velocities should not exceed 8 feet per second.

References

Pipe Fittings

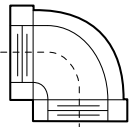
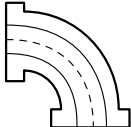
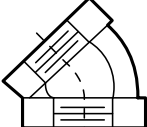
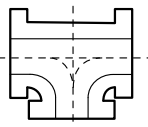
Friction Losses in Terms of Equivalent Lengths of Standard Pipe

Pipe Size	Standard 90 ° Elbow	Long Radius Elbow	45 ° Elbow	Tee	Return Bend
					
1/2"	1.5	1.1	0.77	3.4	3.8
3/4"	2.2	1.4	1	4.5	5
1"	2.7	1.7	1.3	5.8	6.1
1-1/4"	3.7	2.4	1.6	7.8	8.5
1.5"	4.3	2.8	2	9	10
2"	5.5	3.5	2.5	11	13
2.5"	6.5	4.2	3	14	15
3"	8.1	5.1	3.8	17	18
3.5"	9.5	6	4.4	19	21
4"	11	7	5	22	24
4.5"	12	7.9	5.6	24	27
5"	14	8.9	6.1	27	31
6"	16	11	7.7	33	37

Friction Losses in Terms of Equivalent Lengths of Standard Pipe

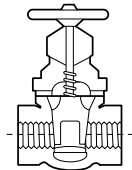
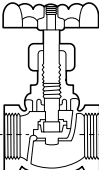
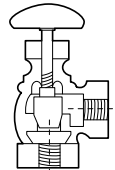
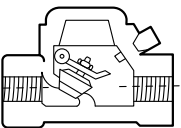
Pipe Size	Gate Valve Open	Globe Valve Open	Angle Valve Open	Swing Check Valve
				
1/2"	0.35	16	8.4	4
3/4"	0.47	22	12	5
1"	0.6	27	15	7
1-1/4"	0.8	37	18	9
1.5"	0.95	44	22	11
2"	1.2	57	28	13
2.5"	1.4	66	33	16
3"	1.7	85	42	20
3.5"	2	99	50	
4"	2.3	110	58	26
4.5"	2.6	130	61	
5"	2.9	140	70	33
6"	3.5	160	83	39

References

Pressure Loss

Swing Check Valves

Flow GPM	Pressure Loss (PSI)					
	Valve Size					
	1/2"	3/4"	1"	1-1/4"	1.5"	2"
2	0.2					
3	.05					
6	1.0	0.3				
8	1.7	0.5				
10	2.6	0.8	0.3			
12	3.6	1.1	0.5			
14	4.8	1.5	0.6			
16		2.0	0.9			
18		2.4	1.0			
20		3.0	1.2	0.4		
22		3.5	1.4	0.5		
24		4.1	1.7	0.6		
26		4.8	2.0	0.7	0.4	
28			2.2	0.8	0.5	
30			2.5	0.9	0.5	
32			2.9	1.1	0.6	
34			3.2	1.2	0.6	
36			3.6	1.3	0.7	
38			3.9	1.5	0.8	
40			4.3	1.6	0.8	0.3
42			4.7	1.7	0.9	0.3
44				1.9	1.0	0.4

Flow GPM	Pressure Loss (PSI)					
	Valve Size					
	1-1/4"	1.5"	2"	2.5"	3"	4"
46	2.1	1.1	0.4			
48	2.2	1.2	0.5			
50	2.4	1.3	0.5			
55	2.9	1.5	0.6			
60	3.4	1.8	0.7			
65	3.9	2.0	0.8			
70	4.5	2.4	0.9	0.4		
75		2.7	1.0	0.5		
80		3.0	1.2	0.6		
90		3.7	1.5	0.7		
100		4.6	1.8	0.9	0.4	
120			2.5	1.2	0.5	
140			3.3	1.6	0.7	

Bronze Gate Valves

Flow GPM	Pressure Loss (PSI)									
	Valve Size									
	1/2"	3/4"	1"	1-1/4"	1.5"	2"	2.5"	3"	4"	
1										
2	.01									
5	.06	.02								
8	.16	.05	.02							
10	.24	.08	.03	.01						
15		.17	.06	.02	.01					
20		.31	.11	.03	.02					
30			.24	.07	.04	.01				
40			.43	.13	.07	.02	.01			
50			.67	.21	.11	.04	.02			
60				.30	.15	.05	.03	.01		
80				.54	.28	.10	.05	.02		
100					.43	.15	.07	.03		
120					.62	.22	.10	.04	.02	
140					.85	.30	.14	.06		
160						.40	.18	.07	.03	

Pressure Loss

Water Meters - AWWA Standard

Flow GPM	Pressure Loss						
	Normal Size						
	5/8"	3/4"	1"	1.5"	2"	3"	4"
1	0.2	0.1					
2	0.3	0.2					
3	0.4	0.3					
4	0.6	0.5	0.1				
5	0.9	0.6	0.2				
6	1.3	0.7	0.3				
7	1.8	0.8	0.4				
8	2.3	1.0	0.5				
9	3.0	1.3	0.6				
10	3.7	1.6	0.7				
11	4.4	1.9	0.8				
12	5.1	2.2	0.9				
13	6.1	2.6	1.0				
14	7.2	3.1	1.1				
15	8.3	3.6	1.2				
16	9.4	4.1	1.4	0.4			
17	10.7	4.6	1.6	0.5			
18	12.0	5.2	1.8	0.6			
19	13.4	5.8	2.0	0.7			
20	15.0	6.5	2.2	0.8			
22		7.9	2.8	1.0			
24		9.5	3.4	1.2			
26		11.2	4.0	1.4			
28		13.0	4.6	1.6			
30		15.0	5.3	1.8	0.7		
32			6.0	2.1	0.8		
34			6.9	2.4	0.9		
36			7.8	2.7	1.0		
38			8.7	3.0	1.2		
40			9.6	3.3	1.3		
42			10.6	3.6	1.4		
44			11.7	3.9	1.5		
46			12.8	4.2	1.6		
48			13.9	4.5	1.7		
50			15.0	4.9	1.9		
52				5.3	2.1		
54				5.7	2.2		
56				6.2	2.3		
58				6.7	2.5		
60				7.2	2.7	1.0	
65				8.3	3.2	1.1	
70				9.8	3.7	1.3	
75				11.3	4.3	1.5	
80				12.8	4.9	1.6	0.7
90				16.1	6.2	2.0	0.8
100				20.0	7.8	2.5	0.9
110					9.5	2.9	1.0
120					11.3	3.4	1.2
130					13.0	3.9	1.4
140					15.1	4.5	1.6
150					17.3	5.1	1.8

References

Pressure Tank Sizing

Pressure Tank Selection Chart - Minimum tank volumes for proper system life

Pump Capacity		Minimum Drawdown	Total Tank Volume (Gallons)								
			Switch Setting (PSI)								
GPH	GPM	Gallons	20-40			30-50			40-60		
			A	B	C	A	B	C	A	B	C
240	4	4	10	15	25	15	15	40	15	15	55
300	5	5	15	15	30	15	20	50	20	20	70
360	6	6	15	20	40	20	20	60	20	25	85
420	7	7	20	20	45	35	25	70	25	30	100
480	8	8	20	25	50	35	25	80	30	30	110
540	9	9	25	25	60	30	30	90	35	35	125
600	10	10	30	30	65	30	35	100	40	40	140
660	11	12	35	35	80	40	40	120	45	45	165
720	12	13	35	40	85	40	45	130	50	50	180
780	13	15	40	45	100	50	50	150	55	60	210
840	14	17	45	50	110	55	55	170	65	65	235
900	15	19	50	55	125	60	65	190	70	75	265
960	16	20	55	55	160	65	65	200	75	75	280
1020	17	23	6	65	150	75	75	230	85	90	320
1080	18	25	70	70	160	80	85	250	95	95	350
1140	19	27	75	75	175	85	90	270	100	105	375
1200	20	30	80	85	195	95	100	300	110	115	415
1260	21	33	90	90	215	105	110	330	125	125	460
1320	22	36	100	100	235	115	120	360	135	135	500
1380	23	38	105	105	345	125	125	380	140	145	530
1440	24	41	110	115	365	135	135	410	155	155	570
1500	25	44	120	120	385	140	145	440	165	165	610
1560	26	47	130	130	305	150	155	470	175	180	655
1620	27	50	135	140	325	160	165	500	185	190	700
1680	28	53	145	145	345	170	175	530	200	200	735
1740	29	57	155	160	370	185	185	570	215	215	790
1800	30	60	165	165	390	195	195	600	225	225	835

Note: A - Bladder or Diaphragm Tank Design
 B - Floating Wafer Tank Design
 C - Plain Steel Tank Design

Reference Tables

Equivalent Values of Pressure

Inches of Mercury	Feet of Water	PSI
1	1.13	0.49
2	2.26	0.98
3	3.39	1.47
4	4.52	1.95
5	5.65	2.44
6	6.78	2.93
7	7.91	3.42
8	9.04	3.91
9	10.17	4.4
10	11.3	4.89
11	12.45	5.39
12	13.57	5.87
13	14.7	6.37
14	15.82	6.86
15	16.96	7.35
16	18.09	7.84
17	19.22	8.33
18	20.35	8.82
19	21.75	9.31
20	22.6	9.8
21	23.78	10.3
22	24.88	10.8
23	26	11.28
24	27.15	11.75
25	26.26	12.25
26	29.4	12.73
27	30.52	13.23
28	31.65	13.73
29	32.8	14.22
29.929	33.947	14.697

Properties of Water

Temp. of Water (° F)	Pressure (ft Water)
60	0.59
70	0.84
80	1.17
90	1.61
100	2.19
110	2.94
120	3.91
130	5.14
140	6.67
150	8.58
160	10.9
170	13.8
180	17.3
190	21.6
200	26.6
210	32.6
212	34

Atmospheric Pressure at Various Elevations

Altitude Feet Above Sea Level	Atmospheric Pressure		
	Pounds per Square Inch (PSI)	Feet of Water	Inches of Mercury
Sea Level	14.7	33.8	29.9
500	14.4	33.3	29.4
1000	14.2	32.6	28.8
2000	13.7	31.4	27.8
3000	13.2	30.3	26.8
4000	12.7	29.2	25.8
5000	12.2	28.2	24.9
6000	11.8	27.1	24
7000	11.3	26.1	23.1
8000	10.9	25.1	22.2
9000	10.5	24.2	21.4
10000	10.1	23.2	20.6

References

Conversions

Head		
To Convert From	To	Multiply By
PSI	Feet	2.31
PSI	Inches of Mercury	2.04
Feet	PSI	0.433
Feet	Meters	0.305
Feet	Inches of Mercury	0.885
Inches of Mercury	Feet of Water	1.132
Meters	Feet	3.28
Kilograms per sq. in.	PSI	14.22
ATM	PSI	14.7
ATM	Feet of Water	34
ATM	Meters of Water	10.35

Volume		
To Convert From	To	Multiply By
Gallons	Liters	3.785
Gallons	Cubic Inches	231
Gallons	Cubic Feet	0.137
Gallons	Cubic Meters	0.004
Liters	Gallons	0.264
Barrel (Oil)	Gallons	42
Cubic Feet	Gallons	7.48
Cubic Feet	Cubic Meters	0.028
Acre Foot	Cubic Feet	43560
Acre Foot	Gallons	325829
Acre Inch	Cubic Feet	3630
Acre Inch	Gallons	27100

Capacity		
To Convert From	To	Multiply By
Gallons Per Minute	Liters/Sec.	0.063
Gallons Per Minute	Liters/Hr.	227.1
Gallons Per Minute	Cubic Meters/Hr.	0.227
Gallons Per Minute	Cubic Feet/Sec.	0.002
Gallons Per Minute	Pounds Per Hour	500
Cubic Meters/Hr.	Gallons Per Minute	4.402
Cubic Meters/Hr.	Liters/Sec.	0.278
Cubic Feet/Sec.	Gallons Per Minute	448.831
Acre Foot	Gallons	325.85
Acre Foot per Day	Gallons Per Minute	227
Acre Inch per Hour	Gallons Per Minute	454
Litre per Second	Gallons Per Minute	15.85
Miner's Inch ID,KS,NE, NM,ND,SD,UT,WA)	Gallons Per Minute	9
Miner's Inch (AZ,CA,MT,NV,OR)	Gallons Per Minute	11.22

Horsepower		
To Convert From	To	Multiply By
Hp	Kilowatts	0.746
Hp	Ft. lbs. per minute	33000
Hp	Ft. lbs. per second	550
Kilowatts	H.P.	1.341

Length		
To Convert From	To	Multiply By
Inches	Centimeters	2.54
Meters	Feet	3.28
Miles	Feet	5280
Rods	Feet	16.5

Weight		
To Convert From	To	Multiply By
Gallons	Pounds	8.33
Cubic Feet of Water	Pounds	62.35
Kilograms	Pounds	2.2

Temperature		
To Convert From	To	Multiply By
Fahrenheit	Celsius	$5/9 \times (^{\circ}F - 32)$
Celsius	Fahrenheit	$9/5 \times (^{\circ}C + 32)$

1,000,000 US gal. / day = 695 US gal. / minute

2- or 3-Wire Cable, 60 Hz

Service Entrance to Motor - Maximum Length in Feet

MOTOR RATING			60 °C INSULATION - AWG COPPER WIRE SIZE												
VOLTS	HP	KW	14	12	10	8	6	4	3	2	1	0	00	000	0000
115	1/2	.37	100	160	250	390	620	960	1190	1460	1780	2160	2630	3140	3770
	3/4	.55	300	480	760	1200	1870	2890	3580	4370	5330	6470	7870		
230	1	.75	250	400	630	990	1540	2380	2960	3610	4410	5360	6520		
	1.5	1.1	190	310	480	770	1200	1870	2320	2850	3500	4280	5240		
	2	1.5	150	250	390	620	970	1530	1910	2360	2930	3620	4480		
	3	2.2	120	190	300	470	750	1190	1490	1850	2320	2890	3610		
	5	3.7	0	0	180	280	450	710	890	1110	1390	1740	2170	2680	
	7.5	5.5	0	0	0	200	310	490	610	750	930	1140	1410	1720	
	10	7.5	0	0	0	0	250	390	490	600	750	930	1160	1430	1760
	15	11	0	0	0	0	170	270	340	430	530	660	820	1020	1260

MOTOR RATING			75 °C INSULATION - AWG COPPER WIRE SIZE												
VOLTS	HP	KW	14	12	10	8	6	4	3	2	1	0	00	000	0000
115	1/2	.37	100	160	250	390	620	960	1190	1460	1780	2160	2630	3140	3770
	3/4	.55	300	480	760	1200	1870	2890	3580	4370	5330	6470	7870	9380	
230	1	.75	250	400	630	990	1540	2380	2960	3610	4410	5360	6520	7780	9350
	1.5	1.1	190	310	480	770	1200	1870	2320	2850	3500	4280	5240	6300	7620
	2	1.5	150	250	390	620	970	1530	1910	2360	2930	3620	4480	5470	6700
	3	2.2	120	190	300	470	750	1190	1490	1850	2320	2890	3610	4470	5550
	5	3.7	0	110	180	280	450	710	890	1110	1390	1740	2170	2680	3330
	7.5	5.5	0	0	120	200	310	490	610	750	930	1140	1410	1720	2100
	10	7.5	0	0	0	160	250	390	490	600	750	930	1160	1430	1760
	15	11	0	0	0	0	170	270	340	430	530	660	820	1020	1260

1 Foot = .3048 Meter

Lengths in **BOLD** only meet the US National Electrical Code ampacity requirements for individual conductors 60 °C or 75 °C in free air or water, not in magnetic enclosures, conduit or direct buried. Lengths NOT in bold meet the NEC ampacity requirements for either individual conductors or jacketed 60 °C or 75 °C cable and can be in conduit or direct buried. Flat molded and web/ribbon cable are considered jacketed cable. If any other cable is used, the NEC and local codes should be observed.

Cable lengths allow for a 5% voltage drop running at maximum nameplate amperes. If 3% voltage drop is desired, multiply lengths by 0.6 to get maximum cable length. The portion of the total cable length, which is between the supply and single-phase control box with a line contactor, should not exceed 25% of total maximum allowable to ensure reliable contactor operation. Single-phase control boxes without line contactors may be connected at any point in the total cable length.

Values are based on copper wire. If aluminum wire is used, it must be two sizes larger than copper wire and oxidation inhibitors must be used on connections. **EXAMPLE:** #12 copper wire = #10 aluminum wire. Contact Franklin Electric for 90 °C cable lengths.

Warranty Information

Lost or Damaged Goods

IMPORTANT

Every carrier used by Franklin Electric, Inc. is required to verify and sign for the condition of and the number of pieces that are released to them for delivery. Our control and responsibility for any shipment ceases when the carrier signs the Bill of Lading. When you sign the Bill of Lading, you legally assume responsibility of the shipment being delivered. Please, thoroughly inspect each shipment immediately upon arrival.

If cartons, packages, or crates are received in short or damaged condition, it is important that you notify the driver and insist on a notation of the loss or damage across the face of the freight bill. Failure to do this could negate any opportunity you have to file a claim. Claims for short or damaged material must be filed in writing with the carrier immediately after delivery.

If concealed loss or damage is discovered, notify the carrier at once and request an inspection. It is also important that you do not discard the shipping carton or container. A concealed damage report should be made within ten (10) days of delivery of the shipment. The carrier's agent will make an inspection and usually will grant a concealed damage notation. If you give the carrier a clear receipt for the goods that have been damaged in transit, you do so at your own risk and expense.

We are willing to assist you to collect claims for loss or damage, but we are not responsible for collection of claims or replacement of material (shortage or damage) if not noted on the Bill of Lading at the time of delivery.

Due to frequent damage of heavy UPS shipments, Franklin Electric, Inc. does not ship orders over 75 lbs. by UPS unless customer agrees to take full responsibility.

For information or assistance contact:



Franklin Electric

Customer Service Department

800.269.0063

www.franklin-electric.com

Warranty Information

Limited Warranty

LIMITED WARRANTY*

THIS WARRANTY SETS FORTH THE COMPANY'S SOLE OBLIGATION AND PURCHASER'S EXCLUSIVE REMEDY FOR DEFECTIVE PRODUCT.

Franklin Electric Company, Inc. and its subsidiaries (hereafter "the Company") warrants that the products accompanied by this warranty are free from defects in material or workmanship of the Company.

The Company has the right to inspect any product returned under warranty to confirm that the product contains a defect in material or workmanship. The Company shall have the sole right to choose whether to repair or replace defective equipment, parts, or components.

The buyer should return the product to the place of purchase for warranty consideration. Subject to the terms and conditions listed below, the Company will repair or replace to the buyer any portion of this product which proves defective due to materials or workmanship of the Company.

The Company will consider products for warranty for 12 months (1-year) from the date of installation or for 24 months (2-years) from the date of manufacture, whichever occurs first. This limited warranty extends only to the products purchased directly from Franklin Electric and is not assignable or transferable to any subsequent purchaser or user.

The Company shall IN NO EVENT be responsible or liable for the cost of field labor or other charges incurred by any customer in removing and/or affixing any product, part or component thereof.

The Company reserves the right to change or improve its products or any portions thereof without being obligated to provide such change or improvement to previously sold products.

THIS WARRANTY DOES NOT APPLY TO products damaged by acts of God, including lightning, normal wear and tear, normal maintenance services and the parts used in connection with such service, or any other conditions beyond the control of the Company.

THIS WARRANTY WILL IMMEDIATELY VOID if any of the following conditions are found:

1. Product is used for purposes other than those for which it was designed and manufactured;
2. Product was not installed in accordance with applicable codes, ordinances and good trade practices;
3. Product was not installed by a Franklin Certified Contractor or Franklin Key Dealer; or
4. Product was damaged as a result of negligence, abuse, accident, misapplication, tampering, alteration, improper installation, operation, maintenance or storage, nor to an excess of recommended maximums as set forth in the product instructions.

NEITHER SELLER NOR THE COMPANY SHALL BE LIABLE FOR ANY INJURY, LOSS OR DAMAGE, DIRECT, INCIDENTAL OR CONSEQUENTIAL (INCLUDING, BUT NOT LIMITED TO, INCIDENTAL OR CONSEQUENTIAL DAMAGES FOR LOST PROFITS, LOST SALES, INJURY TO PERSON OR PROPERTY, OR ANY OTHER INCIDENTAL OR CONSEQUENTIAL LOSS), ARISING OUT OF THE USE OR THE INABILITY TO USE THE PRODUCT, AND THE BUYER AGREES THAT NO OTHER REMEDY SHALL BE AVAILABLE TO IT.

THE WARRANTY AND REMEDY DESCRIBED IN THIS LIMITED WARRANTY IS AN EXCLUSIVE WARRANTY AND REMEDY AND IS IN LIEU OF ANY OTHER WARRANTY OR REMEDY, EXPRESS OR IMPLIED, WHICH OTHER WARRANTIES AND REMEDIES ARE HEREBY EXPRESSLY EXCLUDED, INCLUDING BUT NOT LIMITED TO ANY IMPLIED WARRANTY OF MERCHANTABILITY OR FITNESS FOR A PARTICULAR PURPOSE, TO THE EXTENT EITHER APPLIES TO A PRODUCT SHALL BE LIMITED IN DURATION TO THE PERIODS OF THE EXPRESSED WARRANTIES GIVEN ABOVE.

DISCLAIMER: Any oral statements about the product made by the seller, the Company, the representatives or any other parties, do not constitute warranties, shall not be relied upon by the buyer, and are not part of the contract for sale. Seller's and the Company's only obligation, and buyer's only remedy, shall be the replacement and/or repair by the Company of the product as described above. Before using, the user shall determine the suitability of the product for his intended use, and user assumes all risk and liability whatsoever in connection therewith.

Some states and countries do not allow the exclusion or limitations on how long an implied warranty lasts or the exclusion or limitation of incidental or consequential damages, so the above exclusion or limitations may not apply to you. This warranty gives you specific legal rights, and you may also have other rights which vary from state to state and country to country.

*Contact Franklin Electric Co., Inc. Export Division for International Warranty.

WHERE THERE'S WATER, THERE'S FRANKLIN

COMPLETE PUMPING SYSTEMS

Whether you need water for household use, want to boost your pressure, or need to keep your basement dry, Franklin Electric has the right pumping system for the job. Call your local Franklin distributor to learn more.

franklinwater.com



Franklin Electric

MOVING WATER IS OUR BUSINESS

Residential Pumps | Irrigation Pumps | Industrial Pumps | Pressure Boosting | Sump, Effluent, Sewerage | WWC | Motors | Drives & Controls



Franklin Electric

9255 Coverdale Road, Fort Wayne, Indiana 46809
Tel: 260.824.2900 Fax: 260.824.2909

www.franklinwater.com