

EM-Series Dimensions

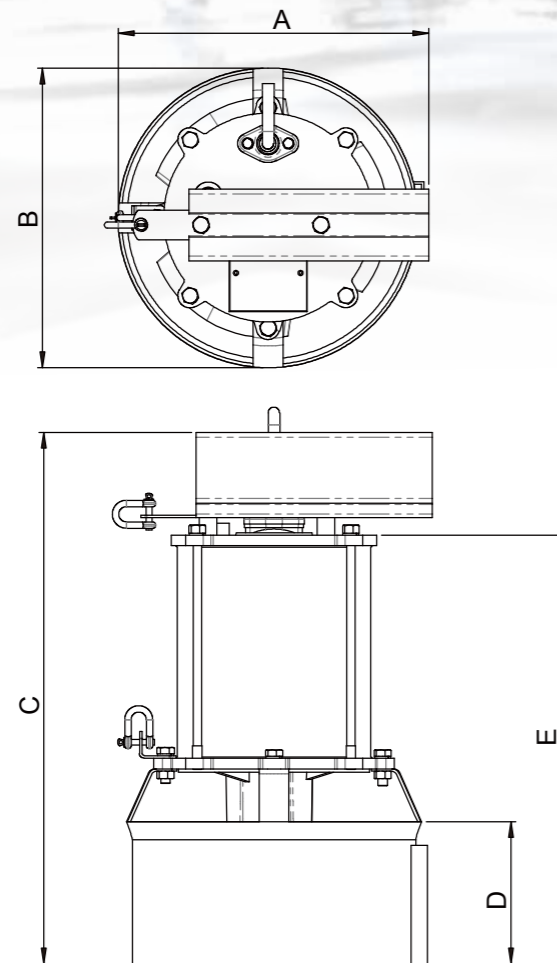

Dimensions (mm)						
Type	A	B	C	D	E	
EM-5.10	263	253	466	130	383	
EM-5.20	263	253	466	130	383	



**EVAK PUMP TECHNOLOGY CORP.**

No. 551, Zhongshan Rd., Qingshui Dist., Taichung City 436, Taiwan.  
 TEL: +886-426-233556 Fax: +886-426-235559

Vol/PEM-16031



**EM**  
**SERIES 50HZ**  
 Submersible Mixer



[www.evak-pumps.com](http://www.evak-pumps.com)



# EM SERIES 50HZ

Submersible Mixer

## Feature

- / The angular contact ball bearing resists to axial force
- / Compact design
- / More efficient bulk flow

## Application

- / Biological treatment tanks
- / Lime slurry storage tanks
- / Heat exchanger
- / Ponds and rivers water circulations
- / Equalization tanks

## Specifications

Liquid Temperature		0~40°C (32~104°F)
Submersible depth		6M
<b>Motor Part</b>	Frequency	50Hz
	Pole	6 Pole
	Type	Dry Type
	Insulation	Class B
	Protection	IP 68
<b>Mixer Part</b>	Protector	Auto-cut
	Bearing	Ball Type
	Mechanical seal	Dual. Mechanical Seal
	Impeller	Open



Open Impeller



EM-5.20



## Parts and Material List

No	Part	Material
1	Cable	
2	Shim	SUS 304
3	Switch plate	SUS 304
4	Thermal protector	
5	Bearing	NTN
6	Motor frame	SUS 304
7	Stator	
8	Shaft with Rotor	SUS 304
9	Bearing bracket	SUS 304
10	Bearing	NTN
11	Mech. seal	CA/CE+SIC/SIC
12	Seal bracket	SUS 304
13	Casing Shim	SUS 304
14	Impeller	SUS 304

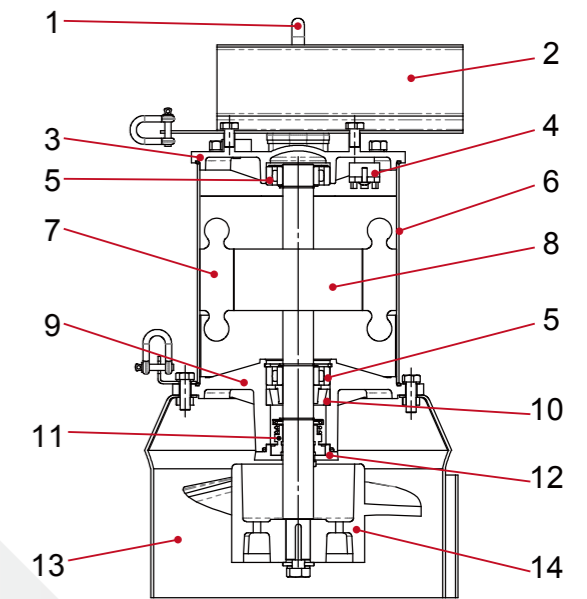

## Selection Table

Type	Output		Capacity M <sup>3</sup> /Min	Cable M
	HP	KW		
EM-5.10	1	0.75	3.2	6
EM-5.20	2	1.5	4.5	6