

Elettropompe Sommerse

Submersed Electropump

SP SERIES 4" SUBMERSIBLE PUMPS

Technical Catalogue

Catalogo Tecnico

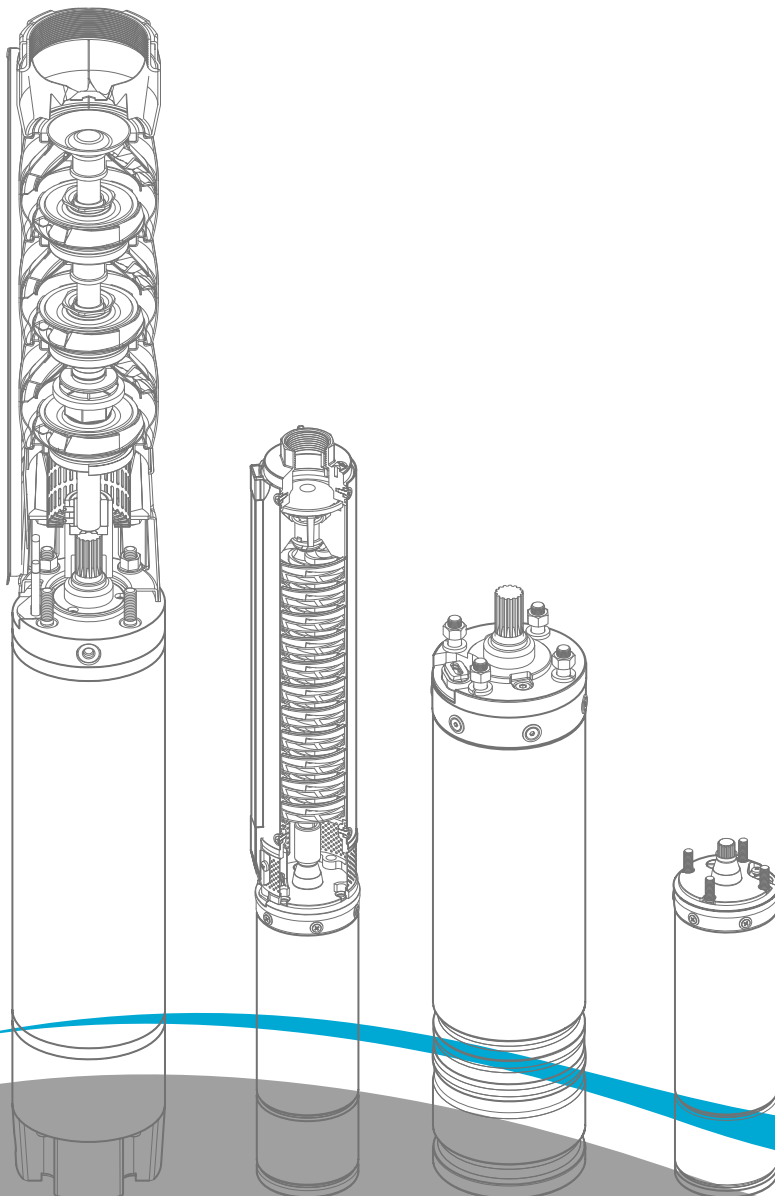

IRCEM
WATER PUMPS

SP SERIES 4" SUBMERSIBLE PUMPS

- Made completely of corrosion-resistant AISI 304 stainless steel, SP pumps are ideal for a wide variety of applications with high efficiency and reliability.

APPLICATIONS

- Water supply from deep well
- Agriculture irrigation
- Pressure boosting
- Fire-fighting
- Industrial application

SPECIFICATIONS

- Delivery: up to 19 m³/h at 2850 rpm.
- Head: up to 400 m at 2850 rpm.
- Maximum overall diameter of pump: 94 mm (cable guard included).
- Maximum permissible quantity of suspended sand: 150 g/m³.
- 1SP , 2SP , 3SP , 5SP versions: delivery port Rp1" 1/4.
- 8SP , 14SP versions: delivery port Rp2" .

MOTOR

- Motor power:
- Single-phase:
from 0,37 to 2,2 kW, 220 V, 50 Hz.
- Three-phase:
from 0,37 to 7,5 kW, 380 V, 50 Hz.

CONSTRUCTION & CHARACTERISTICS

- Sturdy and lightweight, easy to maintain and resistant to corrosion in non-aggressive environments.
- High efficient hydraulic design for cost saving and best performance.
- Stainless steel built-in non-return valve.
- Stainless steel impellers and diffusers.
- Stainless steel delivery port and suction support.
- Stainless steel shaft and replaceable coupling.
- Stainless steel floating wear ring & NBR bush bearings ensure maximum resistance to wear and long-lasting performance and reliability.
- Coupling and flange mounting dimensions meet NEMA standards.
- The SP series pumps can be coupled with the 4OS motors.

OPTIONAL FEATURES

- Different voltages and frequencies.



SP SERIES

HYDRAULIC PERFORMANCE RANGE AT 50 Hz

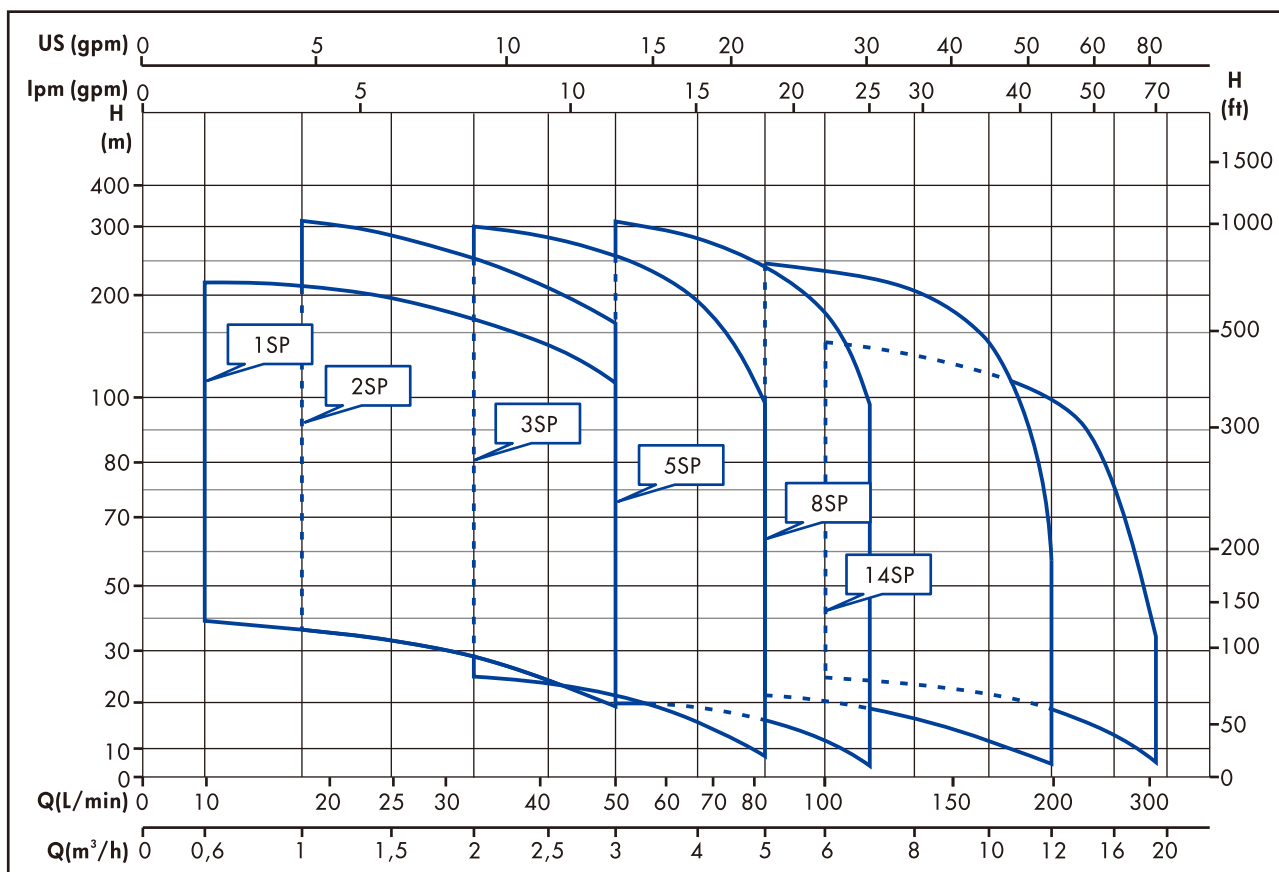

IDENTIFICATION CODE

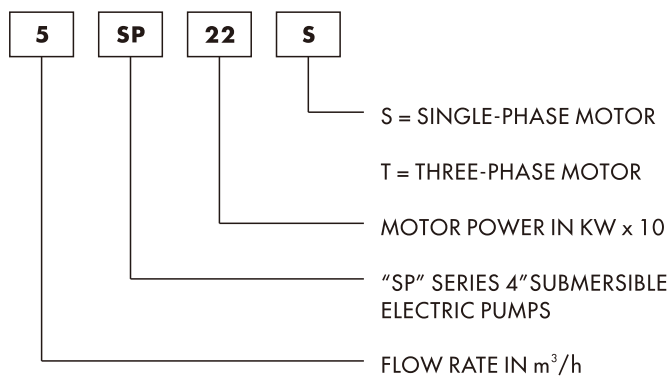

EXAMPLE OF PUMP TYPE

5SP22S

SP series submersible electric pump; flow rate 5 m³/h; coupled to a 4" submersible motor single phase 2,2 kW (3,0 Hp).



1SP-5SP SERIES

PUMP SECTION AND LIST OF MAIN COMPONENTS MATERIAL

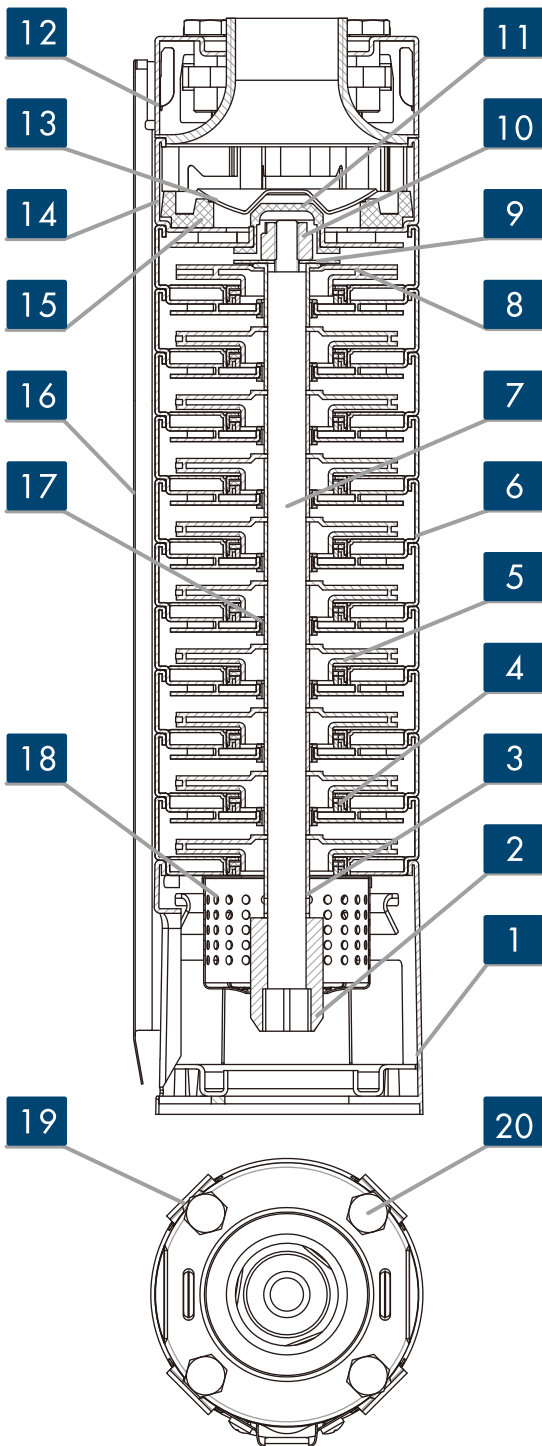

REF.N.	PART	MATERIAL	STANDARD
1	Lower support	Stainless steel	AISI 304
2	Coupling	Stainless steel	AISI 304
3	Shaft Sleeve	Stainless steel	AISI 304
4	Neck Ring	NBR	-----
5	Impeller	Stainless steel	AISI 304
6	Diffuser	Stainless steel	AISI 304
7	Shaft	Stainless steel	AISI 304
8	End-stage Impeller	Stainless steel	AISI 304
9	Thrust Washer	Stainless steel	AISI 304
10	Nut	Stainless steel	-----
11	Thrust Bearing	NBR	AISI 304
12	Delivery Port	Stainless steel	AISI 304
13	Non-return valve	Stainless steel	AISI 304
14	End-stage diffuser	Stainless steel	AISI 304
15	Valve Support	NBR	-----
16	Cable Guard	Stainless steel	AISI 304
17	Bush bearing	NBR	-----
18	Suction Inlet	Stainless steel	AISI 304
19	Strap	Stainless steel	AISI 304
20	Bolt	Stainless steel	AISI 304

8SP SERIES

PUMP SECTION AND LIST OF MAIN COMPONENTS MATERIAL

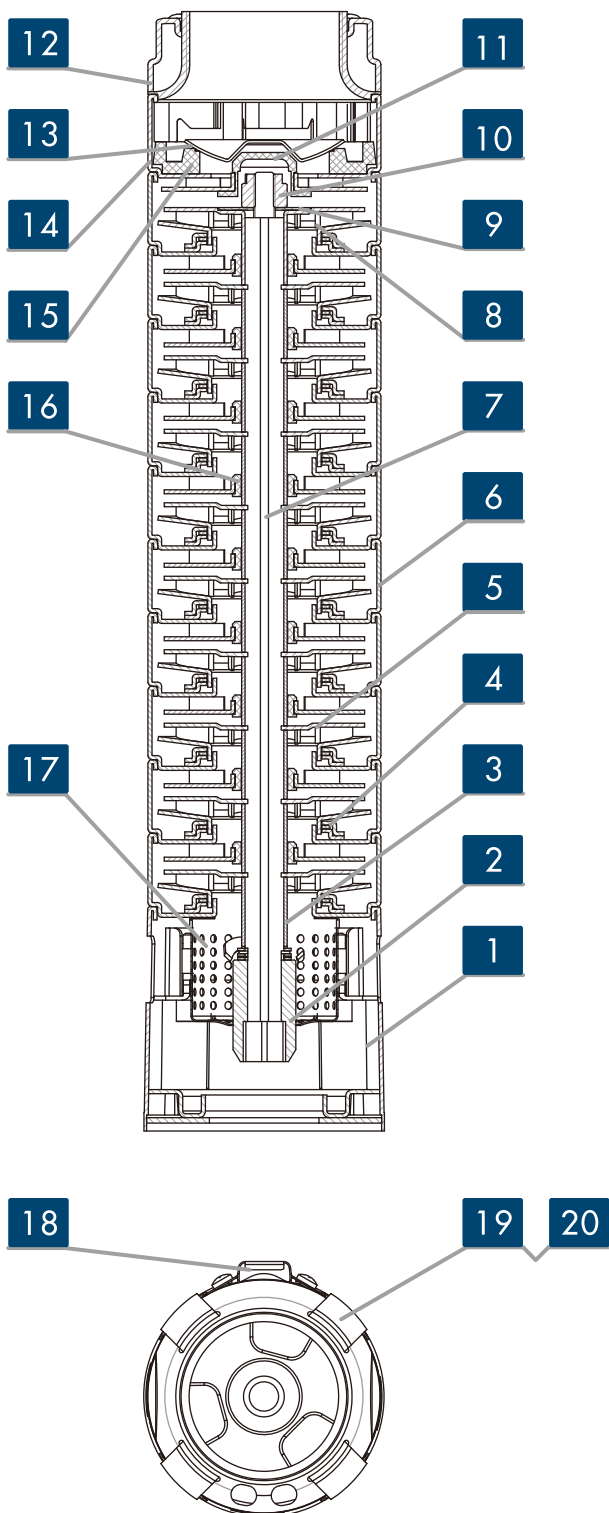

REF.N.	PART	MATERIAL	STANDARD
1	Lower support	Stainless steel	AISI 304
2	Coupling	Stainless steel	AISI 304
3	Shaft sleeve	Stainless steel	AISI 304
4	Neck ring	NBR	-----
5	Impeller	Stainless steel	AISI 304
6	Diffuser	Stainless steel	AISI 304
7	Shaft	Stainless steel	AISI 304
8	End-stage impeller	Stainless steel	AISI 304
9	Thrust washer	Stainless steel	AISI 304
10	Nut	Stainless steel	AISI 304
11	Thrust bearing	NBR	-----
12	Delivery port	Stainless steel	AISI 304
13	Non-return valve	Stainless steel	AISI 304
14	End-stage diffuser	Stainless steel	AISI 304
15	Valve support	NBR	-----
16	Bush bearing	NBR	-----
17	Suction inlet	Stainless steel	AISI 304
18	Cable guard	Stainless steel	AISI 304
19	Strap	Stainless steel	AISI 304
20	Bolt	Stainless steel	AISI 304

14SP SERIES

PUMP SECTION AND LIST OF MAIN COMPONENTS MATERIAL

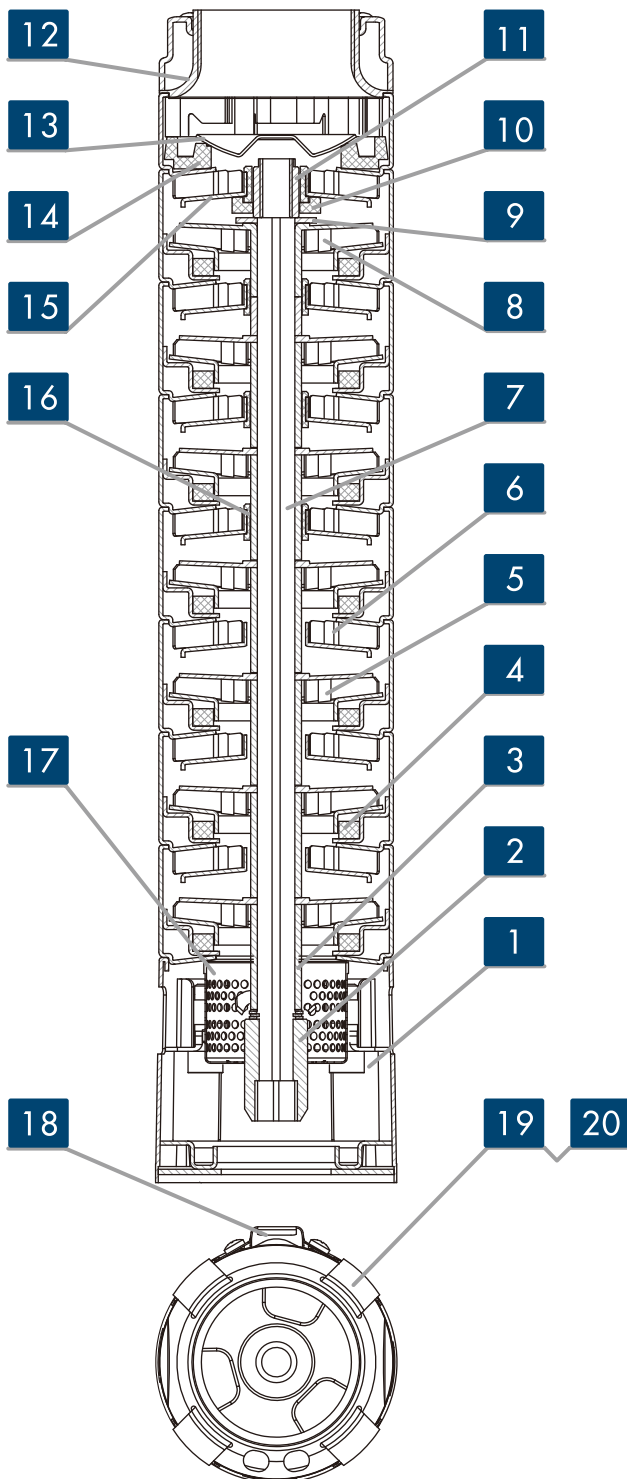

REF.N.	PART	MATERIAL	STANDARD
1	Lower support	Stainless steel	AISI 304
2	Coupling	Stainless steel	AISI 304
3	Shaft Sleeve	Stainless steel	AISI 304
4	Neck Ring	Stainless steel	AISI 304
5	Impeller	Stainless steel	AISI 304
6	Diffuser	Stainless steel	AISI 304
7	Shaft	Stainless steel	AISI 304
8	End-stage Impeller	Stainless steel	AISI 304
9	Thrust Washer	Stainless steel	AISI 304
10	Thrust Bearing	PTFE	-----
11	Nut	Stainless steel	AISI 304
12	Delivery Port	Stainless steel	AISI 304
14	Non-return valve	Stainless steel	AISI 304
13	Valve Support	NBR	-----
15	End-stage diffuser	Stainless steel	AISI 304
16	Bush bearing	NBR	-----
17	Suction Inlet	Stainless steel	AISI 304
18	Cable Guard	Stainless steel	AISI 304
19	Strap	Stainless steel	AISI 304
20	Bolt	Stainless steel	AISI 304

1 SP SERIES

OPERATING CHARACTERISTICS AT 50 Hz

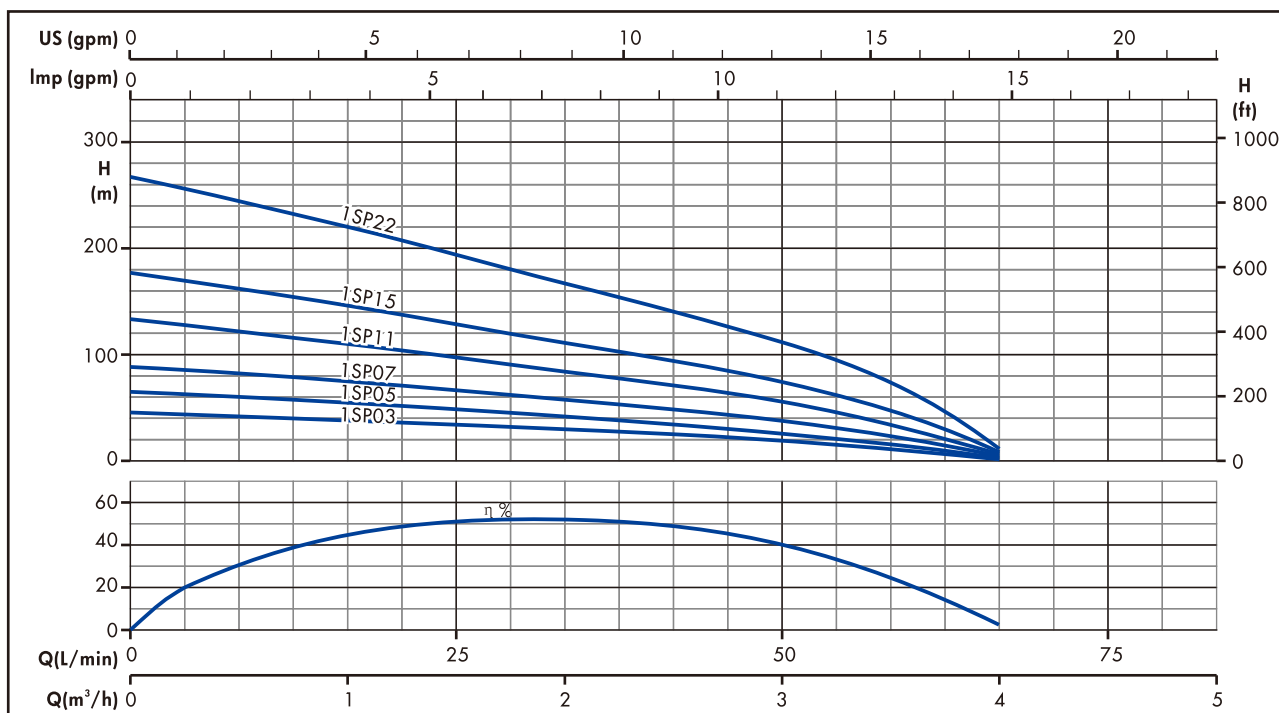

OPERATING CHARACTERISTICS AT 50 Hz

PUMP TYPE	N.OF STAGES	kW	Hp	Q = DELIVERY							
				L/min 0	10	17	25	33	40	50	67
				m³/h 0 0.6 1 1.5 2 2.5 3 4							
				H = TOTAL HEAD METERS COLUMN OF WATER							
1SP03S	7	0,37	0,5	45	39	37	32	29	24	19	1
1SP03T											
1SP05S	10	0,55	0,75	64	56	52	47	41	34	28	1
1SP05T											
1SP07S	14	0,75	1,0	88	78	73	66	57	48	38	2
1SP07T											
1SP11S	21	1,1	1,5	135	117	110	99	83	72	58	2
1SP11T											
1SP15S	28	1,5	2,0	178	157	147	133	110	96	75	3
1SP15T											
1SP22S	42	2,2	3,0	268	235	220	194	166	145	112	5
1SP22T											

DIMENSIONS AND WEIGHTS AT 50 Hz

PUMP TYPE	N.OF STAGE	DN	L1 mm	L mm	PUMP WEIGHT Kg	ELECTRIC PUMP WEIGHT Kg
1SP03S	7	Rp1"1/4	302	628	2,5	10,1
1SP03T				633		9,7
1SP05S	10		365	706	3,1	11,4
1SP05T				711		10,9
1SP07S	14		449	810	3,9	13,1
1SP07T				815		12,7
1SP11S	21		596	988	5,3	15,8
1SP11T				998		15,5
1SP15S	28		743	1175	6,7	19,1
1SP15T				1185		18,6
1SP22S	42		1037	1582	9,5	26,6
1SP22T				1557		26,2

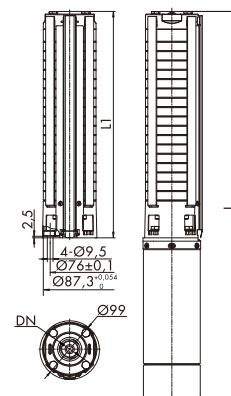

2SP SERIES

OPERATING CHARACTERISTICS AT 50 Hz

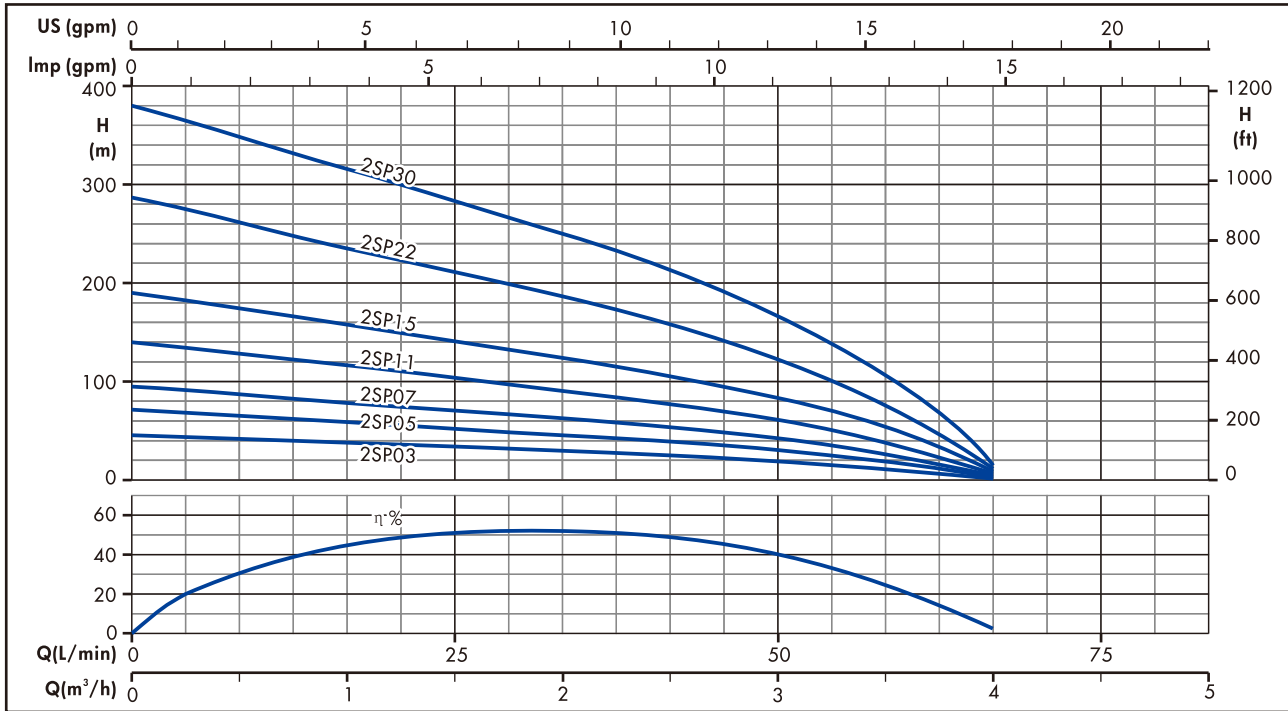

OPERATING CHARACTERISTICS AT 50 Hz

PUMP TYPE	N.OF STAGES	kW	Hp	Q=DELIVERY						
				L/min 0	17	25	33	40	50	67
				m³/h 0 1 1.5 2 2.5 3 4						
				H=TOTAL HEAD METERS COLUMN OF WATER						
2SP03S	7	0,37	0,5	44	37	32	29	25	19	1
2SP03T										
2SP05S	11	0,55	0,75	70	58	50	46	39	31	1
2SP05T										
2SP07S	15	0,75	1,0	95	78	70	63	52	42	2
2SP07T										
2SP11S	22	1,1	1,5	140	115	102	92	78	61	2
2SP11T										
2SP15S	30	1,5	2,0	190	157	140	125	106	83	3
2SP15T										
2SP22S	45	2,2	3,0	286	235	210	188	159	121	5
2SP22T										
2SP30T	60	3,0	4,0	380	313	280	251	213	167	7

DIMENSIONS AND WEIGHTS AT 50 Hz

PUMP TYPE	N.OF STAGE	DN	L1 mm	L mm	PUMP WEIGHT Kg	ELECTRIC PUMP WEIGHT Kg
2SP03S	7	Rp1"1/4	302	628	2,5	10,1
2SP03T				633		9,7
2SP05S	11		386	727	3,3	11,6
2SP05T				732		11,1
2SP07S	15		470	831	4,1	13,3
2SP07T				836		12,9
2SP11S	22		617	1009	5,5	16
2SP11T				1019		15,7
2SP15S	30		785	1217	7,1	19,5
2SP15T				1227		19
2SP22S	45		1100	1645	10,1	27,2
2SP22T				1620		26,8
2SP30T	60		1415	2010	13,1	32,9

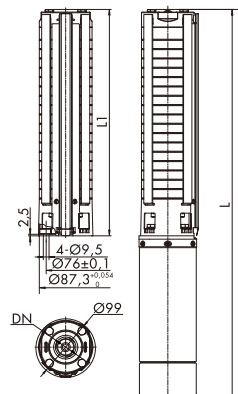

3SP SERIES

OPERATING CHARACTERISTICS AT 50 Hz

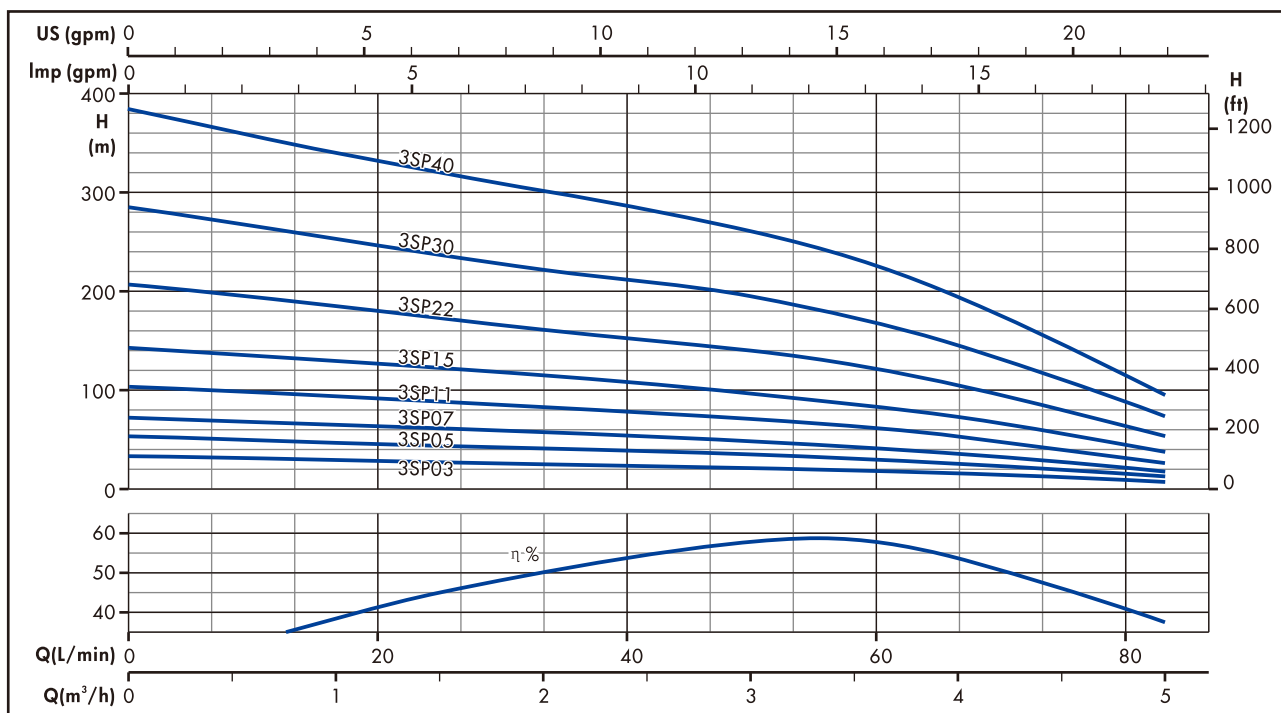

OPERATING CHARACTERISTICS AT 50 Hz

PUMP TYPE	N.OF STAGES	kW	Hp	Q=DELIVERY						
				L/min 0	17	33	40	50	67	83
				m³/h 0	1	2	2.5	3	4	5
				H=TOTAL HEAD METERS COLUMN OF WATER						
3SP03S	5	0,37	0,5	32	29	25	23	21	16	8
3SP03T										
3SP05S	8	0,55	0,75	52	46	40	37	35	26	13
3SP05T										
3SP07S	11	0,75	1,0	71	64	58	51	49	36	18
3SP07T										
3SP11S	16	1,1	1,5	103	92	81	75	71	52	27
3SP11T										
3SP15S	22	1,5	2,0	142	130	115	103	96	72	37
3SP15T										
3SP22S	32	2,2	3,0	207	185	160	149	140	104	53
3SP22T										
3SP30T	44	3,0	4,0	285	254	220	205	195	144	73
3SP40T	59	4,0	5,5	384	340	300	275	260	194	98

DIMENSIONS AND WEIGHTS AT 50 Hz

PUMP TYPE	N.OF STAGE	DN	L1 mm	L mm	PUMP WEIGHT Kg	ELECTRIC PUMP WEIGHT Kg
3SP03S	5	Rp1"1/4	260	586	2,1	9,7
3SP03T				591		9,3
3SP05S	8		323	664	2,7	11
3SP05T				669		10,5
3SP07S	11		386	747	3,3	12,5
3SP07T				752		12,1
3SP11S	16		491	883	4,3	14,8
3SP11T				893		14,5
3SP15S	22		617	1049	5,5	17,9
3SP15T				1059		17,4
3SP22S	32		827	1372	7,5	24,6
3SP22T				1347		24,2
3SP30T	44		1079	1674	9,9	29,7
3SP40T	59		1394	2038	12,9	35,0

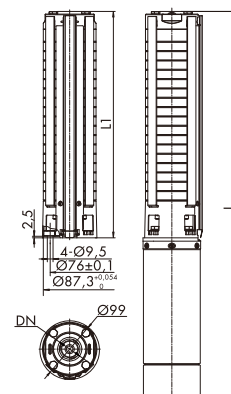

5SP SERIES

OPERATING CHARACTERISTICS AT 50 Hz

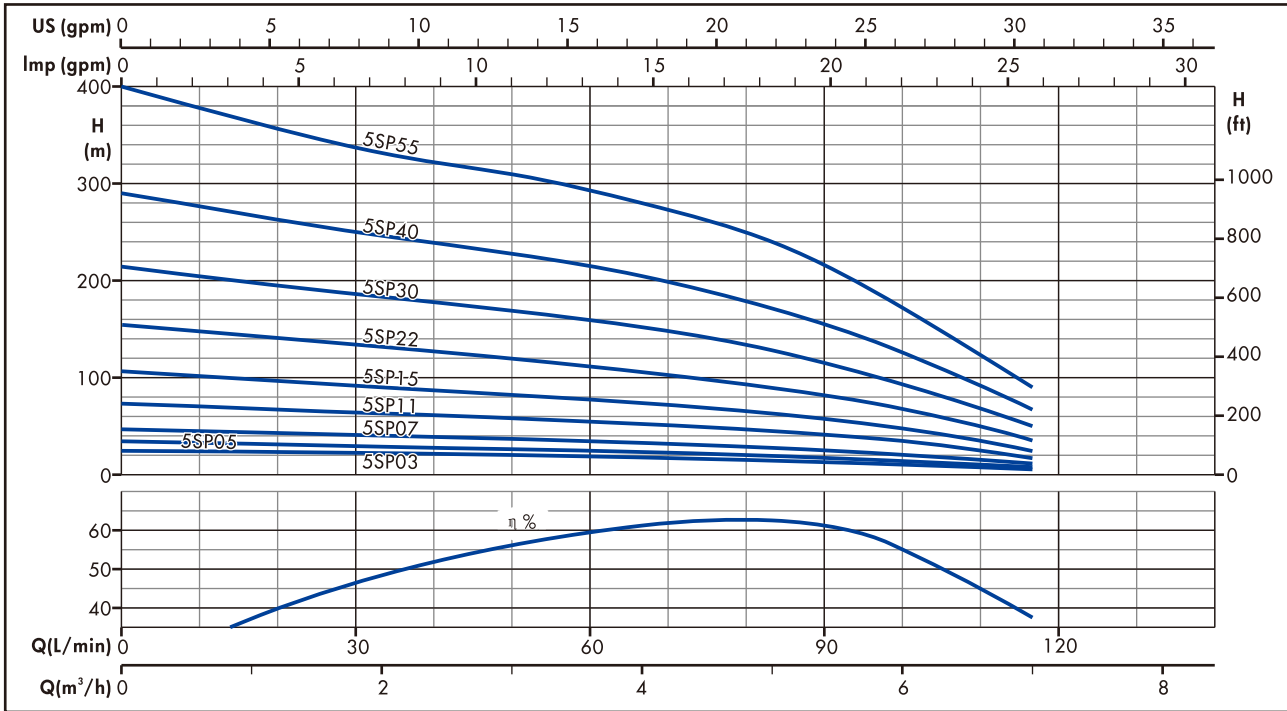

OPERATING CHARACTERISTICS AT 50 Hz

PUMP TYPE	N.OF STAGES	kW	Hp	Q=DELIVERY							
				L/min 0	33	50	67	83	100	117	
				m³/h 0	2	3	4	5	6	7	
				H=TOTAL HEAD METERS COLUMN OF WATER							
5SP03S	4	0,37	0,5	25	23	20	19	16	12	6	
5SP03T											
5SP05S											
5SP05T	5	0,55	0,75	33	30	26	24	19	15	8	
5SP07S											
5SP07T	7	0,75	1,0	47	40	36	33	28	21	11	
5SP11S											
5SP11T	11	1,1	1,5	74	62	58	52	44	33	17	
5SP15S											
5SP15T	16	1,5	2,0	108	90	83	76	66	48	25	
5SP22S											
5SP22T	23	2,2	3,0	155	132	121	109	92	68	35	
5SP30T											
5SP40T	32	3,0	4,0	217	182	170	152	128	94	49	
5SP40T	43	4,0	5,5	290	243	228	204	174	128	66	
5SP55T	59	5,5	7,5	400	333	312	281	240	176	91	

DIMENSIONS AND WEIGHTS AT 50 Hz

PUMP TYPE	N.OF STAGE	DN	L1 mm	L mm	PUMP WEIGHT Kg	ELECTRIC PUMP WEIGHT Kg
5SP03S	4	Rp1"1/4	239	565	1,9	9,6
5SP03T				570		9,1
5SP05S				601		10,5
5SP05T	5		260	606	2,2	10
5SP07S				663		11,8
5SP07T	7		302	668	2,6	11,4
5SP11S				778		13,9
5SP11T	11		386	788	3,4	13,6
5SP15S				923		16,9
5SP15T	16		491	933	4,5	16,4
5SP22S				1183		23,1
5SP22T	23		638	1158	5,9	22,6
5SP30T		1422		27,6		
5SP40T	32	827	1422	7,8	27,6	
5SP40T	43	1058	1702	10,1	32,3	
5SP55T	59	1394	2158	13,5	41,2	

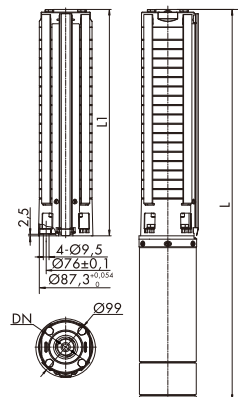

8SP SERIES

OPERATING CHARACTERISTICS AT 50 Hz

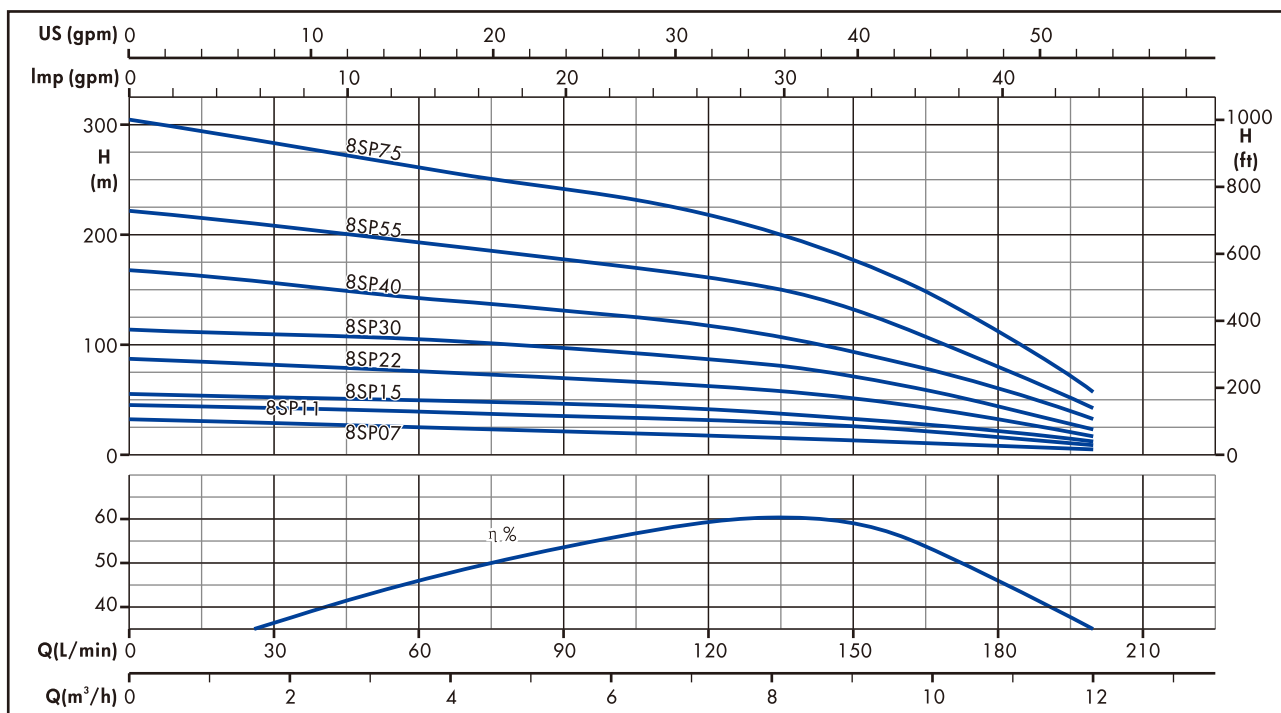

OPERATING CHARACTERISTICS AT 50 Hz

PUMP TYPE	N.OF STAGES	kW	Hp	Q=DELIVERY						
				L/min 0	33	67	100	133	167	200
				m³/h 0	2	4	6	8	10	12
				H=TOTAL HEAD METERS COLUMN OF WATER						
8SP07S	4	0,75	1,0	26	26	21	20	17	12	5
8SP07T										
8SP11S	7	1,1	1,5	44	43	38	34	30	21	8
8SP11T										
8SP15S	9	1,5	2,0	57	54	48	44	39	27	11
8SP15T										
8SP22S	14	2,2	3,0	89	83	75	68	59	42	17
8SP22T										
8SP30T	19	3	4,0	120	113	102	94	84	57	23
8SP40T	26	4	5,5	165	155	140	128	114	78	31
8SP55T	35	5,5	7,5	222	208	188	172	155	105	42
8SP75T	48	7,5	10	305	280	258	235	210	145	58

DIMENSIONS AND WEIGHTS AT 50 Hz

PUMP TYPE	N.OF STAGE	DN	L1 mm	L mm	PUMP WEIGHT Kg	ELECTRIC PUMP WEIGHT Kg
8SP07S	4	Rp2"	261	622	2,2	11,4
8SP07T				627		11,0
8SP11S	7		343	735	3	13,5
8SP11T				745		13,2
8SP15S	9		398	830	3,5	16,0
8SP15T				840		15,5
8SP22S	14		536	1080	4,9	22,0
8SP22T				1055		21,6
8SP30T	19		673	1268	6,2	26,0
8SP40T	26		866	1509	8,1	30,2
8SP55T	35		1113	1877	10,5	38,2
8SP75T	48		1471	2349	14,0	47,4

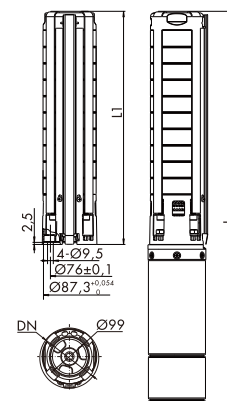

14SP SERIES

OPERATING CHARACTERISTICS AT 50 Hz

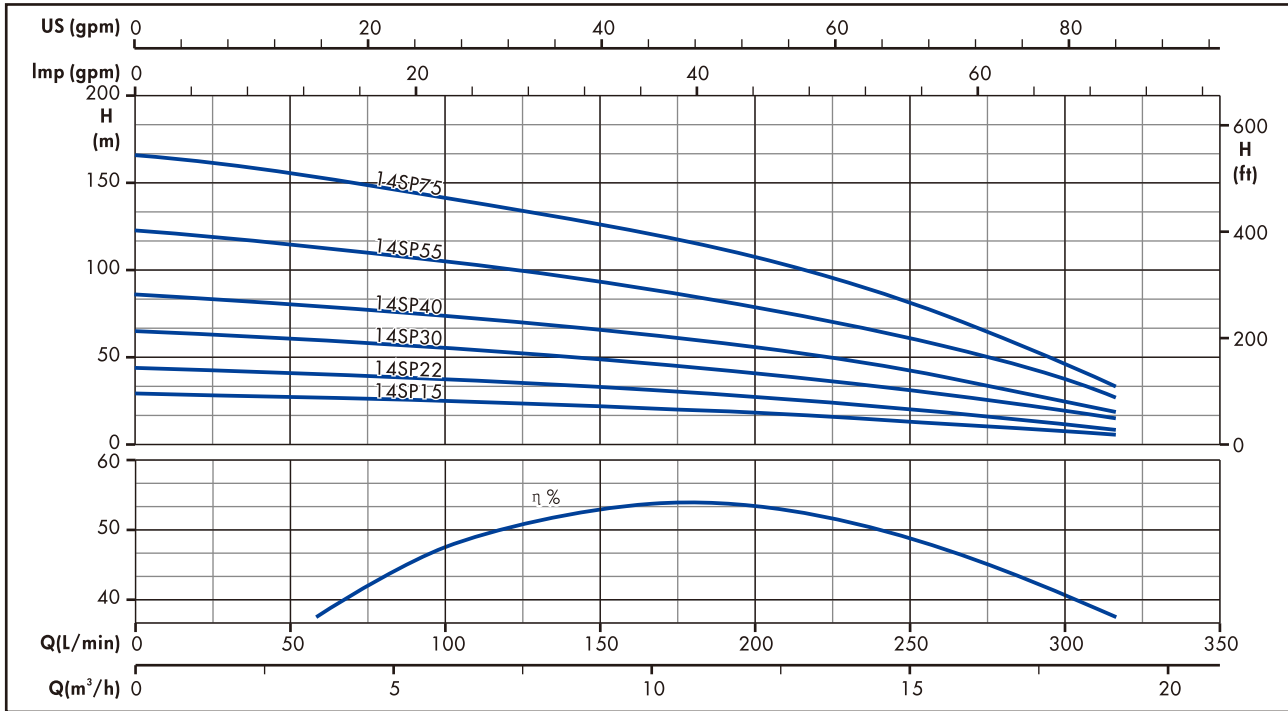

OPERATING CHARACTERISTICS AT 50 Hz

PUMP TYPE	N.OF STAGES	kW	Hp	Q = DELIVERY							
				L/min 0	100	133	167	200	233	267	317
				m³/h 0	6	8	10	12	14	16	19
				H = TOTAL HEAD METERS COLUMN OF WATER							
14SP15S	4	1,5	2,0	29	25	23	21	19	16	12	6
14SP15T											
14SP22S	6	2,2	3,0	43	37	35	32	28	24	18	9
14SP22T											
14SP30T	9	3,0	4,0	65	55	52	48	42	36	28	14
14SP40T	12	4,0	5,5	86	74	68	63	57	47	37	19
14SP55T	17	5,5	7,5	122	104	97	90	80	68	53	27
14SP75T	23	7,5	10	166	141	132	120	108	91	72	36

DIMENSIONS AND WEIGHTS AT 50 Hz

PUMP TUPE	N.OF STAGE	DN	L1 mm	L mm	PUMP WEIGHT Kg	ELECTRIC PUMP WEIGHT Kg
14SP15S	4	Rp2"	312	744	3,1	15,5
14SP15T				754		15
14SP22S	6		396	940	4	21,1
14SP22T				915		20,7
14SP30T	9		522	1116	5,4	25,2
14SP40T	12		648	1291	6,7	28,8
14SP55T	17		858	1621	9,2	36,9
14SP75T	23		1110	1988	12	45,4

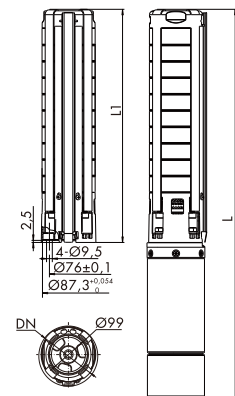



NEW JET S.R.L. UNIPERSONALE

TEL. +39 0522/736052

FAX +39 0522/736526

SEDE LEGALE: Via Fabio Filzi,45-59100 (PO) Italy

SEDE OPERATIVA: Via della Tecnica n.5-42015 Prato di Correggio (RE) Italy

P.iva/Cod.Fisc 02287380972

N° REA PO-520497

Capitale sociale € 50.000,00 i.v.

E-MAIL: newjetsrl@gmail.com

www.ircempump.com